

(19) World Intellectual Property Organization
International Bureau



(43) International Publication Date
11 July 2002 (11.07.2002)

PCT

(10) International Publication Number
WO 02/053867 A2

BEST AVAILABLE COPY

- (51) International Patent Classification: E21B
- (21) International Application Number: PCT/US02/00093
- (22) International Filing Date: 2 January 2002 (02.01.2002)
- (25) Filing Language: English
- (26) Publication Language: English
- (30) Priority Data:
60/259,486 3 January 2001 (03.01.2001) US
- (71) Applicant (for all designated States except US): ENVEN-
TURE GLOBAL TECHNOLOGY [US/US]; 16200 A
Park Row, Houston, TX 77084 (US).
- (72) Inventors; and
- (75) Inventors/Applicants (for US only): COOK, Robert.

- Lance [US/US]; 934 Caswell Court, Katy, TX 77450 (US).
RING, Lev [RU/US]; 14126 Heatherhill Place, Houston,
TX 77077 (US). ZWALD, Ed [US/US]; Memorial Drive
#110, Houston, TX 77024 (US). FILLIPOV, Andrei
[US/US]; 2606 Hidden Shore Drive, Katy, TX 77450 (US).
WADELL, Kevin [US/US]; 11007 Sprucedale Court,
Houston, TX 77070 (US).
- (74) Agents: MATTINGLY, Todd et al.; Haynes and Boone,
LLP, 1000 Louisiana, Suite 4300, Houston, TX 77002-
5012 (US).
- (81) Designated States (national): AE, AG, AL, AM, AT, AU,
AZ, BA, BB, BG, BR, BY, BZ, CA, CH, CN, CO, CR, CU,
CZ, DE, DK, DM, DZ, EE, ES, FI, GB, GD, GE, GH, GM,
HR, HU, ID, IL, IN, IS, JP, KE, KG, KP, KR, KZ, LC, LK,
LR, LS, LI, LU, LV, MA, MD, MG, MK, MN, MW, MX,
MZ, NO, NZ, OM, PH, PL, PT, RO, RU, SD, SE, SG, SI,
SK, SL, TJ, TM, TN, TR, TT, TZ, UA, UG, US, UZ, VN,
YU, ZA, ZM, ZW.

[Continued on next page]

(54) Title: MONO-DIAMETER WELLBORE CASING

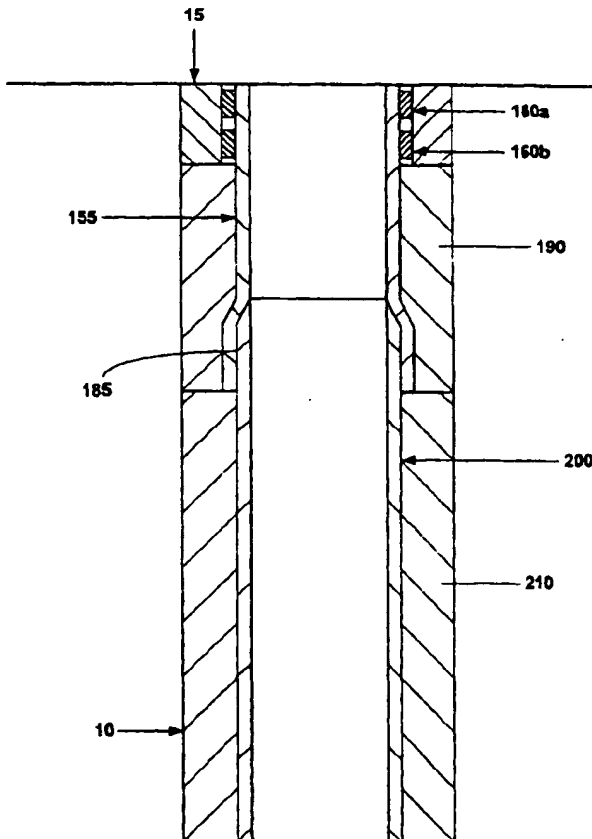

(57) Abstract: A mono-diameter wellbore casing. The mono-diameter wellbore casing is formed by plastically deforming and radially expanding a first tubular member within a wellbore. A second tubular member is then plastically deformed and radially expanded in overlapping relation to the first tubular member. The second tubular member and the overlapping portion of the first tubular member are then radially expanded again.

WO 02/053867 A2





(84) Designated States (regional): ARIPO patent (GH, GM, KE, LS, MW, MZ, SD, SL, SZ, TZ, UG, ZM, ZW), Eurasian patent (AM, AZ, BY, KG, KZ, MD, RU, TJ, TM), European patent (AT, BE, CH, CY, DE, DK, ES, FI, FR, GB, GR, IE, IT, LU, MC, NL, PT, SE, TR), OAPI patent (BF, BJ, CF, CG, CI, CM, GA, GN, GQ, GW, ML, MR, NF, SN, TD, TG).

Published:

— without international search report and to be republished upon receipt of that report

For two-letter codes and other abbreviations, refer to the "Guidance Notes on Codes and Abbreviations" appearing at the beginning of each regular issue of the PCT Gazette.

MONO-DIAMETER WELLBORE CASING

Cross Reference To Related Applications

This application is related to the following co-pending applications: (1) U.S. patent application serial no. 09/454,139, attorney docket no. 25791.03.02, filed on 12/3/1999, (2) U.S. patent application serial no. 09/510,913, attorney docket no. 25791.7.02, filed on 2/23/2000, (3) U.S. patent application serial no. 09/502,350, attorney docket no. 25791.8.02, filed on 2/10/2000, (4) U.S. patent application serial no. 09/440,338, attorney docket no. 25791.9.02, filed on 11/15/1999, (5) U.S. patent application serial no. 09/523,460, attorney docket no. 25791.11.02, filed on 3/10/2000, (6) U.S. patent application serial no. 09/512,895, attorney docket no. 25791.12.02, filed on 2/24/2000, (7) U.S. patent application serial no. 09/511,941, attorney docket no. 25791.16.02, filed on 2/24/2000, (8) U.S. patent application serial no. 09/588,946, attorney docket no. 25791.17.02, filed on 6/7/2000, (9) U.S. patent application serial no. 09/559,122, attorney docket no. 25791.23.02, filed on 4/26/2000, (10) PCT patent application serial no. PCT/US00/18635, attorney docket no. 25791.25.02, filed on 7/9/2000, (11) U.S. provisional patent application serial no. 60/162,671, attorney docket no. 25791.27, filed on 11/1/1999, (12) U.S. provisional patent application serial no. 60/154,047, attorney docket no. 25791.29, filed on 9/16/1999, (13) U.S. provisional patent application serial no. 60/159,082, attorney docket no. 25791.34, filed on 10/12/1999, (14) U.S. provisional patent application serial no. 60/159,039, attorney docket no. 25791.36, filed on 10/12/1999, (15) U.S. provisional patent application serial no. 60/159,033, attorney docket no. 25791.37, filed on 10/12/1999, (16) U.S. provisional patent application serial no. 60/212,359, attorney docket no. 25791.38, filed on 6/19/2000, (17) U.S. provisional patent application serial no. 60/165,228, attorney docket no. 25791.39, filed on 11/12/1999, (18) U.S. provisional patent application serial no. 60/221,443, attorney docket no. 25791.45, filed on 7/28/2000, (19) U.S. provisional patent application serial no. 60/221,645, attorney docket no. 25791.46, filed on 7/28/2000, (20) U.S. provisional patent application serial no. 60/233,638, attorney docket no. 25791.47, filed on 9/18/2000, and (21) U.S. provisional patent application serial no. 60/237,334, filed on October 2, 2000. Applicants incorporate by reference the disclosures of these applications.

30

Background of the Invention

This invention relates generally to wellbore casings, and in particular to wellbore casings that are formed using expandable tubing.

Conventionally, when a wellbore is created, a number of casings are installed in the borehole to prevent collapse of the borehole wall and to prevent undesired outflow of drilling fluid into the formation or inflow of fluid from the formation into the borehole. The borehole is drilled in intervals whereby a casing which is to be installed in a lower borehole interval is lowered through a previously installed casing of an upper borehole interval. As a consequence of this procedure the casing of the lower interval is of smaller diameter than the casing of the upper interval. Thus, the casings are in a nested arrangement with casing diameters decreasing in downward direction. Cement annuli are provided between the outer surfaces of the casings and the borehole wall to seal the casings from the borehole wall. As a consequence of this nested arrangement a relatively large borehole diameter is required at the upper part of the wellbore. Such a large borehole diameter involves increased costs due to heavy casing handling equipment, large drill bits and increased volumes of drilling fluid and drill cuttings. Moreover, increased drilling rig time is involved due to required cement pumping, cement hardening, required equipment changes due to large variations in hole diameters drilled in the course of the well, and the large volume of cuttings drilled and removed.

The present invention is directed to overcoming one or more of the limitations of the existing procedures for forming wellbores.

Summary of the Invention

According to one aspect of the invention, an apparatus for plastically deforming and radially expanding a tubular member is provided that includes means for plastically deforming and radially expanding a first portion of the tubular member to a first outside diameter, and means for plastically deforming and radially expanding a second portion of the tubular member to a second outside diameter.

According to another aspect of the present invention, an apparatus for plastically deforming and radially expanding a tubular member is provided that includes a tubular support member including a first fluid passage, an expansion cone coupled to the tubular support member having a second fluid passage fluidically coupled to the first fluid passage and an outer conical surface, a removable annular conical sleeve coupled to the outer conical surface of the expansion cone, an annular expansion cone launcher coupled to the conical sleeve and a lower portion of the tubular member, and a shoe having a valveable passage coupled to an end of the expansion cone launcher.

According to another aspect of the present invention, a method of plastically deforming and radially expanding a tubular member is provided that includes plastically deforming and radially expanding a portion of the tubular member to a first outside diameter, and plastically deforming and radially expanding another portion of the tubular member to a second outside diameter.

According to another aspect of the present invention, a method of coupling a first tubular member to a second tubular member is provided that includes plastically deforming and radially expanding a first portion of the first tubular member to a first outside diameter, plastically deforming and radially expanding another portion of the first tubular member to a second outside diameter, positioning the second tubular member inside the first tubular member in overlapping relation to the first portion of the first tubular member, plastically deforming and radially expanding the second tubular member to a third outside diameter, and plastically deforming and radially expanding the second tubular member to a fourth outside diameter. The inside diameters of the first and second tubular members after the plastic deformations and radial expansions are substantially equal.

According to another aspect of the present invention, an apparatus for coupling a first tubular member to a second tubular member is provided that includes means for plastically deforming and radially expanding a first portion of the first tubular member to a first outside diameter, means for plastically deforming and radially expanding another portion of the first tubular member to a second outside diameter, means for positioning the second tubular member inside the first tubular member in overlapping relation to the first portion of the first tubular member, means for plastically deforming and radially expanding the second tubular member to a third outside diameter, and means for plastically deforming and radially expanding the second tubular member to a fourth outside diameter. The inside diameters of the first and second tubular members after the plastic deformations and radial expansions are substantially equal.

According to another aspect of the present invention, an apparatus for forming a wellbore casing within a wellbore is provided that includes means for supporting a tubular member within the wellbore, means for plastically deforming and radially expanding a first portion of the tubular member to a first outside diameter, and means for plastically deforming and radially expanding a second portion of the tubular member to a second outside diameter.

According to another aspect of the present invention, an apparatus for forming a wellbore casing within a wellbore is provided that includes a tubular support member including a first fluid passage, an expansion cone coupled to the tubular support member having a second fluid passage fluidically coupled to the first fluid passage and an outer
5 conical surface, a removable annular conical sleeve coupled to the outer conical surface of the expansion cone, an annular expansion cone launcher coupled to the conical sleeve and a lower portion of the tubular member, and a shoe having a valveable passage coupled to an end of the expansion cone launcher.

According to another aspect of the present invention, a method of forming a
10 wellbore casing within a wellbore is provided that includes supporting a tubular member within a wellbore, plastically deforming and radially expanding a portion of the tubular member to a first outside diameter, and plastically deforming and radially expanding another portion of the tubular member to a second outside diameter.

According to another aspect of the present invention, a method of forming a mono-
15 diameter wellbore casing within a wellbore is provided that includes supporting a first tubular member within the wellbore, plastically deforming and radially expanding a first portion of the first tubular member to a first outside diameter, plastically deforming and radially expanding another portion of the first tubular member to a second outside diameter, positioning the second tubular member inside the first tubular member in
20 overlapping relation to the first portion of the first tubular member, plastically deforming and radially expanding the second tubular member to a third outside diameter, and plastically deforming and radially expanding the second tubular member to a fourth outside diameter. The inside diameters of the first and second tubular members after the plastic deformations and radial expansions are substantially equal.

25 According to another aspect of the present invention, an apparatus for coupling a first tubular member to a second tubular member is provided that includes means for plastically deforming and radially expanding a first portion of the first tubular member to a first outside diameter, means for plastically deforming and radially expanding another portion of the first tubular member to a second outside diameter, means for positioning the
30 second tubular member inside the first tubular member in overlapping relation to the first portion of the first tubular member, means for plastically deforming and radially expanding the second tubular member to a third outside diameter, and

means for plastically deforming and radially expanding the second tubular member to a fourth outside diameter. The inside diameters of the first and second tubular members after the plastic deformations and radial expansions are substantially equal.

5 According to another aspect of the present invention, an apparatus for plastically deforming and radially expanding a tubular member is provided that includes means for providing a lipped portion in a portion of the tubular member, and means for plastically deforming and radially expanding another portion of the tubular member.

10 According to another aspect of the present invention, an apparatus for plastically deforming and radially expanding a tubular member is provided that includes a tubular support member including a first fluid passage, an expansion cone coupled to the tubular support member having a second fluid passage fluidically coupled to the first fluid passage and an outer conical surface, an annular expansion cone launcher including: a first annular portion coupled to a lower portion of the tubular member, a second annular portion coupled to the first annular portion that mates with the outer conical surface of the
15 expansion cone, a third annular portion coupled to the second annular portion having a first outside diameter, and a fourth annular portion coupled to the third annular portion having a second outside diameter, wherein the second outside diameter is less than the first outside diameter, and a shoe having a valveable passage coupled to fourth annular portion of the expansion cone launcher.

20 According to another aspect of the present invention, a method of plastically deforming and radially expanding a tubular member is provided that includes providing a lipped portion in a portion of the tubular member, and plastically deforming and radially expanding another portion of the tubular member.

25 According to another aspect of the present invention, a method of coupling a first tubular member to a second tubular member is provided that includes providing a lipped portion in a portion of the first tubular member, plastically deforming and radially expanding another portion of the first tubular member, positioning the second tubular member inside the first tubular member in overlapping relation to the lipped portion of the first tubular member, and plastically deforming and radially expanding the second tubular
30 member. The inside diameters of the first and second tubular members after the plastic deformations and radial expansions are substantially equal.

According to another aspect of the present invention, an apparatus for coupling a first tubular member to a second tubular member is provided that includes means for

providing a lipped in the first tubular member, means for plastically deforming and radially expanding another portion of the first tubular member, means for positioning the second tubular member inside the first tubular member in overlapping relation to the lipped portion of the first tubular member, and means for plastically deforming and radially expanding the second tubular member. The inside diameters of the first and second tubular members after the plastic deformations and radial expansions are substantially equal.

According to another aspect of the present invention, an apparatus for forming a wellbore casing within a wellbore is provided that includes means for supporting a tubular member within the wellbore, means for providing a lipped portion in the tubular member, and means for plastically deforming and radially expanding another portion of the tubular member to a second outside diameter.

According to another aspect of the present invention, an apparatus for forming a wellbore casing within a wellbore is provided that includes a tubular support member including a first fluid passage, an expansion cone coupled to the tubular support member having a second fluid passage fluidically coupled to the first fluid passage and an outer conical surface, an annular expansion cone launcher including: a first annular portion coupled to a lower portion of the tubular member, a second annular portion coupled to the first annular portion that mates with the outer conical surface of the expansion cone, a third annular portion coupled to the second annular portion having a first outside diameter, and a fourth annular portion coupled to the third annular portion having a second outside diameter, wherein the second outside diameter is less than the first outside diameter, and a shoe having a valveable passage coupled to fourth annular portion of the expansion cone launcher.

According to another aspect of the present invention, a method of forming a wellbore casing in a wellbore is provided that includes supporting a tubular member within the wellbore, providing a lipped portion in a portion of the tubular member, and plastically deforming and radially expanding another portion of the tubular member.

According to another aspect of the present invention, a method of forming a mono-diameter wellbore casing within a wellbore is provided that includes supporting a first tubular member within the wellbore, providing a lipped portion in a portion of the first tubular member, plastically deforming and radially expanding another portion of the first tubular member, positioning the second tubular member inside the first tubular member in

overlapping relation to the lipped portion of the first tubular member, and plastically deforming and radially expanding the second tubular member. The inside diameters of the first and second tubular members after the plastic deformations and radial expansions are substantially equal.

5 According to another aspect of the present invention, an apparatus for forming a mono-diameter wellbore casing within a wellbore is provided that includes means for providing a lipped in the first tubular member, means for plastically deforming and radially expanding another portion of the first tubular member, means for positioning the second tubular member inside the first tubular member in overlapping relation to the
10 lipped portion of the first tubular member, and means for plastically deforming and radially expanding the second tubular member. The inside diameters of the first and second tubular members after the plastic deformations and radial expansions are substantially equal.

 According to another aspect of the present invention, an apparatus for plastically
15 deforming and radially expanding a tubular member is provided that includes means for plastically deforming and radially expanding a first end of the tubular member, and means for plastically deforming and radially expanding a second end of the tubular member.

 According to another aspect of the present invention, an apparatus for plastically
20 deforming and radially expanding a tubular member is provided that includes a tubular support member including a first passage, an expansion cone coupled to the tubular support having a second passage fluidically coupled to the first passage and an outer conical surface, an annular expansion cone launcher movably coupled to outer conical surface of the expansion cone, an expandable tubular member coupled to an end of the annular expansion cone launcher, a shoe coupled to another end of the annular expansion cone
25 launcher having a valveable fluid passage, and another annular expansion cone movably coupled to the tubular support member. The annular expansion cones are positioned in opposite orientations.

 According to another aspect of the present invention, a method of plastically
30 deforming and radially expanding a tubular member is provided that includes plastically deforming and radially expanding a first end of the tubular member, and plastically deforming and radially expanding a second end of the tubular member.

 According to another aspect of the present invention, a method of coupling a first tubular member to a second tubular member is provided that includes positioning the

second tubular member inside the first tubular member in an overlapping relationship, plastically deforming and radially expanding the end of the second tubular member that overlaps with the first tubular member, and plastically deforming and radially expanding the remaining portion of the second tubular member.

5 According to another aspect of the present invention, an apparatus for coupling a first tubular member to a second tubular member is provided that includes means for positioning the second tubular member inside the first tubular member in an overlapping relationship, means for plastically deforming and radially expanding the end of the second tubular member that overlaps with the first tubular member, and means for plastically
10 deforming and radially expanding the remaining portion of the second tubular member.

 According to another aspect of the present invention, an apparatus for forming a wellbore casing within a wellbore is provided that includes means for supporting a tubular member within the wellbore, means for plastically deforming and radially expanding a first end of the tubular member, and means for plastically deforming and radially expanding a
15 second end of the tubular member.

 According to another aspect of the present invention, an apparatus for forming a wellbore casing within a wellbore is provided that includes a tubular support member including a first passage, an expansion cone coupled to the tubular support having a second passage fluidically coupled to the first passage and an outer conical surface, an
20 annular expansion cone launcher movably coupled to outer conical surface of the expansion cone, an expandable tubular member coupled to an end of the annular expansion cone launcher, a shoe coupled to another end of the annular expansion cone launcher having a valveable fluid passage, and another annular expansion cone movably coupled to the tubular support member. The annular expansion cones are positioned in
25 opposite orientations.

 According to another aspect of the present invention, a method of forming a wellbore casing within a wellbore is provided that includes plastically deforming and radially expanding a first end of the tubular member, and plastically deforming and radially expanding a second end of the tubular member.

30 According to another aspect of the present invention, a method of forming a wellbore casing within a wellbore is provided that includes plastically deforming and radially expanding a first tubular member within the wellbore, positioning a second tubular member inside the first tubular member in an overlapping relationship, plastically

deforming and radially expanding the end of the second tubular member that overlaps with the first tubular member, and plastically deforming and radially expanding the remaining portion of the second tubular member.

According to another aspect of the present invention, an apparatus for forming a wellbore casing within a wellbore is provided that includes means for plastically
5 deforming and radially expanding a first tubular member within the wellbore, means for positioning the second tubular member inside the first tubular member in an overlapping relationship, means for plastically deforming and radially expanding the end of the second tubular member that overlaps with the first tubular member, and means for plastically
10 deforming and radially expanding the remaining portion of the second tubular member.

According to another aspect of the present invention, an apparatus for bridging an axial gap between opposing pairs of wellbore casing within a wellbore is provided that includes means for supporting a tubular member in overlapping relation to the opposing ends of the wellbore casings, means for plastically deforming and radially expanding the
15 tubular member, and means for plastically deforming and radially expanding the tubular member and the opposing ends of the wellbore casings.

According to another aspect of the present invention, a method of bridging an axial gap between opposing pairs of wellbore casing within a wellbore is provided that includes
20 supporting a tubular member in overlapping relation to the opposing ends of the wellbore casings, plastically deforming and radially expanding the tubular member, and plastically deforming and radially expanding the tubular member and the opposing ends of the wellbore casings.

According to another aspect of the present invention, a method of forming a
25 structure having desired strength characteristics is provided that includes providing a first tubular member, and plastically deforming and radially expanding additional tubular members onto the interior surface of the first tubular member until the desired strength characteristics are achieved.

According to another aspect of the present invention, a method of forming a
30 wellbore casing within a wellbore having desired strength characteristics is provided that includes plastically deforming and radially expanding a first tubular member within the wellbore, and plastically deforming and radially expanding additional tubular members

onto the interior surface of the first tubular member until the desired strength characteristics are achieved.

According to another aspect of the present invention, a method of coupling a first tubular member to a second tubular member, the first tubular member having an original
5 outside diameter OD_0 and an original wall thickness t_0 , is provided that includes plastically deforming and radially expanding a first portion of the first tubular member to a first outside diameter, plastically deforming and radially expanding another portion of the first tubular member to a second outside diameter, positioning the second tubular member
10 inside the first tubular member in overlapping relation to the first portion of the first tubular member, plastically deforming and radially expanding the second tubular member to a third outside diameter, and plastically deforming and radially expanding the second tubular member to a fourth outside diameter. The inside diameters of the first and second tubular members after the plastic deformations and radial expansions are substantially equal, and the ratio of the original outside diameter OD_0 of the first tubular member to the
15 original wall thickness t_0 of the first tubular member is greater than or equal to 16.

According to another aspect of the present invention, a method of forming a mono-diameter wellbore casing is provided that includes positioning a first tubular member within a wellbore, the first tubular member having an original outside diameter OD_0 and an original wall thickness t_0 , plastically deforming and radially expanding a first portion of
20 the first tubular member to a first outside diameter, plastically deforming and radially expanding another portion of the first tubular member to a second outside diameter, positioning the second tubular member inside the first tubular member in overlapping relation to the first portion of the first tubular member, plastically deforming and radially expanding the second tubular member to a third outside diameter, and plastically
25 deforming and radially expanding the second tubular member to a fourth outside diameter. The inside diameters of the first and second tubular members after the plastic deformations and radial expansions are substantially equal, and the ratio of the original outside diameter OD_0 of the first tubular member to the original wall thickness t_0 of the first tubular member is greater than or equal to 16.

30 According to another aspect of the present invention, an apparatus is provided that includes a plastically deformed and radially expanded tubular member having a first portion having a first outside diameter and a remaining portion having a second outside

diameter. The ratio of the original outside diameter OD_0 of the first tubular member to the original wall thickness t_0 of the first tubular member is greater than or equal to 16.

According to another aspect of the present invention, an apparatus is provided that includes a plastically deformed and radially expanded first tubular member having a first
5 portion having a first outside diameter and a remaining portion having a second outside diameter, and a plastically deformed and radially expanded second tubular member coupled to the first portion of the first tubular member. The ratio of the original outside diameter OD_0 of the first tubular member to the original wall thickness t_0 of the first tubular member is greater than or equal to 16.

10 According to another aspect of the present invention, a wellbore casing formed in a wellbore is provided that includes a plastically deformed and radially expanded first tubular member having a first portion having a first outside diameter and a remaining portion having a second outside diameter, and a plastically deformed and radially expanded second tubular member coupled to the first portion of the first tubular member.
15 The ratio of the original outside diameter OD_0 of the first tubular member to the original wall thickness t_0 of the first tubular member is greater than or equal to 16.

According to another aspect of the present invention, an apparatus is provided that includes a plastically deformed and radially expanded tubular member. The ratio of the original outside diameter OD_0 of the tubular member to the original wall thickness t_0 of the tubular member is greater than or equal to 16.
20

Brief Description of the Drawings

Fig. 1a is a cross sectional illustration of a wellbore including a preexisting wellbore casing.

Fig. 1b is a cross-sectional illustration of the placement of an embodiment of an
25 apparatus for radially expanding a tubular member into the wellbore of Fig. 1a.

Fig. 1c is a cross-sectional illustration of the injection of fluidic materials through the apparatus of Fig. 1b.

Fig. 1d is a cross-sectional illustration of the injection of hardenable fluidic sealing materials through the apparatus of Fig. 1c.

30 Fig. 1e is a cross-sectional illustration of the pressurization of the region below the expansion cone of the apparatus of Fig. 1d.

Fig. 1f is a cross-sectional illustration of the continued pressurization of the region below the expansion cone of the apparatus of Fig. 1e.

Fig. 1g is a cross-sectional illustration of the continued pressurization of the region below the expansion cone of the apparatus of Fig. 1f following the removal of the over-expansion sleeve.

Fig. 1h is a cross-sectional illustration of the completion of the radial expansion of the expandable tubular member of the apparatus of Fig. 1g.

Fig. 1i is a cross-sectional illustration of the drilling out of a new section of the wellbore below the apparatus of Fig. 1h.

Fig. 1j is a cross-sectional illustration of the radial expansion of another expandable tubular member that overlaps with the apparatus of Fig. 1i.

Fig. 1k is a cross-sectional illustration of the secondary radial expansion of the other expandable tubular member of the apparatus of Fig. 1l.

Fig. 1l is a cross-sectional illustration of the completion of the secondary radial expansion of the other expandable tubular member of Fig. 1k to form a mono-diameter wellbore casing.

Fig. 2a is a cross sectional illustration of a wellbore including a preexisting wellbore casing.

Fig. 2b is a cross-sectional illustration of the placement of an embodiment of an apparatus for radially expanding a tubular member into the wellbore of Fig. 2a.

Fig. 2c is a cross-sectional illustration of the injection of fluidic materials through the apparatus of Fig. 2b.

Fig. 2d is a cross-sectional illustration of the injection of hardenable fluidic sealing materials through the apparatus of Fig. 2c.

Fig. 2e is a cross-sectional illustration of the pressurization of the region below the expansion cone of the apparatus of Fig. 2d.

Fig. 2f is a cross-sectional illustration of the continued pressurization of the region below the expansion cone of the apparatus of Fig. 2e.

Fig. 2g is a cross-sectional illustration of the completion of the radial expansion of the expandable tubular member of the apparatus of Fig. 2f.

Fig. 2h is a cross-sectional illustration of the drilling out of a new section of the wellbore below the apparatus of Fig. 2g.

Fig. 2i is a cross-sectional illustration of the radial expansion of another expandable tubular member that overlaps with the apparatus of Fig. 2h.

Fig. 2j is a cross-sectional illustration of the secondary radial expansion of the other expandable tubular member of the apparatus of Fig. 2i.

Fig. 2k is a cross-sectional illustration of the completion of the secondary radial expansion of the other expandable tubular member of Fig. 2j to form a mono-diameter
5 wellbore casing.

Fig. 3 is a cross-sectional illustration of the apparatus of Fig. 2b illustrating the design and construction of the over-expansion insert.

Fig. 3a is a cross-sectional illustration of an alternative embodiment of the over-expansion insert of Fig. 3.

10 Fig. 4 is a cross-sectional illustration of an alternative embodiment of the apparatus of Fig. 2b including a resilient hook for retrieving the over-expansion insert.

Fig. 5a is a cross-sectional illustration of a wellbore including a preexisting wellbore casing.

15 Fig. 5b is a cross-sectional illustration of the formation of a new section of wellbore casing in the wellbore of Fig. 5a.

Fig. 5c is a fragmentary cross-sectional illustration of the placement of an inflatable bladder into the new section of the wellbore casing of Fig. 5b.

Fig. 5d is a fragmentary cross-sectional illustration of the inflation of the inflatable bladder of Fig. 5c.

20 Fig. 5e is a cross-sectional illustration of the new section of wellbore casing of Fig. 5d after over-expansion.

Fig. 5f is a cross-sectional illustration of the new section of wellbore casing of Fig. 5e after drilling out a new section of the wellbore.

25 Fig. 5g is a cross-sectional illustration of the formation of a mono-diameter wellbore casing that includes the new section of the wellbore casing and an additional section of wellbore casing.

Fig. 6a is a cross-sectional illustration of a wellbore including a preexisting wellbore casing.

30 Fig. 6b is a cross-sectional illustration of the formation of a new section of wellbore casing in the wellbore of Fig. 6a.

Fig. 6c is a fragmentary cross-sectional illustration of the placement of a roller radial expansion device into the new section of the wellbore casing of Fig. 6b.

Fig. 6d is a cross-sectional illustration of the new section of wellbore casing of Fig. 6c after over-expansion.

Fig. 6e is a cross-sectional illustration of the new section of wellbore casing of Fig. 6d after drilling out a new section of the wellbore.

5 Fig. 6f is a cross-sectional illustration of the formation of a mono-diameter wellbore casing that includes the new section of the wellbore casing and an additional section of wellbore casing.

Fig. 7a is a cross sectional illustration of a wellbore including a preexisting wellbore casing.

10 Fig. 7b is a cross-sectional illustration of the placement of an embodiment of an apparatus for radially expanding a tubular member into the wellbore of Fig. 7a.

Fig. 7c is a cross-sectional illustration of the injection of fluidic materials through the apparatus of Fig. 7b.

15 Fig. 7d is a cross-sectional illustration of the injection of hardenable fluidic sealing materials through the apparatus of Fig. 7c.

Fig. 7e is a cross-sectional illustration of the pressurization of the region below the expansion cone of the apparatus of Fig. 7d.

Fig. 7f is a cross-sectional illustration of the continued pressurization of the region below the expansion cone of the apparatus of Fig. 7e.

20 Fig. 7g is a cross-sectional illustration of the completion of the radial expansion of the expandable tubular member of the apparatus of Fig. 7f.

Fig. 7h is a cross-sectional illustration of the drilling out of a new section of the wellbore below the apparatus of Fig. 7g.

25 Fig. 7i is a cross-sectional illustration of the completion of the radial expansion of another expandable tubular member to form a mono-diameter wellbore casing.

Fig. 8a is cross-sectional illustration of an wellbore including a preexisting section of wellbore casing having a recessed portion.

Fig. 8b is a cross-sectional illustration of the placement of an apparatus for radially expanding a tubular member within the wellbore of Fig. 8a.

30 Fig. 8c is a cross-sectional illustration of the injection of fluidic materials through the apparatus of Fig. 8b.

Fig. 8d is a cross-sectional illustration of the injection of a hardenable fluidic sealing material through the apparatus of Fig. 8c.

Fig. 8e is cross-sectional illustration of the isolation of the region below the expansion cone and within the expansion cone launcher of the apparatus of Fig. 8d.

Fig. 8f is a cross-sectional illustration of the plastic deformation and radial expansion of the upper portion of the expandable tubular member of the apparatus of Fig. 8e.

Fig. 8g is a cross-sectional illustration of the removal of the upper expansion cone from the wellbore of fig. 8f.

Fig. 8h is a cross-sectional illustration of the continued pressurization of the region below the expansion cone of the apparatus of Fig. 8g to thereby plastically deform and radially expand the expansion cone launcher and expandable tubular member.

Fig. 8i is a cross-sectional illustration of the completion of the initial radial expansion process of the apparatus of Fig. 8h.

Fig. 8j is a cross-sectional illustration of the further radial expansion of the apparatus of Fig. 8i in order to form a mono-diameter wellbore casing.

Fig. 9a is a cross-sectional illustration of a wellbore including upper and lower preexisting wellbore casings that are separated by an axial gap.

Fig. 9b is a cross-sectional illustration of the coupling of a tubular member to the opposing ends of the wellbore casings of Fig. 9a.

Fig. 9c is a fragmentary cross-sectional illustration of the placement of a radial expansion device into the tubular member of Fig. 9b.

Fig. 9d is a fragmentary cross-sectional illustration of the actuation of the radial expansion device of Fig. 9c.

Fig. 9e is a cross-sectional of a mono-diameter wellbore casing generated by the actuation of the radial expansion device of Fig. 9d.

Fig. 10 is a cross-sectional illustration of a mono-diameter wellbore casing that includes a plurality of layers of radially expanded tubular members along at least a portion of the its length.

Fig. 11a is a cross-sectional illustration of a wellbore including a casing formed by plastically deforming and radially expanding a first tubular member.

Fig. 11b is a cross-sectional illustration of a wellbore including another casing coupled to the preexisting casing by plastically deforming and radially expanding a second tubular member.

Fig. 11c is a cross-sectional illustration of a mono-diameter wellbore casing formed by radially expanding the second tubular member a second time.

Detailed Description

Several embodiments of methods and apparatus for forming a mono-diameter wellbore casing are disclosed. In several alternative embodiments, the methods and apparatus may be used for form or repair mono-diameter wellbore casings, pipelines, or structural supports. Furthermore, while the present illustrative embodiments are described with reference to the formation of mono-diameter wellbore casings, the teachings of the present disclosure have general application to the formation or repair of wellbore casings, pipelines, and structural supports.

Referring initially to Fig. 1a, a wellbore 10 includes a preexisting wellbore casing 15. The wellbore 10 may be oriented in any orientation from the vertical to the horizontal. The preexisting wellbore casing 15 may be coupled to the upper portion of the wellbore 10 using any number of conventional methods. In a preferred embodiment, the wellbore casing 15 is coupled to the upper portion of the wellbore 10 using one or more of the methods and apparatus disclosed in one or more of the following: (1) U.S. patent application serial no. 09/454,139, attorney docket no. 25791.03.02, filed on 12/3/1999, (2) U.S. patent application serial no. 09/510,913, attorney docket no. 25791.7.02, filed on 2/23/2000, (3) U.S. patent application serial no. 09/502,350, attorney docket no. 25791.8.02, filed on 2/10/2000, (4) U.S. patent application serial no. 09/440,338, attorney docket no. 25791.9.02, filed on 11/15/1999, (5) U.S. patent application serial no. 09/523,460, attorney docket no. 25791.11.02, filed on 3/10/2000, (6) U.S. patent application serial no. 09/512,895, attorney docket no. 25791.12.02, filed on 2/24/2000, (7) U.S. patent application serial no. 09/511,941, attorney docket no. 25791.16.02, filed on 2/24/2000, (8) U.S. patent application serial no. 09/588,946, attorney docket no. 25791.17.02, filed on 6/7/2000, (9) U.S. patent application serial no. 09/559,122, attorney docket no. 25791.23.02, filed on 4/26/2000, (10) PCT patent application serial no. PCT/US00/18635, attorney docket no. 25791.25.02, filed on 7/9/2000, (11) U.S. provisional patent application serial no. 60/162,671, attorney docket no. 25791.27, filed on 11/1/1999, (12) U.S. provisional patent application serial no. 60/154,047, attorney docket no. 25791.29, filed on 9/16/1999, (13) U.S. provisional patent application serial no. 60/159,082, attorney docket no. 25791.34, filed on 10/12/1999, (14) U.S. provisional patent application serial no. 60/159,039, attorney docket no. 25791.36, filed on 10/12/1999, (15) U.S. provisional patent application serial no. 60/159,033, attorney docket no. 25791.37, filed on 10/12/1999, (16) U.S. provisional patent application serial no.

_____, attorney docket no. 25791.38, filed on 6/19/2000, (17) U.S. provisional patent application serial no. 60/165,228, attorney docket no. 25791.39, filed on 11/12/1999, (18) U.S. provisional patent application serial no. _____, attorney docket no. 25791.45, filed on 7/28/2000, (19) U.S. provisional patent application serial no. _____, attorney docket no. 25791.46, filed on 7/28/2000, and (20) U.S. provisional patent application serial no. _____, attorney docket no. 25791.47, filed on 9/18/2000, the disclosures of which are incorporated herein by reference. More generally, the preexisting wellbore casing 15 may be coupled to another preexisting wellbore casing and/or may include one or more concentrically positioned tubular members.

Referring to Fig. 1b, an apparatus 100 for radially expanding a tubular member may then be positioned within the wellbore 10. The apparatus 100 includes a tubular support member 105 defining a passage 110 for conveying fluidic materials. An expansion cone 115 defining a passage 120 and having an outer conical surface 125 for radially expanding tubular members is coupled to an end of the tubular support member 105. An annular conical over-expansion sleeve 130 mates with and is removably coupled to the outer conical surface 125 of the expansion cone 115. In several alternative embodiments, the over-expansion sleeve 130 is fabricated from frangible materials such as, for example, ceramic materials, in order to facilitate the removal of the over-expansion sleeve during operation of the apparatus 100. In this manner, the amount of radial expansion provided by the apparatus may be decreased following the removal of the over-expansion sleeve 130.

An expansion cone launcher 135 is movably coupled to and supported by the expansion cone 115 and the over-expansion sleeve 130. The expansion cone launcher 135 include an upper portion having an upper outer diameter, an intermediate portion that mates with the expansion cone 115 and the over-expansion sleeve 130, an a lower portion having a lower outer diameter. The lower outer diameter is greater than the upper outer diameter. A shoe 140 defining a valveable passage 145 is coupled to the lower portion of the expansion cone launcher 135. In a preferred embodiment, the valveable passage 145 may be controllably closed in order to fluidically isolate a region 150 below the expansion cone 115 and bounded by the lower portion of the expansion cone launcher 135 and the shoe 140 from the region outside of the apparatus 100.

An expandable tubular member 155 is coupled to the upper portion of the expansion cone launcher 135. One or more sealing members 160a and 160b are coupled to the exterior of the upper portion of the expandable tubular member 155. In several alternative embodiments, the sealing members 160a and 160b may include elastomeric elements and/or metallic elements and/or composite elements. In several alternative 5 embodiments, one or more anchoring elements may substituted for, or used in addition to, the sealing members 160a and 160b.

In a preferred embodiment, the support member 105, the expansion cone 115, the expansion cone launcher 135, the shoe 140, and the expandable tubular member 155 are 10 provided substantially as disclosed in one or more of the following: (1) U.S. patent application serial no. 09/454,139, attorney docket no. 25791.03.02, filed on 12/3/1999, (2) U.S. patent application serial no. 09/510,913, attorney docket no. 25791.7.02, filed on 2/23/2000, (3) U.S. patent application serial no. 09/502,350, attorney docket no. 25791.8.02, filed on 2/10/2000, (4) U.S. patent application serial no. 09/440,338, attorney 15 docket no. 25791.9.02, filed on 11/15/1999, (5) U.S. patent application serial no. 09/523,460, attorney docket no. 25791.11.02, filed on 3/10/2000, (6) U.S. patent application serial no. 09/512,895, attorney docket no. 25791.12.02, filed on 2/24/2000, (7) U.S. patent application serial no. 09/511,941, attorney docket no. 25791.16.02, filed on 2/24/2000, (8) U.S. patent application serial no. 09/588,946, attorney docket no. 20 25791.17.02, filed on 6/7/2000, (9) U.S. patent application serial no. 09/559,122, attorney docket no. 25791.23.02, filed on 4/26/2000, (10) PCT patent application serial no. PCT/US00/18635, attorney docket no. 25791.25.02, filed on 7/9/2000, (11) U.S. provisional patent application serial no. 60/162,671, attorney docket no. 25791.27, filed on 11/1/1999, (12) U.S. provisional patent application serial no. 60/154,047, attorney docket 25 no. 25791.29, filed on 9/16/1999, (13) U.S. provisional patent application serial no. 60/159,082, attorney docket no. 25791.34, filed on 10/12/1999, (14) U.S. provisional patent application serial no. 60/159,039, attorney docket no. 25791.36, filed on 10/12/1999, (15) U.S. provisional patent application serial no. 60/159,033, attorney docket no. 25791.37, filed on 10/12/1999, (16) U.S. provisional patent application serial no. 30 _____, attorney docket no. 25791.38, filed on 6/19/2000, (17) U.S. provisional patent application serial no. 60/165,228, attorney docket no. 25791.39, filed on 11/12/1999, (18) U.S. provisional patent application serial no. _____, attorney docket no. 25791.45, filed on 7/28/2000, (19) U.S. provisional patent application serial no.

_____, attorney docket no. 25791.46, filed on 7/28/2000, and (20) U.S. provisional patent application serial no. _____, attorney docket no. 25791.47, filed on 9/18/2000, the disclosures of which are incorporated herein by reference.

As illustrated in Fig. 1b, in a preferred embodiment, during placement of the apparatus 100 within the wellbore 10, fluidic materials 165 within the wellbore 10 are conveyed through the apparatus 100 through the passages 110, 120 and 145 to a location above the apparatus 100. In this manner, surge pressures during placement of the apparatus 100 within the wellbore 10 are reduced. In a preferred embodiment, the apparatus 100 is initially positioned within the wellbore 10 such that the top portion of the tubular member 155 overlaps with the preexisting casing 15. In this manner, the upper portion of the expandable tubular member 155 may be radially expanded into contact with and coupled to the preexisting casing 15. As will be recognized by persons having ordinary skill in the art, the precise initial position of the expandable tubular member 155 will vary as a function of the amount of radial expansion, the amount of axial shrinkage during radial expansion, and the material properties of the expandable tubular member.

As illustrated in Fig. 1c, a fluidic material 170 may then be injected through the apparatus 100 through the passages 110, 120, and 145 in order to test the proper operation of these passages.

As illustrated in Fig. 1d, a hardenable fluidic sealing material 175 may then be injected through the apparatus 100 through the passages 110, 120 and 145 into the annulus between the apparatus and the wellbore 10. In this manner, an annular barrier to fluid migration into and out of the wellbore 10 may be formed around the radially expanded expansion cone launcher 135 and expandable tubular member 155. The hardenable fluidic sealing material may include, for example, a cement mixture. In several alternative embodiments, the injection of the hardenable fluidic sealing material 175 may be omitted. In several alternative embodiments, the hardenable fluidic sealing material 175 is compressible, before, during and/or after, the curing process.

As illustrated in Fig. 1e, a non-hardenable fluidic material 180 may then be injected into the apparatus through the passages 110 and 120. A ball plug 185, or other similar device, may then be injected with the fluidic material 180 to thereby seal off the passage 145. In this manner, the region 150 may be pressurized by the continued injection of the fluidic material 180 into the apparatus 100.

As illustrated in Fig. 1f, the continued injection of the fluidic material 180 into the apparatus 100 causes the expansion cone launcher 135 and expandable tubular member 155 to be plastically deformed and radially expanded off of the over-expansion sleeve 130. In this manner, the expansion cone 115 and over-expansion sleeve 130 are displaced
5 relative to the expansion cone launcher 135 and expandable tubular member 155 in the axial direction.

After a predetermined time period and/or after a predetermined axial displacement of the expansion cone 115 relative to the expansion cone launcher 135 and expandable tubular member 155, the over-expansion sleeve 130 may be removed from the outer
10 conical surface 125 of the expansion cone 115 by the application of a predetermined upward shock load to the support member 105. In a preferred embodiment, the shock load causes the frangible over-expansion sleeve 130 to fracture into small pieces that are then forced off of the outer conical surface 125 of the expansion cone 115 by the continued
15 pressurization of the region 150. In a preferred embodiment, the pieces of the over-expansion sleeve 130 are pulverized into grains of material by the continued pressurization of the region 150.

Referring to Fig. 1g, following the removal of the frangible over-expansion sleeve 130, the continued pressurization of the region 150 causes the expandable tubular member 155 to be plastically deformed and radially expanded and extruded off of the outer conical
20 surface 125 of the expansion cone 115. Note that the amount of radial expansion provided by the outer conical surface 125 of expansion cone 115 is less than the amount of radial expansion provided by the combination of the over-expansion sleeve 130 and the expansion cone 115. In this manner, as illustrated in Fig. 1h, a recess 185 is formed in the radially expanded tubular member 155.

25 After completing the plastic deformation and radial expansion of the tubular member 155, the hardenable fluidic sealing material is allowed to cure to thereby form an annular body 190 that provides a barrier to fluid flow into or out of the wellbore 10.

Referring to Fig. 1i, the shoe 140 may then removed by drilling out the shoe using a conventional drilling device. A new section of the wellbore 10 may also be drilled out in
30 order to permit additional expandable tubular members to be coupled to the bottom portion of the plastically deformed and radially expanded tubular member 155.

Referring to Fig. 1j, a tubular member 200 may then be plastically deformed and radially expanded using any number of conventional methods of radially expanding a

tubular member. In a preferred embodiment, the upper portion of the radially expanded tubular member 200 overlaps with and mates with the recessed portion 185 of the tubular member 155. In a preferred embodiment, one or more sealing members 205 are coupled to the exterior surface of the upper portion of the tubular member 200. In a preferred
5 embodiment, the sealing members 205 seal the interface between the upper portion of the tubular member 200 and the recessed portion 185 of the tubular member 155. In several alternative embodiments, the sealing members 205 may include elastomeric elements and/or metallic elements and/or composite elements. In several alternative embodiments, one or more anchoring elements may substituted for, or used in addition to, the sealing
10 members 205. In a preferred embodiment, an annular body 210 of a hardenable fluidic sealing material is also formed around the tubular member 200 using one or more conventional methods.

In a preferred embodiment, the tubular member 200 is plastically deformed and radially expanded, and the annular body 210 is formed using one or more of the apparatus
15 and methods disclosed in the following: (1) U.S. patent application serial no. 09/454,139, attorney docket no. 25791.03.02, filed on 12/3/1999, (2) U.S. patent application serial no. 09/510,913, attorney docket no. 25791.7.02, filed on 2/23/2000, (3) U.S. patent application serial no. 09/502,350, attorney docket no. 25791.8.02, filed on 2/10/2000, (4) U.S. patent application serial no. 09/440,338, attorney docket no. 25791.9.02, filed on 11/15/1999, (5)
20 U.S. patent application serial no. 09/523,460, attorney docket no. 25791.11.02, filed on 3/10/2000, (6) U.S. patent application serial no. 09/512,895, attorney docket no. 25791.12.02, filed on 2/24/2000, (7) U.S. patent application serial no. 09/511,941, attorney docket no. 25791.16.02, filed on 2/24/2000, (8) U.S. patent application serial no. 09/588,946, attorney docket no. 25791.17.02, filed on 6/7/2000, (9) U.S. patent application
25 serial no. 09/559,122, attorney docket no. 25791.23.02, filed on 4/26/2000, (10) PCT patent application serial no. PCT/US00/18635, attorney docket no. 25791.25.02, filed on 7/9/2000, (11) U.S. provisional patent application serial no. 60/162,671, attorney docket no. 25791.27, filed on 11/1/1999, (12) U.S. provisional patent application serial no. 60/154,047, attorney docket no. 25791.29, filed on 9/16/1999, (13) U.S. provisional patent
30 application serial no. 60/159,082, attorney docket no. 25791.34, filed on 10/12/1999, (14) U.S. provisional patent application serial no. 60/159,039, attorney docket no. 25791.36, filed on 10/12/1999, (15) U.S. provisional patent application serial no. 60/159,033, attorney docket no. 25791.37, filed on 10/12/1999, (16) U.S. provisional patent application

serial no. _____, attorney docket no. 25791.38, filed on 6/19/2000, (17) U.S. provisional patent application serial no. 60/165,228, attorney docket no. 25791.39, filed on 11/12/1999, (18) U.S. provisional patent application serial no. _____, attorney docket no. 25791.45, filed on 7/28/2000, (19) U.S. provisional patent application serial no. _____, attorney docket no. 25791.46, filed on 7/28/2000, and (20) U.S. provisional patent application serial no. _____, attorney docket no. 25791.47, filed on 9/18/2000, the disclosures of which are incorporated herein by reference.

In an alternative embodiment, the annular body 210 may be omitted. In several alternative embodiments, the annular body 210 may be radially compressed before, during and/or after curing.

Referring to Fig. 1k, an expansion cone 215 may then be driven in a downward direction by fluid pressure and/or by a support member 220 to plastically deform and radially expand the tubular member 200 such that the interior diameter of the tubular members 155 and 200 are substantially equal. In this manner, as illustrated in Fig. 11, a mono-diameter wellbore casing may be formed. In a preferred embodiment, during the displacement of the expansion cone 215 in the downward direction, fluidic materials displaced by the expansion cone are conveyed out of the wellbore by an internal passage 220a defined within the support member 220.

Referring to Figs. 2a and 2b, in an alternative embodiment, an apparatus 300 for radially expanding a tubular member may then be positioned within the wellbore 10. The apparatus 300 includes a tubular support member 305 defining a passage 310 for conveying fluidic materials. An expansion cone 315 defining a passage 320 and having an outer conical surface 325 for radially expanding tubular members is coupled to an end of the tubular support member 305. An annular conical over-expansion insert 330 mates with and is removably coupled to the outer conical surface 325 of the expansion cone 315.

An expansion cone launcher 335 is movably coupled to and supported by the expansion cone 315 and the over-expansion insert 330. The expansion cone launcher 335 includes an upper portion having an upper outer diameter, an intermediate portion that mates with the expansion cone 315 and the over-expansion insert 330, an a lower portion having a lower outer diameter. The lower outer diameter is greater than the upper outer diameter. A shoe 340 defining a valveable passage 345 is coupled to the lower portion of the expansion cone launcher 335. In a preferred embodiment, the valveable passage 345 may be controllably closed in order to fluidically isolate a region 350 below the expansion

cone 315 and bounded by the lower portion of the expansion cone launcher 335 and the shoe 340 from the region outside of the apparatus 300.

In a preferred embodiment, as illustrated in Fig. 3, the over-expansion insert 330 includes a plurality of spaced-apart arcuate inserts 330a, 330b, 330c and 330d that are
5 positioned between the outer conical surface 325 of the expansion cone 315 and the inner surface of the intermediate portion of the expansion cone launcher 335. In this manner, the relative axial displacement of the expansion cone 315 and the expansion cone launcher 335 will cause the expansion cone to over-expand the intermediate portion of the expansion cone launcher. In this manner, a recess may be formed in the radially expanded
10 expansion cone launcher 335. In several alternative embodiments, the inserts 330a, 330b, 330c, and 330d fall out of the recess and/or are removed from the recess using a conventional retrieval tool upon the completion of the radial expansion process.

In an alternative embodiment, as illustrated in Fig. 3a, the over expansion insert 330 further includes intermediate resilient members 331a, 331b, 331c, and 331d for
15 resiliently coupling the inserts 330a, 330b, 330c, and 330d. In this manner, upon the completion of the radial expansion process, the resilient force exerted by the resilient members 331 causes the over-expansion insert to collapse in the radial direction and thereby fall out of the recess.

An expandable tubular member 355 is coupled to the upper portion of the
20 expansion cone launcher 335. One or more sealing members 360a and 360b are coupled to the exterior of the upper portion of the expandable tubular member 355. In several alternative embodiments, the sealing members 360a and 360b may include elastomeric elements and/or metallic elements and/or composite elements. In several alternative embodiments, one or more anchoring elements may substituted for, or used in addition to,
25 the sealing members 360a and 360b.

In a preferred embodiment, the support member 305, the expansion cone 315, the expansion cone launcher 335, the shoe 340, and the expandable tubular member 355 are provided substantially as disclosed in one or more of the following: (1) U.S. patent application serial no. 09/454,139, attorney docket no. 25791.03.02, filed on 12/3/1999, (2)
30 U.S. patent application serial no. 09/510,913, attorney docket no. 25791.7.02, filed on 2/23/2000, (3) U.S. patent application serial no. 09/502,350, attorney docket no. 25791.8.02, filed on 2/10/2000, (4) U.S. patent application serial no. 09/440,338, attorney docket no. 25791.9.02, filed on 11/15/1999, (5) U.S. patent application serial no.

09/523,460, attorney docket no. 25791.11.02, filed on 3/10/2000, (6) U.S. patent application serial no. 09/512,895, attorney docket no. 25791.12.02, filed on 2/24/2000, (7) U.S. patent application serial no. 09/511,941, attorney docket no. 25791.16.02, filed on 2/24/2000, (8) U.S. patent application serial no. 09/588,946, attorney docket no. 25791.17.02, filed on 6/7/2000, (9) U.S. patent application serial no. 09/559,122, attorney docket no. 25791.23.02, filed on 4/26/2000, (10) PCT patent application serial no. PCT/US00/18635, attorney docket no. 25791.25.02, filed on 7/9/2000, (11) U.S. provisional patent application serial no. 60/162,671, attorney docket no. 25791.27, filed on 11/1/1999, (12) U.S. provisional patent application serial no. 60/154,047, attorney docket no. 25791.29, filed on 9/16/1999, (13) U.S. provisional patent application serial no. 60/159,082, attorney docket no. 25791.34, filed on 10/12/1999, (14) U.S. provisional patent application serial no. 60/159,039, attorney docket no. 25791.36, filed on 10/12/1999, (15) U.S. provisional patent application serial no. 60/159,033, attorney docket no. 25791.37, filed on 10/12/1999, (16) U.S. provisional patent application serial no. _____, attorney docket no. 25791.38, filed on 6/19/2000, (17) U.S. provisional patent application serial no. 60/165,228, attorney docket no. 25791.39, filed on 11/12/1999, (18) U.S. provisional patent application serial no. _____, attorney docket no. 25791.45, filed on 7/28/2000, (19) U.S. provisional patent application serial no. _____, attorney docket no. 25791.46, filed on 7/28/2000, and (20) U.S. provisional patent application serial no. _____, attorney docket no. 25791.47, filed on 9/18/2000, the disclosures of which are incorporated herein by reference.

As illustrated in Fig. 2b, in a preferred embodiment, during placement of the apparatus 300 within the wellbore 10, fluidic materials 365 within the wellbore 10 are conveyed through the apparatus 300 through the passages 310, 320 and 345 to a location above the apparatus 300. In this manner, surge pressures during placement of the apparatus 300 within the wellbore 10 are reduced. In a preferred embodiment, the apparatus 300 is initially positioned within the wellbore 10 such that the top portion of the tubular member 355 overlaps with the preexisting casing 15. In this manner, the upper portion of the expandable tubular member 355 may be radially expanded into contact with and coupled to the preexisting casing 15. As will be recognized by persons having ordinary skill in the art, the precise initial position of the expandable tubular member 355 will vary as a function of the amount of radial expansion, the amount of axial shrinkage during radial expansion, and the material properties of the expandable tubular member.

As illustrated in Fig. 2c, a fluidic material 370 may then be injected through the apparatus 300 through the passages 310, 320, and 345 in order to test the proper operation of these passages.

As illustrated in Fig. 2d, a hardenable fluidic sealing material 375 may then be
5 injected through the apparatus 300 through the passages 310, 320 and 345 into the annulus between the apparatus and the wellbore 10. In this manner, an annular barrier to fluid migration into and out of the wellbore 10 may be formed around the radially expanded expansion cone launcher 335 and expandable tubular member 355. The hardenable fluidic sealing material may include, for example, a cement mixture. In several alternative
10 embodiments, the injection of the hardenable fluidic sealing material 375 may be omitted. In several alternative embodiments, the hardenable fluidic sealing material 375 is compressible, before, during and/or after, the curing process.

As illustrated in Fig. 2e, a non-hardenable fluidic material 380 may then be injected into the apparatus through the passages 310 and 320. A ball plug 385, or other
15 similar device, may then be injected with the fluidic material 380 to thereby seal off the passage 345. In this manner, the region 350 may be pressurized by the continued injection of the fluidic material 380 into the apparatus 300.

As illustrated in Fig. 2f, the continued injection of the fluidic material 380 into the apparatus 300 causes the expansion cone launcher 335 to be plastically deformed and
20 radially expanded off of the over-expansion insert 330. In this manner, the expansion cone 315 is displaced relative to the expansion cone launcher 335 and expandable tubular member 355 in the axial direction.

Once the radial expansion process has progressed beyond the over-expansion insert 330, the radial expansion of the expansion cone launcher 335 and expandable tubular
25 member 355 is provided solely by the outer conical surface 325 of the expansion cone 315. Note that the amount of radial expansion provided by the outer conical surface 325 of expansion cone 315 is less than the amount of radial expansion provided by the combination of the over-expansion insert 330 and the expansion cone 315. In this manner, as illustrated in Fig. 2g, a recess 390 is formed in the radially expanded tubular member
30 355.

In several alternative embodiments, the over-expansion insert 330 is removed from the recess 390 by falling out and/or removal using a conventional retrieval tool. In an alternative embodiment, the resilient force provided by the resilient members 331a, 331b,

331c, and 331d cause the insert 330 to collapse in the radial direction and thereby fall out of the recess 390. In an alternative embodiment, as illustrated in Fig. 4, one or more resilient hooks 395a and 395b are coupled to the bottom of the expansion cone 315 for retrieving the over-expansion insert 330 during or after the completion of the radial expansion process.

After completing the plastic deformation and radial expansion of the tubular member 355, the hardenable fluidic sealing material is allowed to cure to thereby form an annular body 400 that provides a barrier to fluid flow into or out of the wellbore 10.

Referring to Fig. 2h, the shoe 340 may then removed by drilling out the shoe using a conventional drilling device. A new section of the wellbore 10 may also be drilled out in order to permit additional expandable tubular members to be coupled to the bottom portion of the plastically deformed and radially expanded tubular member 355.

Referring to Fig. 2i, a tubular member 405 may then be plastically deformed and radially expanded using any number of conventional methods of radially expanding a tubular member. In a preferred embodiment, the upper portion of the radially expanded tubular member 405 overlaps with and mates with the recessed portion 390 of the tubular member 355. In a preferred embodiment, one or more sealing members 410 are coupled to the exterior surface of the upper portion of the tubular member 405. In a preferred embodiment, the sealing members 410 seal the interface between the upper portion of the tubular member 405 and the recessed portion 390 of the tubular member 355. In several alternative embodiments, the sealing members 410 may include elastomeric elements and/or metallic elements and/or composite elements. In several alternative embodiments, one or more anchoring elements may substituted for, or used in addition to, the sealing members 410. In a preferred embodiment, an annular body 415 of a hardenable fluidic sealing material is also formed around the tubular member 405 using one or more conventional methods.

In a preferred embodiment, the tubular member 405 is plastically deformed and radially expanded, and the annular body 415 is formed using one or more of the apparatus and methods disclosed in the following: (1) U.S. patent application serial no. 09/454,139, attorney docket no. 25791.03.02, filed on 12/3/1999, (2) U.S. patent application serial no. 09/510,913, attorney docket no. 25791.7.02, filed on 2/23/2000, (3) U.S. patent application serial no. 09/502,350, attorney docket no. 25791.8.02, filed on 2/10/2000, (4) U.S. patent application serial no. 09/440,338, attorney docket no. 25791.9.02, filed on 11/15/1999, (5)

- U.S. patent application serial no. 09/523,460, attorney docket no. 25791.11.02, filed on 3/10/2000, (6) U.S. patent application serial no. 09/512,895, attorney docket no. 25791.12.02, filed on 2/24/2000, (7) U.S. patent application serial no. 09/511,941, attorney docket no. 25791.16.02, filed on 2/24/2000, (8) U.S. patent application serial no.
- 5 09/588,946, attorney docket no. 25791.17.02, filed on 6/7/2000, (9) U.S. patent application serial no. 09/559,122, attorney docket no. 25791.23.02, filed on 4/26/2000, (10) PCT patent application serial no. PCT/US00/18635, attorney docket no. 25791.25.02, filed on 7/9/2000, (11) U.S. provisional patent application serial no. 60/162,671, attorney docket no. 25791.27, filed on 11/1/1999, (12) U.S. provisional patent application serial no.
- 10 60/154,047, attorney docket no. 25791.29, filed on 9/16/1999, (13) U.S. provisional patent application serial no. 60/159,082, attorney docket no. 25791.34, filed on 10/12/1999, (14) U.S. provisional patent application serial no. 60/159,039, attorney docket no. 25791.36, filed on 10/12/1999, (15) U.S. provisional patent application serial no. 60/159,033, attorney docket no. 25791.37, filed on 10/12/1999, (16) U.S. provisional patent application
- 15 serial no. _____, attorney docket no. 25791.38, filed on 6/19/2000, (17) U.S. provisional patent application serial no. 60/165,228, attorney docket no. 25791.39, filed on 11/12/1999, (18) U.S. provisional patent application serial no. _____, attorney docket no. 25791.45, filed on 7/28/2000, (19) U.S. provisional patent application serial no. _____, attorney docket no. 25791.46, filed on 7/28/2000, and (20) U.S.
- 20 provisional patent application serial no. _____, attorney docket no. 25791.47, filed on 9/18/2000, the disclosures of which are incorporated herein by reference.

In an alternative embodiment, the annular body 415 may be omitted. In several alternative embodiments, the annular body 415 may be radially compressed before, during and/or after curing.

- 25 Referring to Fig. 2j, an expansion cone 420 may then be driven in a downward direction by fluid pressure and/or by a support member 425 to plastically deform and radially expand the tubular member 405 such that the interior diameter of the tubular members 355 and 405 are substantially equal. In this manner, as illustrated in Fig. 2k, a mono-diameter wellbore casing may be formed. In a preferred embodiment, during the
- 30 displacement of the expansion cone 420 in the downward direction, fluidic materials displaced by the expansion cone are conveyed out of the wellbore by an internal passage 425a defined within the support member 425.

Referring to Figs 5a-5b, in an alternative embodiment, a tubular member 500 having a shoe 505 may be plastically deformed and radially expanded and thereby coupled to the preexisting section of wellbore casing 15 using any number of conventional methods. An annular body of a fluidic sealing material 510 may also be formed around the tubular member 500 using any number of conventional methods. In a preferred embodiment, the tubular member 500 is plastically deformed and radially expanded and the annular body 510 is formed using one or more of the methods and apparatus disclosed in one or more of the following: (1) U.S. patent application serial no. 09/454,139, attorney docket no. 25791.03.02, filed on 12/3/1999, (2) U.S. patent application serial no. 09/510,913, attorney docket no. 25791.7.02, filed on 2/23/2000, (3) U.S. patent application serial no. 09/502,350, attorney docket no. 25791.8.02, filed on 2/10/2000, (4) U.S. patent application serial no. 09/440,338, attorney docket no. 25791.9.02, filed on 11/15/1999, (5) U.S. patent application serial no. 09/523,460, attorney docket no. 25791.11.02, filed on 3/10/2000, (6) U.S. patent application serial no. 09/512,895, attorney docket no. 25791.12.02, filed on 2/24/2000, (7) U.S. patent application serial no. 09/511,941, attorney docket no. 25791.16.02, filed on 2/24/2000, (8) U.S. patent application serial no. 09/588,946, attorney docket no. 25791.17.02, filed on 6/7/2000, (9) U.S. patent application serial no. 09/559,122, attorney docket no. 25791.23.02, filed on 4/26/2000, (10) PCT patent application serial no. PCT/US00/18635, attorney docket no. 25791.25.02, filed on 7/9/2000, (11) U.S. provisional patent application serial no. 60/162,671, attorney docket no. 25791.27, filed on 11/1/1999, (12) U.S. provisional patent application serial no. 60/154,047, attorney docket no. 25791.29, filed on 9/16/1999, (13) U.S. provisional patent application serial no. 60/159,082, attorney docket no. 25791.34, filed on 10/12/1999, (14) U.S. provisional patent application serial no. 60/159,039, attorney docket no. 25791.36, filed on 10/12/1999, (15) U.S. provisional patent application serial no. 60/159,033, attorney docket no. 25791.37, filed on 10/12/1999, (16) U.S. provisional patent application serial no. _____, attorney docket no. 25791.38, filed on 6/19/2000, (17) U.S. provisional patent application serial no. 60/165,228, attorney docket no. 25791.39, filed on 11/12/1999, (18) U.S. provisional patent application serial no. _____, attorney docket no. 25791.45, filed on 7/28/2000, (19) U.S. provisional patent application serial no. _____, attorney docket no. 25791.46, filed on 7/28/2000, and (20) U.S. provisional patent application serial no. _____, attorney docket no. 25791.47, filed on 9/18/2000, the disclosures of which are incorporated herein by reference.

In several alternative embodiments, the annular body 510 may be omitted or may be compressible before, during, or after curing.

Referring to Figs. 5c and 5d, a conventional inflatable bladder 515 may then be positioned within the tubular member 500 and inflated to a sufficient operating pressure to
5 plastically deform and radially expand a portion of the tubular member to thereby form a recess 520 in the tubular member.

Referring to Figs. 5e and 5f, the inflatable bladder 515 may then be removed and the shoe 505 drilled out using a conventional drilling device.

Referring to Fig. 5g, an additional tubular member 525 may then be plastically
10 deformed and radially expanded in a conventional manner and/or by using one or more of the methods and apparatus described above in order to form a mono-diameter wellbore casing. Before, during or after the radial expansion of the tubular member 525, an annular body 530 of a fluidic sealing material may be formed around the tubular member in a conventional manner and/or by using one or more of the methods and apparatus described
15 above.

In several alternative embodiments, the inflatable bladder 515 may be coupled to the bottom of an expansion cone in order to permit the over-expansion process to be performed during the radial expansion process implemented using the expansion cone.

Referring to Figs 6a-6b, in an alternative embodiment, a tubular member 600
20 having a shoe 605 may be plastically deformed and radially expanded and thereby coupled to the preexisting section of wellbore casing 15 using any number of conventional methods. An annular body of a fluidic sealing material 610 may also be formed around the tubular member 600 using any number of conventional methods. In a preferred
25 embodiment, the tubular member 600 is plastically deformed and radially expanded and the annular body 610 is formed using one or more of the methods and apparatus disclosed in one or more of the following: (1) U.S. patent application serial no. 09/454,139, attorney docket no. 25791.03.02, filed on 12/3/1999, (2) U.S. patent application serial no. 09/510,913, attorney docket no. 25791.7.02, filed on 2/23/2000, (3) U.S. patent application serial no. 09/502,350, attorney docket no. 25791.8.02, filed on 2/10/2000, (4) U.S. patent
30 application serial no. 09/440,338, attorney docket no. 25791.9.02, filed on 11/15/1999, (5) U.S. patent application serial no. 09/523,460, attorney docket no. 25791.11.02, filed on 3/10/2000, (6) U.S. patent application serial no. 09/512,895, attorney docket no. 25791.12.02, filed on 2/24/2000, (7) U.S. patent application serial no. 09/511,941, attorney

docket no. 25791.16.02, filed on 2/24/2000, (8) U.S. patent application serial no. 09/588,946, attorney docket no. 25791.17.02, filed on 6/7/2000, (9) U.S. patent application serial no. 09/559,122, attorney docket no. 25791.23.02, filed on 4/26/2000, (10) PCT patent application serial no. PCT/US00/18635, attorney docket no. 25791.25.02, filed on 5 7/9/2000, (11) U.S. provisional patent application serial no. 60/162,671, attorney docket no. 25791.27, filed on 11/1/1999, (12) U.S. provisional patent application serial no. 60/154,047, attorney docket no. 25791.29, filed on 9/16/1999, (13) U.S. provisional patent application serial no. 60/159,082, attorney docket no. 25791.34, filed on 10/12/1999, (14) U.S. provisional patent application serial no. 60/159,039, attorney docket no. 25791.36, 10 filed on 10/12/1999, (15) U.S. provisional patent application serial no. 60/159,033, attorney docket no. 25791.37, filed on 10/12/1999, (16) U.S. provisional patent application serial no. _____, attorney docket no. 25791.38, filed on 6/19/2000, (17) U.S. provisional patent application serial no. 60/165,228, attorney docket no. 25791.39, filed on 11/12/1999, (18) U.S. provisional patent application serial no. _____, attorney 15 docket no. 25791.45, filed on 7/28/2000, (19) U.S. provisional patent application serial no. _____, attorney docket no. 25791.46, filed on 7/28/2000, and (20) U.S. provisional patent application serial no. _____, attorney docket no. 25791.47, filed on 9/18/2000, the disclosures of which are incorporated herein by reference.

In several alternative embodiments, the annular body 610 may be omitted or may 20 be compressible before, during, or after curing.

Referring to Figs. 6c and 6d, a conventional roller expansion device 615 may then be positioned within the tubular member 600 and operated in a conventional manner apply a radial force to the interior surface of the tubular member 600 to plastically deform and radially expand a portion of the tubular member to thereby form a recess 620 in the tubular 25 member. As will be recognized by persons having ordinary skill in the art, a roller expansion device typically utilizes one or more rollers that, through rotation of the device, apply a radial force to the interior surfaces of a tubular member. In several alternative embodiments, the roller expansion device 615 may include eccentric rollers such as, for example, as disclosed in U.S. Pat. Nos. 5,014,779 and 5,083,608, the disclosures of which 30 are incorporated herein by reference.

Referring to Figs. 6d and 6e, the roller expansion device 615 may then be removed and the shoe 605 drilled out using a conventional drilling device.

Referring to Fig. 6f, an additional tubular member 625 may then be plastically deformed and radially expanded in a conventional manner and/or by using one or more of the methods and apparatus described above in order to form a mono-diameter wellbore casing. Before, during or after the radial expansion of the tubular member 625, an annular body 630 of a fluidic sealing material may be formed around the tubular member in a conventional manner and/or by using one or more of the methods and apparatus described above.

In several alternative embodiments, the roller expansion device 615 may be coupled to the bottom of an expansion cone in order to permit the over-expansion process to be performed during the radial expansion process implemented using the expansion cone.

Referring initially to Fig. 7a, a wellbore 10 includes a preexisting wellbore casing 15. The wellbore 10 may be oriented in any orientation from the vertical to the horizontal. The preexisting wellbore casing 15 may be coupled to the upper portion of the wellbore 10 using any number of conventional methods. In a preferred embodiment, the wellbore casing 15 is coupled to the upper portion of the wellbore 10 using one or more of the methods and apparatus disclosed in one or more of the following: (1) U.S. patent application serial no. 09/454,139, attorney docket no. 25791.03.02, filed on 12/3/1999, (2) U.S. patent application serial no. 09/510,913, attorney docket no. 25791.7.02, filed on 2/23/2000, (3) U.S. patent application serial no. 09/502,350, attorney docket no. 25791.8.02, filed on 2/10/2000, (4) U.S. patent application serial no. 09/440,338, attorney docket no. 25791.9.02, filed on 11/15/1999, (5) U.S. patent application serial no. 09/523,460, attorney docket no. 25791.11.02, filed on 3/10/2000, (6) U.S. patent application serial no. 09/512,895, attorney docket no. 25791.12.02, filed on 2/24/2000, (7) U.S. patent application serial no. 09/511,941, attorney docket no. 25791.16.02, filed on 2/24/2000, (8) U.S. patent application serial no. 09/588,946, attorney docket no. 25791.17.02, filed on 6/7/2000, (9) U.S. patent application serial no. 09/559,122, attorney docket no. 25791.23.02, filed on 4/26/2000, (10) PCT patent application serial no. PCT/US00/18635, attorney docket no. 25791.25.02, filed on 7/9/2000, (11) U.S. provisional patent application serial no. 60/162,671, attorney docket no. 25791.27, filed on 11/1/1999, (12) U.S. provisional patent application serial no. 60/154,047, attorney docket no. 25791.29, filed on 9/16/1999, (13) U.S. provisional patent application serial no. 60/159,082, attorney docket no. 25791.34, filed on 10/12/1999, (14) U.S. provisional

patent application serial no. 60/159,039, attorney docket no. 25791.36, filed on 10/12/1999, (15) U.S. provisional patent application serial no. 60/159,033, attorney docket no. 25791.37, filed on 10/12/1999, (16) U.S. provisional patent application serial no. _____, attorney docket no. 25791.38, filed on 6/19/2000, (17) U.S.

5 provisional patent application serial no. 60/165,228, attorney docket no. 25791.39, filed on 11/12/1999, (18) U.S. provisional patent application serial no. _____, attorney docket no. 25791.45, filed on 7/28/2000, (19) U.S. provisional patent application serial no. _____, attorney docket no. 25791.46, filed on 7/28/2000, and (20) U.S. provisional patent application serial no. _____, attorney docket no. 25791.47, filed on 9/18/2000, the disclosures of which are incorporated herein by reference. More generally, the preexisting wellbore casing 15 may be coupled to another preexisting wellbore casing and/or may include one or more concentrically positioned tubular members.

Referring to Fig. 7b, an apparatus 700 for radially expanding a tubular member may then be positioned within the wellbore 10. The apparatus 700 includes a tubular support member 705 defining a passage 710 for conveying fluidic materials. An expansion cone 715 defining a passage 720 and having an outer conical surface 725 for radially expanding tubular members is coupled to an end of the tubular support member 705.

20 An expansion cone launcher 735 is movably coupled to and supported by the expansion cone 715. The expansion cone launcher 735 includes an upper portion 735a having an upper outer diameter, an intermediate portion 735b that mates with the expansion cone 715, and a lower portion 735c having a lower outer diameter. The lower outer diameter is greater than the upper outer diameter. The expansion cone launcher 735 further includes a recessed portion 735d having an outer diameter that is less than the lower outer diameter.

A shoe 740 defining a valveable passage 745 is coupled to the lower portion of the expansion cone launcher 735. In a preferred embodiment, the valveable passage 745 may be controllably closed in order to fluidically isolate a region 750 below the expansion cone 715 and bounded by the lower portion 735c of the expansion cone launcher 735 and the shoe 740 from the region outside of the apparatus 700.

An expandable tubular member 755 is coupled to the upper portion 735a of the expansion cone launcher 735. One or more sealing members 760a and 760b may be

coupled to the exterior of the upper portion of the expandable tubular member 755. In several alternative embodiments, the sealing members 760a and 760b may include elastomeric elements and/or metallic elements and/or composite elements. In several alternative embodiments, one or more anchoring elements may substituted for, or used in addition to, the sealing members 760a and 760b.

In a preferred embodiment, the support member 705, the expansion cone 715, the expansion cone launcher 735, the shoe 740, and the expandable tubular member 755 are provided substantially as disclosed in one or more of the following: (1) U.S. patent application serial no. 09/454,139, attorney docket no. 25791.03.02, filed on 12/3/1999, (2) U.S. patent application serial no. 09/510,913, attorney docket no. 25791.7.02, filed on 2/23/2000, (3) U.S. patent application serial no. 09/502,350, attorney docket no. 25791.8.02, filed on 2/10/2000, (4) U.S. patent application serial no. 09/440,338, attorney docket no. 25791.9.02, filed on 11/15/1999, (5) U.S. patent application serial no. 09/523,460, attorney docket no. 25791.11.02, filed on 3/10/2000, (6) U.S. patent application serial no. 09/512,895, attorney docket no. 25791.12.02, filed on 2/24/2000, (7) U.S. patent application serial no. 09/511,941, attorney docket no. 25791.16.02, filed on 2/24/2000, (8) U.S. patent application serial no. 09/588,946, attorney docket no. 25791.17.02, filed on 6/7/2000, (9) U.S. patent application serial no. 09/559,122, attorney docket no. 25791.23.02, filed on 4/26/2000, (10) PCT patent application serial no. PCT/US00/18635, attorney docket no. 25791.25.02, filed on 7/9/2000, (11) U.S. provisional patent application serial no. 60/162,671, attorney docket no. 25791.27, filed on 11/1/1999, (12) U.S. provisional patent application serial no. 60/154,047, attorney docket no. 25791.29, filed on 9/16/1999, (13) U.S. provisional patent application serial no. 60/159,082, attorney docket no. 25791.34, filed on 10/12/1999, (14) U.S. provisional patent application serial no. 60/159,039, attorney docket no. 25791.36, filed on 10/12/1999, (15) U.S. provisional patent application serial no. 60/159,033, attorney docket no. 25791.37, filed on 10/12/1999, (16) U.S. provisional patent application serial no. _____, attorney docket no. 25791.38, filed on 6/19/2000, (17) U.S. provisional patent application serial no. 60/165,228, attorney docket no. 25791.39, filed on 11/12/1999, (18) U.S. provisional patent application serial no. _____, attorney docket no. 25791.45, filed on 7/28/2000, (19) U.S. provisional patent application serial no. _____, attorney docket no. 25791.46, filed on 7/28/2000, and (20) U.S.

provisional patent application serial no. _____, attorney docket no. 25791.47, filed on 9/18/2000, the disclosures of which are incorporated herein by reference.

As illustrated in Fig. 7b, in a preferred embodiment, during placement of the apparatus 700 within the wellbore 10, fluidic materials 765 within the wellbore 10 are conveyed through the apparatus 700 through the passages 710, 720 and 745 to a location above the apparatus 700. In this manner, surge pressures during placement of the apparatus 700 within the wellbore 10 are reduced. In a preferred embodiment, the apparatus 700 is initially positioned within the wellbore 10 such that the top portion of the tubular member 755 overlaps with the preexisting casing 15. In this manner, the upper portion of the expandable tubular member 755 may be radially expanded into contact with and coupled to the preexisting casing 15. As will be recognized by persons having ordinary skill in the art, the precise initial position of the expandable tubular member 755 will vary as a function of the amount of radial expansion, the amount of axial shrinkage during radial expansion, and the material properties of the expandable tubular member.

As illustrated in Fig. 7c, a fluidic material 770 may then be injected through the apparatus 700 through the passages 710, 720, and 745 in order to test the proper operation of these passages.

As illustrated in Fig. 7d, a hardenable fluidic sealing material 775 may then be injected through the apparatus 700 through the passages 710, 720 and 745 into the annulus between the apparatus and the wellbore 10. In this manner, an annular barrier to fluid migration into and out of the wellbore 10 may be formed around the radially expanded expansion cone launcher 735 and expandable tubular member 755. The hardenable fluidic sealing material may include, for example, a cement mixture. In several alternative embodiments, the injection of the hardenable fluidic sealing material 775 may be omitted. In several alternative embodiments, the hardenable fluidic sealing material 775 is compressible, before, during and/or after, the curing process.

As illustrated in Fig. 7e, a non-hardenable fluidic material 780 may then be injected into the apparatus through the passages 710 and 720. A ball plug 785, or other similar device, may then be injected with the fluidic material 780 to thereby seal off the passage 745. In this manner, the region 750 may be pressurized by the continued injection of the fluidic material 780 into the apparatus 700.

As illustrated in Figs. 7f and 7g, the continued injection of the fluidic material 780 into the apparatus 700 causes the expansion cone launcher 735 and expandable tubular

member 755 to be plastically deformed and radially expanded off of the expansion cone 715. The resulting structure includes a lip 790.

After completing the plastic deformation and radial expansion of the tubular member 755, the hardenable fluidic sealing material is allowed to cure to thereby form an
5 annular body 795 that provides a barrier to fluid flow into or out of the wellbore 10.

Referring to Fig. 7h, the shoe 740 may then removed by drilling out the shoe using a conventional drilling device. A new section of the wellbore 10 may also be drilled out in order to permit additional expandable tubular members to be coupled to the bottom portion of the plastically deformed and radially expanded tubular member 755.

10 Referring to Fig. 7i, an additional tubular member 800 may then be plastically deformed and radially expanded in a conventional manner and/or by using one or more of the methods and apparatus described above in order to form a mono-diameter wellbore casing. Before, during or after the radial expansion of the tubular member 800, an annular
15 body 805 of a fluidic sealing material may be formed around the tubular member in a conventional manner and/or by using one or more of the methods and apparatus described above. In a preferred embodiment, the lip 790 facilitates the coupling of the tubular member 800 to the tubular member 755 by providing a region on which the tubular member 800 may be easily coupled onto.

Referring to Fig. 8a, in an alternative embodiment, a wellbore 10 includes a
20 preexisting section of wellbore casing 15 and 900. The wellbore casing 900 includes sealing members 905a and 905b and a recess 910. An annular body 915 of a fluidic sealing material may also be provided around the casing 900. The casing 900 and annular body 915 may be provided using any number of conventional methods, the methods described above, and/or using one or more of the methods disclosed in the following: (1)
25 U.S. patent application serial no. 09/454,139, attorney docket no. 25791.03.02, filed on 12/3/1999, (2) U.S. patent application serial no. 09/510,913, attorney docket no. 25791.7.02, filed on 2/23/2000, (3) U.S. patent application serial no. 09/502,350, attorney docket no. 25791.8.02, filed on 2/10/2000, (4) U.S. patent application serial no. 09/440,338, attorney docket no. 25791.9.02, filed on 11/15/1999, (5) U.S. patent
30 application serial no. 09/523,460, attorney docket no. 25791.11.02, filed on 3/10/2000, (6) U.S. patent application serial no. 09/512,895, attorney docket no. 25791.12.02, filed on 2/24/2000, (7) U.S. patent application serial no. 09/511,941, attorney docket no. 25791.16.02, filed on 2/24/2000, (8) U.S. patent application serial no. 09/588,946, attorney

docket no. 25791.17.02, filed on 6/7/2000, (9) U.S. patent application serial no. 09/559,122, attorney docket no. 25791.23.02, filed on 4/26/2000, (10) PCT patent application serial no. PCT/US00/18635, attorney docket no. 25791.25.02, filed on 7/9/2000, (11) U.S. provisional patent application serial no. 60/162,671, attorney docket
5 no. 25791.27, filed on 11/1/1999, (12) U.S. provisional patent application serial no. 60/154,047, attorney docket no. 25791.29, filed on 9/16/1999, (13) U.S. provisional patent application serial no. 60/159,082, attorney docket no. 25791.34, filed on 10/12/1999, (14) U.S. provisional patent application serial no. 60/159,039, attorney docket no. 25791.36, filed on 10/12/1999, (15) U.S. provisional patent application serial no. 60/159,033,
10 attorney docket no. 25791.37, filed on 10/12/1999, (16) U.S. provisional patent application serial no. _____, attorney docket no. 25791.38, filed on 6/19/2000, (17) U.S. provisional patent application serial no. 60/165,228, attorney docket no. 25791.39, filed on 11/12/1999, (18) U.S. provisional patent application serial no. _____, attorney docket no. 25791.45, filed on 7/28/2000, (19) U.S. provisional patent application serial no. _____,
15 _____, attorney docket no. 25791.46, filed on 7/28/2000, and (20) U.S. provisional patent application serial no. _____, attorney docket no. 25791.47, filed on 9/18/2000, the disclosures of which are incorporated herein by reference.

Referring to Fig. 8b, an apparatus 1000 for radially expanding a tubular member is then positioned within the wellbore 10 that includes a tubular support member 1005 that
20 defines a passage 1010 for conveying fluidic materials. A hydraulic locking device 1015 that defines a passage 1020 for conveying fluidic materials that is fluidically coupled to the passage 1010. The locking device 1015 further includes inlet passages, 1020a and 1020b, actuating chambers, 1025a and 1025b, and locking members, 1030a and 1030b. During operation, the injection of fluidic materials into the actuating chambers, 1025a and 1025b,
25 causes the locking members, 1030a and 1030b, to be displaced outwardly in the radial direction. In this manner, the locking device 1015 may be controllably coupled to a tubular member to thereby maintain the tubular member in a substantially stationary position. As will be recognized by persons having ordinary skill in the art, the operating pressures and physical shape of the inlet passages 1020, actuating chambers 1025, and
30 locking members 1030 will determine the maximum amount of holding force provided by the locking device 1015. In several alternative embodiments, fluidic materials may be injected into the locking device 1015 using a dedicated fluid passage in order to provide precise control of the locking device. In several alternative embodiments, the locking

device 1015 may be omitted and the tubular support member 1005 coupled directly to the tubular support member 1035.

One end of a tubular support member 1035 that defines a passage 1040 is coupled to the locking device 1015. The passage 1040 is fluidically coupled to the passage 1020.

5 An expansion cone 1045 that defines a passage 1050 and includes an outer conical surface 1055 is coupled to another end of the tubular support member 1035. An expansion cone launcher 1060 is movably coupled to and supported by the expansion cone 1045. The expansion cone launcher 1060 includes an upper portion 1060a having an upper outside diameter, an intermediate portion 1060b that mates with the expansion cone 1045, and a
10 lower portion 1060c having a lower outside diameter. The lower outside diameter is greater than the upper outside diameter.

A shoe 1065 that defines a valveable passage 1070 is coupled to the lower portion 1060c of the expansion cone launcher 1060. In this manner, a region 1075 below the expansion cone 1045 and bounded by the expansion cone launcher 1060 and the shoe 1065
15 may be pressurized and fluidically isolated from the annular region between the apparatus 1000 and the wellbore 10.

An expandable tubular member 1080 is coupled to the upper portion of the expansion cone launcher 1060. In several alternative embodiments, one or more sealing members are coupled to the exterior of the upper portion of the expandable tubular
20 member 1080. In several alternative embodiments, the sealing members may include elastomeric elements and/or metallic elements and/or composite elements. In several alternative embodiments, one or more anchoring elements may substituted for, or used in addition to, the sealing members.

An expansion cone 1085 defining a passage 1090 for receiving the tubular support
25 member 1005 includes an outer conical surface 1095. A tubular support member 1100 defining a passage 1105 for receiving the tubular support member 1005 is coupled to the bottom of the expansion cone 1085 for supporting and actuating the expansion cone.

In a preferred embodiment, the support members 1005 and 1035, the expansion cone 1045, the expansion cone launcher 1060, the shoe 1065, and the expandable tubular
30 member 1080 are provided substantially as disclosed in one or more of the following: (1) U.S. patent application serial no. 09/454,139, attorney docket no. 25791.03.02, filed on 12/3/1999, (2) U.S. patent application serial no. 09/510,913, attorney docket no. 25791.7.02, filed on 2/23/2000, (3) U.S. patent application serial no. 09/502,350, attorney

docket no. 25791.8.02, filed on 2/10/2000, (4) U.S. patent application serial no. 09/440,338, attorney docket no. 25791.9.02, filed on 11/15/1999, (5) U.S. patent application serial no. 09/523,460, attorney docket no. 25791.11.02, filed on 3/10/2000, (6) U.S. patent application serial no. 09/512,895, attorney docket no. 25791.12.02, filed on 5 2/24/2000, (7) U.S. patent application serial no. 09/511,941, attorney docket no. 25791.16.02, filed on 2/24/2000, (8) U.S. patent application serial no. 09/588,946, attorney docket no. 25791.17.02, filed on 6/7/2000, (9) U.S. patent application serial no. 09/559,122, attorney docket no. 25791.23.02, filed on 4/26/2000, (10) PCT patent application serial no. PCT/US00/18635, attorney docket no. 25791.25.02, filed on 10 7/9/2000, (11) U.S. provisional patent application serial no. 60/162,671, attorney docket no. 25791.27, filed on 11/1/1999, (12) U.S. provisional patent application serial no. 60/154,047, attorney docket no. 25791.29, filed on 9/16/1999, (13) U.S. provisional patent application serial no. 60/159,082, attorney docket no. 25791.34, filed on 10/12/1999, (14) U.S. provisional patent application serial no. 60/159,039, attorney docket no. 25791.36, 15 filed on 10/12/1999, (15) U.S. provisional patent application serial no. 60/159,033, attorney docket no. 25791.37, filed on 10/12/1999, (16) U.S. provisional patent application serial no. _____, attorney docket no. 25791.38, filed on 6/19/2000, (17) U.S. provisional patent application serial no. 60/165,228, attorney docket no. 25791.39, filed on 11/12/1999, (18) U.S. provisional patent application serial no. _____, attorney docket no. 25791.45, filed on 7/28/2000, (19) U.S. provisional patent application serial no. _____, attorney docket no. 25791.46, filed on 7/28/2000, and (20) U.S. 20 provisional patent application serial no. _____, attorney docket no. 25791.47, filed on 9/18/2000, the disclosures of which are incorporated herein by reference.

As illustrated in Fig. 8b, in a preferred embodiment, during placement of the 25 apparatus 1000 within the wellbore 10, fluidic materials 1110 within the wellbore 10 are conveyed through the apparatus 1000 through the passages 1010, 1020, 1040 and 1070 to a location above the apparatus 1000. In this manner, surge pressures during placement of the apparatus 1000 within the wellbore 10 are reduced. In a preferred embodiment, the apparatus 1000 is initially positioned within the wellbore 10 such that the top portion of 30 the tubular member 1080 overlaps with the recess 910 of the preexisting casing 900. In this manner, the upper portion of the expandable tubular member 1080 may be radially expanded into contact with and coupled to the recess 910 of the preexisting casing 900.

As illustrated in Fig. 8c, a fluidic material 1115 may then be injected through the apparatus 1000 through the passages 1010, 1020, 1040, and 1070 in order to test the proper operation of these passages.

As illustrated in Fig. 8d, a hardenable fluidic sealing material 1120 may then be injected through the apparatus 1000 through the passages 1010, 1020, 1040, and 1070 into the annulus between the apparatus and the wellbore 10. In this manner, an annular barrier to fluid migration into and out of the wellbore 10 may be formed around the radially expanded expansion cone launcher 1060 and expandable tubular member 1080. The hardenable fluidic sealing material may include, for example, a cement mixture. In several alternative embodiments, the injection of the hardenable fluidic sealing material 1120 may be omitted. In several alternative embodiments, the hardenable fluidic sealing material 1120 is compressible, before, during and/or after, the curing process.

As illustrated in Fig. 8e, a non-hardenable fluidic material 1125 may then be injected into the apparatus 1000 through the passages 1010, 1020 and 1040. A ball plug 1130, or other similar device, may then be injected with the fluidic material 1125 to thereby seal off the passage 1070. In this manner, the region 1075 may be pressurized by the continued injection of the fluidic material 1125 into the apparatus 1000. Furthermore, in this manner, the actuating chambers, 1025a and 1025b, of the locking device 1015 may be pressurized. In this manner, the tubular member 1080 may be held in a substantially stationary position by the locking device 1015.

As illustrated in Fig. 8f, the expansion cone 1085 may then be actuated in the downward direction by a direct application of axial force using the support member 1100 and/or through the application of fluid force. The axial displacement of the expansion cone 1085 may plastically deform and radially expand the upper portion of the expandable tubular member 1080. In this manner, the upper portion of the expandable tubular member 1080 may be precisely coupled to the recess 910 of the preexisting casing 900.

During the downward actuation of the expansion cone 1085, the locking member 1015 preferably prevents axial displacement of the tubular member 1080. In a preferred embodiment, the locking member 1015 is positioned proximate the upper portion of the tubular member 1080 in order to prevent buckling of the tubular member 1080 during the radial expansion of the upper portion of the tubular member. In an alternative embodiment, the locking member 1015 is omitted and the interference between the intermediate portion 1060b of the expansion cone launcher 1060 and the expansion cone

1045 prevents the axial displacement of the tubular member 1080 during the radial expansion of the upper portion of the tubular member.

As illustrated in Fig. 8g, the expansion cone 1085 and 1100 may then be raised out of the wellbore 10.

5 As illustrated in Fig. 8h, the continued injection of the fluidic material 1125 into the apparatus 1000 may then cause the expansion cone launcher 1060 and the expandable tubular member 1080 to be plastically deformed and radially expanded off of the expansion cone 1045. In this manner, the expansion cone 1045 is displaced relative to the expansion cone launcher 1060 and expandable tubular member 1080 in the axial direction.

10 In a preferred embodiment, the axial forces created during the radial expansion process are greater than the axial forces generated by the locking device 1015. As will be recognized by persons having ordinary skill in the art, the precise relationship between these axial forces will vary as a function of the operating characteristics of the locking device 1015 and the metallurgical properties of the expansion cone launcher 1060 and expandable

15 tubular 1080. In an alternative embodiment, the operating pressures of the actuating chambers, 1025a and 1025b, and the region 1075 are separately controllable by providing separate and dedicated fluid passages for pressurizing each.

As illustrated in Fig. 8i, after completing the plastic deformation and radial expansion of the tubular member 1080, the hardenable fluidic sealing material is allowed

20 to cure to thereby form an annular body 1130 that provides a barrier to fluid flow into or out of the wellbore 10. The shoe 1065 may then removed by drilling out the shoe using a conventional drilling device. A new section of the wellbore 10 may also be drilled out in order to permit additional expandable tubular members to be coupled to the bottom portion of the plastically deformed and radially expanded tubular member 1080.

25 In an alternative embodiment, the annular body 1130 may be omitted. In several alternative embodiments, the annular body 1130 may be radially compressed before, during and/or after curing.

Referring to Fig. 8j, the tubular member 1080 may be radially expanded again using one or more of the methods described above to provide an mono-diameter wellbore

30 casing.

Referring to Fig. 9a, a wellbore 1200 includes an upper preexisting casing 1205 and a lower preexisting casing 1210. The casings, 1205 and 1210, may further include

outer annular layers of fluidic sealing materials such as, for example, cement. The ends of the casings, 1205 and 1210, are separated by a gap 1215.

Referring to Fig. 9b, a tubular member 1220 may then be coupled to the opposing ends of the casings, 1205 and 1210, to thereby bridge the gap 1215. In a preferred embodiment, the tubular member 1220 is coupled to the opposing ends of the casings, 1205 and 1210, by plastically deforming and radially expanding the tubular member 1220 using one or more of the methods and apparatus described and referenced above.

Referring to Fig. 9c, a radial expansion device 1225 may then be positioned within the tubular member 1220. In a preferred embodiment, the length of the radial expansion device 1225 is greater than or equal to the axial length of the tubular member 1220. In several alternative embodiments, the radial expansion device 1225 may be any number of conventional radial expansion devices such as, for example, expansion cones actuated by hydraulic and/or direct axial force, roller expansion devices, and/or expandable hydraulic bladders.

Referring to Figs. 9d and 9e, after actuation and subsequent de-actuation and removal of the radial expansion device 1225, the inside diameters of the casings, 1205 and 1210, are substantially equal to the inside diameter of the tubular member 1220. In this manner, a mono-diameter wellbore casing may be formed.

Referring to Fig. 10, a wellbore 1300 includes an outer tubular member 1305 and an inner tubular member 1310. In a preferred embodiment, the tubular members, 1305 and 1310, are plastically deformed and radially expanded using one or more of the methods and apparatus described and referenced above. In this manner, a wellbore casing may be provided whose burst and collapse strength may be precisely controlled by varying the number, thickness, and/or material properties of the tubular members, 1305 and 1310.

Referring to Fig. 11a, a wellbore 1400 includes a casing 1405 that is coupled to a preexisting casing 1410. In a preferred embodiment, one or more sealing members 1415 are coupled to the exterior of the upper portion of the tubular member 1405 in order to optimally seal the interface between the tubular member 1405 and the preexisting casing 1410. In a preferred embodiment, the tubular member 1405 is plastically deformed and radially expanded using conventional methods and/or one or more of the methods and apparatus described and referenced above. In an exemplary embodiment, the outside diameter of the tubular member 1405 prior to the radial expansion process is OD_0 , the wall thickness of the tubular member 1405 prior to the radial expansion process is t_0 , the

outside diameter of the tubular member following the radial expansion process is OD_1 , and the wall thickness of the tubular member following the radial expansion process is t_1 .

Referring to Fig. 11b, a tubular member 1420 may then be coupled to the lower portion of the tubular member 1405 by plastically deforming and radially expanding the tubular member 1420 using conventional methods and/or one or more of the methods and apparatus described and referenced above. In a preferred embodiment, the exterior surface of the upper portion of the tubular member 1420 includes one or more sealing members for sealing the interface between the tubular member 1420 and the tubular member 1405.

Referring to Fig. 11c, lower portion of the tubular member 1405 and the tubular member 1420 may be radially expanded again to provide a mono-diameter wellbore casing. The additional radial expansion may be provided using conventional methods and/or one or more of the methods and apparatus described and referenced above. In an exemplary embodiment, the outside diameter and wall thickness of the lower portion of the tubular member 1405 after the additional radial expansion process are OD_2 and t_2 .

The radial expansion process of Figs. 11b-11c can then be repeated to provide a mono-diameter wellbore casing of virtually unlimited length.

In several alternative embodiments, the ordering of the radial expansions of the tubular members, 1405 and 1420, may be changed. For example, the first tubular member 1405 may be plastically deformed and radially expanded to provide a lower portion having the outside diameter OD_2 and the remaining portion having the outside diameter OD_1 . The tubular member 1420 may then be plastically deformed and radially expanded one or more times until the inside diameters of the tubular members, 1405 and 1420, are substantially equal. The plastic deformations and radial expansions of the tubular members, 1405 and 1420, may be provided using conventional methods and/or one or more of the methods and apparatus described and referenced above.

In an exemplary embodiment, the total expansion strain E of the tubular member 1405 may be expressed by the following equation:

$$E = (OD_2 - OD_0) / OD_0 \quad (1)$$

where OD_0 = original outside diameter;

OD_1 = outside diameter after 1st radial expansion; and

OD_2 = outside diameter after 2nd radial expansion.

Furthermore, in an exemplary embodiment, where: (1) the exterior surface of the upper portion of the tubular member 1420 includes sealing members, and (2) the radial spacing between the tubular member 1405 and the wellbore 1400 prior to the first radial expansion is equal to d , the outside diameters, OD_1 and OD_2 , of the tubular member 1405 following the first and second radial expansions may be expressed as:

$$OD_1 = OD_0 + 2d + 2t_1 \quad (2)$$

$$OD_2 = OD_1 + 2R + 2t_2 \quad (3)$$

where OD_0 = the original outside diameter of the tubular member 1405;
 OD_1 = the outside diameter of the tubular member 1405 following the first radial expansion;
 10 OD_2 = the outside diameter of the tubular member 1405 following the second radial expansion;
 d = the radial spacing between the tubular member 1405 and the wellbore prior to the first radial expansion;
 t_1 = the wall thickness of the tubular member 1405 after
 15 the first radial expansion;
 t_2 = the wall thickness of the tubular member 1405 after the second radial expansion; and
 R = the thickness of sealing member provided on the exterior surface of the tubular member 1420.

20 Furthermore, in an exemplary embodiment, for d approximately equal to 0.25 inches and R approximately equal to 0.1 inches, equation (1) can be approximated as:

$$E = (0.7'' + 3.7t_0) / OD_0 \quad (4)$$

where t_0 = the original wall thickness of the tubular member 1405.

25 In an exemplary embodiment, the total expansion strain of the tubular member 1405 should be less than or equal to 0.3 in order to maximize the burst and collapse strength of the expandable tubular member. Therefore, from equation (4) the ratio of the original outside diameter to the original wall thickness (OD_0/t_0) may be expressed as:

$$OD_0 / t_0 \geq 3.8 / (0.3 - 0.7 / OD_0) \quad (5)$$

Thus, in a preferred embodiment, for OD_0 less than 10 inches, the optimal ratio of the original outside diameter to the original wall thickness (OD_0/t_0) may be expressed as:

$$OD_0 / t_0 \geq 16 \quad (6)$$

In this manner, for typical tubular members, the burst and collapse strength of the
5 tubular members following one or more radial expansions are maximized when the
relationship in equation (6) is satisfied. Furthermore, the relationships expressed in
equations (1) through (6) are valid regardless of the order or type of the radial expansions
of the tubular member 1405. More generally, the relationships expressed in equations (1)
through (6) may be applied to the radial expansion of structures having a wide range of
10 profiles such as, for example, triangular, rectangular, and oval.

An apparatus for plastically deforming and radially expanding a tubular member
has been described that includes means for plastically deforming and radially expanding a
first portion of the tubular member to a first outside diameter, and means for plastically
deforming and radially expanding a second portion of the tubular member to a second
15 outside diameter. In a preferred embodiment, the first outside diameter is greater than the
second outside diameter. In a preferred embodiment, the means for plastically deforming
and radially expanding the first portion of the tubular member to the first outside diameter
is removable. In a preferred embodiment, the means for plastically deforming and radially
expanding the first portion of the tubular member to the first outside diameter is frangible.
20 In a preferred embodiment, the means for plastically deforming and radially expanding the
first portion of the tubular member to the first outside diameter is elastic. In a preferred
embodiment, the means for plastically deforming and radially expanding the first portion
of the tubular member to the first outside diameter includes means for applying a radial
force to the first portion of the tubular member. In a preferred embodiment, the means for
25 plastically deforming and radially expanding the first portion of the tubular member to the
first outside diameter is inflatable. In a preferred embodiment, the means for plastically
deforming and radially expanding the first portion of the tubular member to the first
outside diameter includes rolling means for applying radial pressure to the first portion of
the tubular member.

30 An apparatus for plastically deforming and radially expanding a tubular member
has also been described that includes a tubular support member including a first fluid
passage, an expansion cone coupled to the tubular support member having a second fluid
passage fluidically coupled to the first fluid passage and an outer conical surface, a

removable annular conical sleeve coupled to the outer conical surface of the expansion cone, an annular expansion cone launcher coupled to the conical sleeve and a lower portion of the tubular member, and a shoe having a valveable passage coupled to an end of the expansion cone launcher. In a preferred embodiment, the conical sleeve is frangible.

- 5 In a preferred embodiment, the conical sleeve is elastic. In a preferred embodiment, the conical sleeve includes a plurality of arcuate elements.

A method of plastically deforming and radially expanding a tubular member has also been described that includes plastically deforming and radially expanding a portion of the tubular member to a first outside diameter, and plastically deforming and radially
10 expanding another portion of the tubular member to a second outside diameter. In a preferred embodiment, the first diameter is greater than the second diameter. In a preferred embodiment, plastically deforming and radially expanding the portion of the tubular member includes applying a radial force to the portion of the tubular member using
15 a conical sleeve. In a preferred embodiment, conical sleeve is frangible. In a preferred embodiment, the conical sleeve is elastic. In a preferred embodiment, the conical sleeve includes a plurality of arcuate elements. In a preferred embodiment, plastically deforming and radially expanding the portion of the tubular member includes applying a radial force to the portion of the tubular member using an inflatable bladder. In a preferred
20 embodiment, plastically deforming and radially expanding the portion of the tubular member includes applying a radial force to the portion of the tubular member using a roller expansion device.

A method of coupling a first tubular member to a second tubular member has also been described that includes plastically deforming and radially expanding a first portion of the first tubular member to a first outside diameter, plastically deforming and radially
25 expanding another portion of the first tubular member to a second outside diameter, positioning the second tubular member inside the first tubular member in overlapping relation to the first portion of the first tubular member, plastically deforming and radially expanding the second tubular member to a third outside diameter, and plastically deforming and radially expanding the second tubular member to a fourth outside diameter.
30 The inside diameters of the first and second tubular members after the plastic deformations and radial expansions are substantially equal. In a preferred embodiment, the first outside diameter is greater than the second outside diameter. In a preferred embodiment, plastically deforming and radially expanding the first portion of the first tubular member

includes applying a radial force to the portion of the tubular member using a conical sleeve. In a preferred embodiment, the conical sleeve is frangible. In a preferred embodiment, the conical sleeve is elastic. In a preferred embodiment, the conical sleeve includes a plurality of arcuate elements. In a preferred embodiment, plastically deforming and radially expanding the first portion of the first tubular member includes applying a radial force to the first portion of the first tubular member using an inflatable bladder. In a preferred embodiment, plastically deforming and radially expanding the first portion of the first tubular member includes applying a radial force to the first portion of the first tubular member using a roller expansion device.

10 An apparatus for coupling a first tubular member to a second tubular member has also been described that includes means for plastically deforming and radially expanding a first portion of the first tubular member to a first outside diameter, means for plastically deforming and radially expanding another portion of the first tubular member to a second outside diameter, means for positioning the second tubular member inside the first tubular member in overlapping relation to the first portion of the first tubular member, means for plastically deforming and radially expanding the second tubular member to a third outside diameter, and means for plastically deforming and radially expanding the second tubular member to a fourth outside diameter. The inside diameters of the first and second tubular members after the plastic deformations and radial expansions are substantially equal. In a preferred embodiment, the first outside diameter is greater than the second outside diameter. In a preferred embodiment, the means for plastically deforming and radially expanding the first portion of the first tubular member includes means for applying a radial force to the portion of the tubular member using a conical sleeve. In a preferred embodiment, the conical sleeve is frangible. In a preferred embodiment, the conical sleeve is elastic. In a preferred embodiment, the conical sleeve includes a plurality of arcuate elements. In a preferred embodiment, the means for plastically deforming and radially expanding the first portion of the first tubular member includes means for applying a radial force to the first portion of the first tubular member using an inflatable bladder. In a preferred embodiment, the means for plastically deforming and radially expanding the first portion of the first tubular member includes means for applying a radial force to the first portion of the first tubular member using a roller expansion device.

An apparatus for forming a wellbore casing within a wellbore has also been described that includes means for supporting a tubular member within the wellbore, means

for plastically deforming and radially expanding a first portion of the tubular member to a first outside diameter, and means for plastically deforming and radially expanding a second portion of the tubular member to a second outside diameter. In a preferred embodiment, the first outside diameter is greater than the second outside diameter. In a preferred embodiment, the means for plastically deforming and radially expanding the first portion of the tubular member to the first outside diameter is removable. In a preferred embodiment, the means for plastically deforming and radially expanding the first portion of the tubular member to the first outside diameter is frangible. In a preferred embodiment, the means for plastically deforming and radially expanding the first portion of the tubular member to the first outside diameter is elastic. In a preferred embodiment, the means for plastically deforming and radially expanding the first portion of the tubular member to the first outside diameter includes means for applying a radial force to the first portion of the tubular member. In a preferred embodiment, the means for plastically deforming and radially expanding the first portion of the tubular member to the first outside diameter is inflatable. In a preferred embodiment, the means for plastically deforming and radially expanding the first portion of the tubular member to the first outside diameter includes rolling means for applying radial pressure to the first portion of the tubular member. In a preferred embodiment, the apparatus further includes means for forming an annular body of a fluidic sealing material within an annulus between the tubular member and the wellbore.

An apparatus for forming a wellbore casing within a wellbore has also been described that includes a tubular support member including a first fluid passage, an expansion cone coupled to the tubular support member having a second fluid passage fluidically coupled to the first fluid passage and an outer conical surface, a removable annular conical sleeve coupled to the outer conical surface of the expansion cone, an annular expansion cone launcher coupled to the conical sleeve and a lower portion of the tubular member, and a shoe having a valveable passage coupled to an end of the expansion cone launcher. In a preferred embodiment, the conical sleeve is frangible. In a preferred embodiment, the conical sleeve is elastic. In a preferred embodiment, the conical sleeve includes a plurality of arcuate elements.

A method of forming a wellbore casing within a wellbore has also been described that includes supporting a tubular member within a wellbore, plastically deforming and radially expanding a portion of the tubular member to a first outside diameter, and

plastically deforming and radially expanding another portion of the tubular member to a second outside diameter. In a preferred embodiment, the first diameter is greater than the second diameter. In a preferred embodiment, plastically deforming and radially expanding the portion of the tubular member includes applying a radial force to the portion of the tubular member using a conical sleeve. In a preferred embodiment, the conical sleeve is frangible. In a preferred embodiment, the conical sleeve is elastic. In a preferred embodiment, the conical sleeve includes a plurality of arcuate elements. In a preferred embodiment, plastically deforming and radially expanding the portion of the tubular member includes applying a radial force to the portion of the tubular member using an inflatable bladder. In a preferred embodiment, plastically deforming and radially expanding the portion of the tubular member includes applying a radial force to the portion of the tubular member using a roller expansion device. In a preferred embodiment, the method further includes injecting an annular body of a hardenable fluidic sealing material into an annulus between the tubular member and the wellbore. In a preferred embodiment, the method further includes curing the annular body of hardenable fluidic sealing material.

A method of forming a mono-diameter wellbore casing within a wellbore has also been described that includes supporting a first tubular member within the wellbore, plastically deforming and radially expanding a first portion of the first tubular member to a first outside diameter, plastically deforming and radially expanding another portion of the first tubular member to a second outside diameter, positioning the second tubular member inside the first tubular member in overlapping relation to the first portion of the first tubular member, plastically deforming and radially expanding the second tubular member to a third outside diameter, and plastically deforming and radially expanding the second tubular member to a fourth outside diameter. The inside diameters of the first and second tubular members after the plastic deformations and radial expansions are substantially equal. In a preferred embodiment, the first outside diameter is greater than the second outside diameter. In a preferred embodiment, plastically deforming and radially expanding the first portion of the first tubular member includes applying a radial force to the portion of the tubular member using a conical sleeve. In a preferred embodiment, the conical sleeve is frangible. In a preferred embodiment, the conical sleeve is elastic. In a preferred embodiment, the conical sleeve includes a plurality of arcuate elements. In a preferred embodiment, plastically deforming and radially expanding the first portion of the first tubular member includes applying a radial force to the first portion of the first tubular

member using an inflatable bladder. In a preferred embodiment, plastically deforming and radially expanding the first portion of the first tubular member includes applying a radial force to the first portion of the first tubular member using a roller expansion device. In a preferred embodiment, the method further includes injecting an annular body of a

5 hardenable fluidic sealing material into an annulus between the first tubular member and the wellbore. In a preferred embodiment, the method further includes curing the annular body of hardenable fluidic sealing material. In a preferred embodiment, the method further includes injecting an annular body of a hardenable fluidic sealing material into an annulus between the second tubular member and the wellbore. In a preferred embodiment,

10 the method further includes curing the annular body of hardenable fluidic sealing material.

An apparatus for coupling a first tubular member to a second tubular member has also been described that includes means for plastically deforming and radially expanding a first portion of the first tubular member to a first outside diameter, means for plastically deforming and radially expanding another portion of the first tubular member to a second

15 outside diameter, means for positioning the second tubular member inside the first tubular member in overlapping relation to the first portion of the first tubular member, means for plastically deforming and radially expanding the second tubular member to a third outside diameter, and means for plastically deforming and radially expanding the second tubular member to a fourth outside diameter. The inside diameters of the first and second tubular

20 members after the plastic deformations and radial expansions are substantially equal. In a preferred embodiment, the first outside diameter is greater than the second outside diameter. In a preferred embodiment, the means for plastically deforming and radially expanding the first portion of the first tubular member includes means for applying a radial force to the portion of the tubular member using a conical sleeve. In a preferred

25 embodiment, the conical sleeve is frangible. In a preferred embodiment, the conical sleeve is elastic. In a preferred embodiment, the conical sleeve includes a plurality of arcuate elements. In a preferred embodiment, the means for plastically deforming and radially expanding the first portion of the first tubular member includes means for applying a radial force to the first portion of the first tubular member using an inflatable bladder. In a

30 preferred embodiment, the means for plastically deforming and radially expanding the first portion of the first tubular member includes means for applying a radial force to the first portion of the first tubular member using a roller expansion device. In a preferred embodiment, the apparatus further includes means for injecting an annular body of a

hardenable fluidic sealing material into an annulus between the first tubular member and the wellbore. In a preferred embodiment, the apparatus further includes means for curing the annular body of hardenable fluidic sealing material. In a preferred embodiment, the apparatus further includes means for injecting an annular body of a hardenable fluidic
5 sealing material into an annulus between the second tubular member and the wellbore. In a preferred embodiment, the apparatus further includes means for curing the annular body of hardenable fluidic sealing material.

An apparatus for plastically deforming and radially expanding a tubular member has also been described that includes means for providing a lipped portion in a portion of
10 the tubular member, and means for plastically deforming and radially expanding another portion of the tubular member.

An apparatus for plastically deforming and radially expanding a tubular member has also been described that includes a tubular support member including a first fluid passage, an expansion cone coupled to the tubular support member having a second fluid
15 passage fluidically coupled to the first fluid passage and an outer conical surface, an annular expansion cone launcher including: a first annular portion coupled to a lower portion of the tubular member, a second annular portion coupled to the first annular portion that mates with the outer conical surface of the expansion cone, a third annular portion coupled to the second annular portion having a first outside diameter, and a fourth annular portion
20 coupled to the third annular portion having a second outside diameter, wherein the second outside diameter is less than the first outside diameter, and a shoe having a valveable passage coupled to fourth annular portion of the expansion cone launcher.

A method of plastically deforming and radially expanding a tubular member has also been described that includes providing a lipped portion in a portion of the tubular
25 member, and plastically deforming and radially expanding another portion of the tubular member.

A method of coupling a first tubular member to a second tubular member has also been described that includes providing a lipped portion in a portion of the first tubular member, plastically deforming and radially expanding another portion of the first tubular
30 member, positioning the second tubular member inside the first tubular member in overlapping relation to the lipped portion of the first tubular member, and plastically deforming and radially expanding the second tubular member. The inside diameters of the

first and second tubular members after the plastic deformations and radial expansions are substantially equal.

An apparatus for coupling a first tubular member to a second tubular member has also been described that includes means for providing a lipped in the first tubular member, 5 means for plastically deforming and radially expanding another portion of the first tubular member, means for positioning the second tubular member inside the first tubular member in overlapping relation to the lipped portion of the first tubular member, and means for plastically deforming and radially expanding the second tubular member. The inside 10 diameters of the first and second tubular members after the plastic deformations and radial expansions are substantially equal.

An apparatus for forming a wellbore casing within a wellbore has also been described that includes means for supporting a tubular member within the wellbore, means for providing a lipped portion in the tubular member, and means for plastically deforming and radially expanding another portion of the tubular member to a second outside 15 diameter.

An apparatus for forming a wellbore casing within a wellbore has also been described that includes a tubular support member including a first fluid passage, an expansion cone coupled to the tubular support member having a second fluid passage fluidically coupled to the first fluid passage and an outer conical surface, an annular 20 expansion cone launcher including: a first annular portion coupled to a lower portion of the tubular member, a second annular portion coupled to the first annular portion that mates with the outer conical surface of the expansion cone, a third annular portion coupled to the second annular portion having a first outside diameter, and a fourth annular portion coupled to the third annular portion having a second outside diameter, wherein the second 25 outside diameter is less than the first outside diameter, and a shoe having a valveable passage coupled to fourth annular portion of the expansion cone launcher.

A method of forming a wellbore casing in a wellbore has also been described that includes supporting a tubular member within the wellbore, providing a lipped portion in a portion of the tubular member, and plastically deforming and radially expanding another 30 portion of the tubular member. In a preferred embodiment, the method further includes injecting a hardenable fluidic sealing material in an annulus between the tubular member and the wellbore. In a preferred embodiment, the method further includes curing the fluidic sealing material.

A method of forming a mono-diameter wellbore casing within a wellbore has also been described that includes supporting a first tubular member within the wellbore, providing a lipped portion in a portion of the first tubular member, plastically deforming and radially expanding another portion of the first tubular member, positioning the second tubular member inside the first tubular member in overlapping relation to the lipped portion of the first tubular member, and plastically deforming and radially expanding the second tubular member. The inside diameters of the first and second tubular members after the plastic deformations and radial expansions are substantially equal. In a preferred embodiment, the method further includes injecting a hardenable fluidic sealing material in an annulus between the first tubular member and the wellbore. In a preferred embodiment, the method further includes curing the fluidic sealing material. In a preferred embodiment, the method further includes injecting a hardenable fluidic sealing material in an annulus between the second tubular member and the wellbore. In a preferred embodiment, the method further includes curing the fluidic sealing material.

An apparatus for forming a mono-diameter wellbore casing within a wellbore has also been described that includes means for providing a lipped in the first tubular member, means for plastically deforming and radially expanding another portion of the first tubular member, means for positioning the second tubular member inside the first tubular member in overlapping relation to the lipped portion of the first tubular member, and means for plastically deforming and radially expanding the second tubular member. The inside diameters of the first and second tubular members after the plastic deformations and radial expansions are substantially equal. In a preferred embodiment, the apparatus further includes means for injecting a hardenable fluidic sealing material in an annulus between the first tubular member and the wellbore. In a preferred embodiment, the apparatus further includes means for curing the fluidic sealing material. In a preferred embodiment, the apparatus further includes means for injecting a hardenable fluidic sealing material in an annulus between the second tubular member and the wellbore. In a preferred embodiment, the apparatus further includes means for curing the fluidic sealing material.

An apparatus for plastically deforming and radially expanding a tubular member has also been described that includes means for plastically deforming and radially expanding a first end of the tubular member, and means for plastically deforming and radially expanding a second end of the tubular member. In a preferred embodiment, the

apparatus further includes means for anchoring the tubular member during the radial expansion.

An apparatus for plastically deforming and radially expanding a tubular member has also been described that includes a tubular support member including a first passage, 5 an expansion cone coupled to the tubular support having a second passage fluidically coupled to the first passage and an outer conical surface, an annular expansion cone launcher movably coupled to outer conical surface of the expansion cone, an expandable tubular member coupled to an end of the annular expansion cone launcher, a shoe coupled to another end of the annular expansion cone launcher having a valveable fluid passage, 10 and another annular expansion cone movably coupled to the tubular support member. The annular expansion cones are positioned in opposite orientations. In a preferred embodiment, the annular expansion cone is adapted to plastically deform and radially expand a first end of the expandable tubular member and the other annular expansion cone is adapted to plastically deform and radially expand a second end of the expandable 15 tubular member. In a preferred embodiment, the apparatus further includes an anchoring member coupled to the tubular support member adapted to hold the expandable tubular.

A method of plastically deforming and radially expanding a tubular member has also been described that includes plastically deforming and radially expanding a first end of the tubular member, and plastically deforming and radially expanding a second end of 20 the tubular member. In a preferred embodiment, the method further includes anchoring the tubular member during the radial expansion. In a preferred embodiment, the first end of the tubular member is plastically deformed and radially expanded before the second end. In a preferred embodiment, plastically deforming and radially expanding the second end of the tubular member includes injecting a fluidic material into the tubular member.

25 A method of coupling a first tubular member to a second tubular member has also been described that includes positioning the second tubular member inside the first tubular member in an overlapping relationship, plastically deforming and radially expanding the end of the second tubular member that overlaps with the first tubular member, and plastically deforming and radially expanding the remaining portion of the second tubular 30 member. In a preferred embodiment, the method further includes plastically deforming and radially expanding at least a portion of the second tubular member. In a preferred embodiment, the inside diameters of the first and second tubular members are substantially equal after the radial expansions.

An apparatus for coupling a first tubular member to a second tubular member has also been described that includes means for positioning the second tubular member inside the first tubular member in an overlapping relationship, means for plastically deforming and radially expanding the end of the second tubular member that overlaps with the first tubular member, and means for plastically deforming and radially expanding the remaining portion of the second tubular member. In a preferred embodiment, the apparatus further includes means for plastically deforming and radially expanding at least a portion of the second tubular member. In a preferred embodiment, the inside diameters of the first and second tubular members are substantially equal after the radial expansions.

10 An apparatus for forming a wellbore casing within a wellbore has also been described that includes means for supporting a tubular member within the wellbore, means for plastically deforming and radially expanding a first end of the tubular member, and means for plastically deforming and radially expanding a second end of the tubular member. In a preferred embodiment, the apparatus further includes means for anchoring the tubular member during the radial expansion. In a preferred embodiment, the apparatus further includes means for injecting a hardenable fluidic sealing material into an annulus between the tubular member and the wellbore.

20 An apparatus for forming a wellbore casing within a wellbore has also been described that includes a tubular support member including a first passage, an expansion cone coupled to the tubular support having a second passage fluidically coupled to the first passage and an outer conical surface, an annular expansion cone launcher movably coupled to outer conical surface of the expansion cone, an expandable tubular member coupled to an end of the annular expansion cone launcher, a shoe coupled to another end of the annular expansion cone launcher having a valveable fluid passage, and another annular expansion cone movably coupled to the tubular support member. The annular expansion cones are positioned in opposite orientations. In a preferred embodiment, the annular expansion cone is adapted to plastically deform and radially expand a first end of the expandable tubular member and the other annular expansion cone is adapted to plastically deform and radially expand a second end of the expandable tubular member. In a preferred embodiment, the apparatus further includes an anchoring member coupled to the tubular support member adapted to hold the expandable tubular.

A method of forming a wellbore casing within a wellbore has also been described that includes plastically deforming and radially expanding a first end of the tubular

member, and plastically deforming and radially expanding a second end of the tubular member. In a preferred embodiment, the method further includes anchoring the tubular member during the radial expansion. In a preferred embodiment, the first end of the tubular member is plastically deformed and radially expanded before the second end. In a preferred embodiment, plastically deforming and radially expanding the second end of the tubular member includes injecting a fluidic material into the tubular member. In a preferred embodiment, the method further includes injecting a hardenable fluidic sealing material into an annulus between the tubular member and the wellbore.

A method of forming a wellbore casing within a wellbore has also been described that includes plastically deforming and radially expanding a first tubular member within the wellbore, positioning a second tubular member inside the first tubular member in an overlapping relationship, plastically deforming and radially expanding the end of the second tubular member that overlaps with the first tubular member, plastically deforming and radially expanding the remaining portion of the second tubular member. In a preferred embodiment, the method further includes plastically deforming and radially expanding at least a portion of the second tubular member. In a preferred embodiment, the inside diameters of the first and second tubular members are substantially equal after the radial expansions. In a preferred embodiment, the method further includes injecting a hardenable fluidic sealing material into an annulus between the first tubular member and the wellbore. In a preferred embodiment, the method further includes injecting a hardenable fluidic sealing material into an annulus between the second tubular member and the wellbore.

An apparatus for forming a wellbore casing within a wellbore has also been described that includes means for plastically deforming and radially expanding a first tubular member within the wellbore, means for positioning the second tubular member inside the first tubular member in an overlapping relationship, means for plastically deforming and radially expanding the end of the second tubular member that overlaps with the first tubular member, means for plastically deforming and radially expanding the remaining portion of the second tubular member. In a preferred embodiment, the apparatus further includes means for plastically deforming and radially expanding at least a portion of the second tubular member. In a preferred embodiment, the inside diameters of the first and second tubular members are substantially equal after the radial expansions. In a preferred embodiment, the apparatus further includes means for injecting a hardenable fluidic sealing material into an annulus between the first tubular member and

the wellbore. In a preferred embodiment, the apparatus further includes means for injecting a hardenable fluidic sealing material into an annulus between the second tubular member and the wellbore.

5 An apparatus for bridging an axial gap between opposing pairs of wellbore casing within a wellbore has also been described that includes means for supporting a tubular member in overlapping relation to the opposing ends of the wellbore casings, means for plastically deforming and radially expanding the tubular member, and means for plastically deforming and radially expanding the tubular member and the opposing ends of the wellbore casings.

10 A method of bridging an axial gap between opposing pairs of wellbore casing within a wellbore has also been described that includes supporting a tubular member in overlapping relation to the opposing ends of the wellbore casings, plastically deforming and radially expanding the tubular member, and plastically deforming and radially expanding the tubular member and the opposing ends of
15 the wellbore casings.

A method of forming a structure having desired strength characteristics has also been described that includes providing a first tubular member, and plastically deforming and radially expanding additional tubular members onto the interior surface of the first tubular member until the desired strength characteristics are achieved.

20 A method of forming a wellbore casing within a wellbore having desired strength characteristics has also been described that includes plastically deforming and radially expanding a first tubular member within the wellbore, and plastically deforming and radially expanding additional tubular members onto the interior surface of the first tubular member until the desired strength characteristics are achieved.

25 A method of coupling a first tubular member to a second tubular member, the first tubular member having an original outside diameter OD_0 and an original wall thickness t_0 , has also been described that includes plastically deforming and radially expanding a first portion of the first tubular member to a first outside diameter, plastically deforming and radially expanding another portion of the first tubular member to a second outside
30 diameter, positioning the second tubular member inside the first tubular member in overlapping relation to the first portion of the first tubular member, plastically deforming and radially expanding the second tubular member to a third outside diameter, and plastically deforming and radially expanding the second tubular member to a fourth

outside diameter, wherein the inside diameters of the first and second tubular members after the plastic deformations and radial expansions are substantially equal, and wherein the ratio of the original outside diameter OD_0 of the first tubular member to the original wall thickness t_0 of the first tubular member is greater than or equal to 16.

5 A method of forming a mono-diameter wellbore casing has also been described that includes positioning a first tubular member within a wellbore, the first tubular member having an original outside diameter OD_0 and an original wall thickness t_0 , plastically deforming and radially expanding a first portion of the first tubular member to a first outside diameter, plastically deforming and radially expanding another portion of the first
10 tubular member to a second outside diameter, positioning the second tubular member inside the first tubular member in overlapping relation to the first portion of the first tubular member, plastically deforming and radially expanding the second tubular member to a third outside diameter, and plastically deforming and radially expanding the second tubular member to a fourth outside diameter. The inside diameters of the first and second
15 tubular members after the plastic deformations and radial expansions are substantially equal, and wherein the ratio of the original outside diameter OD_0 of the first tubular member to the original wall thickness t_0 of the first tubular member is greater than or equal to 16.

 An apparatus has also been described that includes a plastically deformed and
20 radially expanded tubular member having a first portion having a first outside diameter and a remaining portion having a second outside diameter, wherein the ratio of the original outside diameter OD_0 of the first tubular member to the original wall thickness t_0 of the first tubular member is greater than or equal to 16.

 An apparatus has also been described that includes a plastically deformed and
25 radially expanded first tubular member having a first portion having a first outside diameter and a remaining portion having a second outside diameter, and a plastically deformed and radially expanded second tubular member coupled to the first portion of the first tubular member. The ratio of the original outside diameter OD_0 of the first tubular member to the original wall thickness t_0 of the first tubular member is greater than or equal
30 to 16. In a preferred embodiment, the inside diameters of the first and second tubular members are substantially equal.

 A wellbore casing formed in a wellbore has also been described that includes a plastically deformed and radially expanded first tubular member having a first portion

having a first outside diameter and a remaining portion having a second outside diameter, and a plastically deformed and radially expanded second tubular member coupled to the first portion of the first tubular member. The ratio of the original outside diameter OD_0 of the first tubular member to the original wall thickness t_0 of the first tubular member is
5 greater than or equal to 16. In a preferred embodiment, the inside diameters of the first and second tubular members are substantially equal.

An apparatus has also been described that includes a plastically deformed and radially expanded tubular member. In a preferred embodiment, the ratio of the original outside diameter OD_0 of the tubular member to the original wall thickness t_0 of the tubular
10 member is greater than or equal to 16.

In several alternative embodiments, the methods and apparatus described and referenced above may be used to form or repair wellbore casings, pipelines, and structural supports.

Although this detailed description has shown and described illustrative
15 embodiments of the invention, this description contemplates a wide range of modifications, changes, and substitutions. In some instances, one may employ some features of the present invention without a corresponding use of the other features. Accordingly, it is appropriate that readers should construe the appended claims broadly, and in a manner consistent with the scope of the invention.

Claims

What is claimed is:

- 1 1. An apparatus for plastically deforming and radially expanding a tubular member,
2 comprising:
3 means for plastically deforming and radially expanding a first portion of the tubular
4 member to a first outside diameter; and
5 means for plastically deforming and radially expanding a second portion of the
6 tubular member to a second outside diameter.
- 1 2. The apparatus of claim 1, wherein the first outside diameter is greater than the
2 second outside diameter.
- 1 3. The apparatus of claim 1, wherein the means for plastically deforming and radially
2 expanding the first portion of the tubular member to the first outside diameter is
3 removable.
- 1 4. The apparatus of claim 1, wherein the means for plastically deforming and radially
2 expanding the first portion of the tubular member to the first outside diameter is frangible.
- 1 5. The apparatus of claim 1, wherein the means for plastically deforming and radially
2 expanding the first portion of the tubular member to the first outside diameter is elastic.
- 1 6. The apparatus of claim 1, wherein the means for plastically deforming and radially
2 expanding the first portion of the tubular member to the first outside diameter comprises
3 means for applying a radial force to the first portion of the tubular member.
- 1 7. The apparatus of claim 1, wherein the means for plastically deforming and radially
2 expanding the first portion of the tubular member to the first outside diameter is inflatable.
- 1 8. The apparatus of claim 1, wherein the means for plastically deforming and radially
2 expanding the first portion of the tubular member to the first outside diameter includes
3 rolling means for applying radial pressure to the first portion of the tubular member.

- 1 9. An apparatus for plastically deforming and radially expanding a tubular member,
2 comprising:
3 a tubular support member including a first fluid passage;
4 an expansion cone coupled to the tubular support member having a second fluid
5 passage fluidically coupled to the first fluid passage and an outer conical
6 surface;
7 a removable annular conical sleeve coupled to the outer conical surface of the
8 expansion cone;
9 an annular expansion cone launcher coupled to the conical sleeve and a lower
10 portion of the tubular member; and
11 a shoe having a valveable passage coupled to an end of the expansion cone
12 launcher.
- 1 10. The apparatus of claim 9, wherein the conical sleeve is frangible.
- 1 11. The apparatus of claim 9, wherein the conical sleeve is elastic.
- 1 12. The apparatus of claim 9, wherein the conical sleeve comprises a plurality of
2 arcuate elements.
- 1 13. A method of plastically deforming and radially expanding a tubular member,
2 comprising:
3 plastically deforming and radially expanding a portion of the tubular member to a
4 first outside diameter; and
5 plastically deforming and radially expanding another portion of the tubular member
6 to a second outside diameter.
- 1 14. The method of claim 13, wherein the first diameter is greater than the second
2 diameter.
- 1 15. The method of claim 13, wherein plastically deforming and radially expanding the
2 portion of the tubular member comprises:
3 applying a radial force to the portion of the tubular member using a conical sleeve.

- 1 16. The method of claim 15, wherein the conical sleeve is frangible.
- 1 17. The method of claim 15, wherein the conical sleeve is elastic.
- 1 18. The method of claim 15, wherein the conical sleeve comprises a plurality of
2 arcuate elements.
- 1 19. The method of claim 13, wherein plastically deforming and radially expanding the
2 portion of the tubular member comprises:
3 applying a radial force to the portion of the tubular member using an inflatable
4 bladder.
- 1 20. The method of claim 13, wherein plastically deforming and radially expanding the
2 portion of the tubular member comprises:
3 applying a radial force to the portion of the tubular member using a roller
4 expansion device.
- 1 21. A method of coupling a first tubular member to a second tubular member,
2 comprising:
3 plastically deforming and radially expanding a first portion of the first tubular
4 member to a first outside diameter;
5 plastically deforming and radially expanding another portion of the first tubular
6 member to a second outside diameter;
7 positioning the second tubular member inside the first tubular member in
8 overlapping relation to the first portion of the first tubular member;
9 plastically deforming and radially expanding the second tubular member to a third
10 outside diameter; and
11 plastically deforming and radially expanding the second tubular member to a fourth
12 outside diameter;
13 wherein the inside diameters of the first and second tubular members after the
14 plastic deformations and radial expansions are substantially equal.

- 1 22. The method of claim 21, wherein the first outside diameter is greater than the
2 second outside diameter.
- 1 23. The method of claim 21, wherein plastically deforming and radially expanding the
2 first portion of the first tubular member comprises:
3 applying a radial force to the portion of the tubular member using a conical sleeve.
- 1 24. The method of claim 23, wherein the conical sleeve is frangible.
- 1 25. The method of claim 23, wherein the conical sleeve is elastic.
- 1 26. The method of claim 23, wherein the conical sleeve comprises a plurality of
2 arcuate elements.
- 1 27. The method of claim 21, wherein plastically deforming and radially expanding the
2 first portion of the first tubular member comprises:
3 applying a radial force to the first portion of the first tubular member using an
4 inflatable bladder.
- 1 28. The method of claim 21, wherein plastically deforming and radially expanding the
2 first portion of the first tubular member comprises:
3 applying a radial force to the first portion of the first tubular member using a roller
4 expansion device.
- 1 29. An apparatus for coupling a first tubular member to a second tubular member,
2 comprising:
3 means for plastically deforming and radially expanding a first portion of the first
4 tubular member to a first outside diameter;
5 means for plastically deforming and radially expanding another portion of the first
6 tubular member to a second outside diameter;
7 means for positioning the second tubular member inside the first tubular member in
8 overlapping relation to the first portion of the first tubular member;

9 means for plastically deforming and radially expanding the second tubular member
10 to a third outside diameter; and
11 means for plastically deforming and radially expanding the second tubular member
12 to a fourth outside diameter;
13 wherein the inside diameters of the first and second tubular members after the
14 plastic deformations and radial expansions are substantially equal.

1 30. The apparatus of claim 29, wherein the first outside diameter is greater than the
2 second outside diameter.

1 31. The apparatus of claim 29, wherein the means for plastically deforming and
2 radially expanding the first portion of the first tubular member comprises:
3 means for applying a radial force to the portion of the tubular member using a
4 conical sleeve.

1 32. The apparatus of claim 31, wherein the conical sleeve is frangible.

1 33. The apparatus of claim 31, wherein the conical sleeve is elastic.

1 34. The apparatus of claim 31, wherein the conical sleeve comprises a plurality of
2 arcuate elements.

1 35. The apparatus of claim 29, wherein the means for plastically deforming and
2 radially expanding the first portion of the first tubular member comprises:
3 means for applying a radial force to the first portion of the first tubular member
4 using an inflatable bladder.

1 36. The apparatus of claim 29, wherein the means for plastically deforming and
2 radially expanding the first portion of the first tubular member comprises:
3 means for applying a radial force to the first portion of the first tubular member
4 using a roller expansion device.

1 37. An apparatus for forming a wellbore casing within a wellbore, comprising:
2 means for supporting a tubular member within the wellbore;
3 means for plastically deforming and radially expanding a first portion of the tubular
4 member to a first outside diameter; and
5 means for plastically deforming and radially expanding a second portion of the
6 tubular member to a second outside diameter.

1 38. The apparatus of claim 37, wherein the first outside diameter is greater than the
2 second outside diameter.

1 39. The apparatus of claim 37, wherein the means for plastically deforming and
2 radially expanding the first portion of the tubular member to the first outside diameter is
3 removable.

1 40. The apparatus of claim 37, wherein the means for plastically deforming and
2 radially expanding the first portion of the tubular member to the first outside diameter is
3 frangible.

1 41. The apparatus of claim 37, wherein the means for plastically deforming and
2 radially expanding the first portion of the tubular member to the first outside diameter is
3 elastic.

1 42. The apparatus of claim 37, wherein the means for plastically deforming and
2 radially expanding the first portion of the tubular member to the first outside diameter
3 comprises means for applying a radial force to the first portion of the tubular member.

1 43. The apparatus of claim 37, wherein the means for plastically deforming and
2 radially expanding the first portion of the tubular member to the first outside diameter is
3 inflatable.

1 44. The apparatus of claim 37, wherein the means for plastically deforming and
2 radially expanding the first portion of the tubular member to the first outside diameter

3 comprises rolling means for applying radial pressure to the first portion of the tubular
4 member.

1 45. The apparatus of claim 37, further comprising:
2 means for forming an annular body of a fluidic sealing material within an annulus
3 between the tubular member and the wellbore.

1 46. An apparatus for forming a wellbore casing within a wellbore, comprising:
2 a tubular support member including a first fluid passage;
3 an expansion cone coupled to the tubular support member having a second fluid
4 passage fluidically coupled to the first fluid passage and an outer conical
5 surface;
6 a removable annular conical sleeve coupled to the outer conical surface of the
7 expansion cone;
8 an annular expansion cone launcher coupled to the conical sleeve and a lower
9 portion of the tubular member; and
10 a shoe having a valveable passage coupled to an end of the expansion cone
11 launcher.

1 47. The apparatus of claim 46, wherein the conical sleeve is frangible.

1 48. The apparatus of claim 46, wherein the conical sleeve is elastic.

1 49. The apparatus of claim 46, wherein the conical sleeve comprises a plurality of
2 arcuate elements.

1 50. A method of forming a wellbore casing within a wellbore, comprising:
2 supporting a tubular member within a wellbore;
3 plastically deforming and radially expanding a portion of the tubular member to a
4 first outside diameter; and
5 plastically deforming and radially expanding another portion of the tubular member
6 to a second outside diameter.

- 1 51. The method of claim 50, wherein the first diameter is greater than the second
2 diameter.
- 1 52. The method of claim 50, wherein plastically deforming and radially expanding the
2 portion of the tubular member comprises:
3 applying a radial force to the portion of the tubular member using a conical sleeve.
- 1 53. The method of claim 50, wherein the conical sleeve is frangible.
- 1 54. The method of claim 50, wherein the conical sleeve is elastic.
- 1 55. The method of claim 50, wherein the conical sleeve comprises a plurality of
2 arcuate elements.
- 1 56. The method of claim 50, wherein plastically deforming and radially expanding the
2 portion of the tubular member comprises:
3 applying a radial force to the portion of the tubular member using an inflatable
4 bladder.
- 1 57. The method of claim 50, wherein plastically deforming and radially expanding the
2 portion of the tubular member comprises:
3 applying a radial force to the portion of the tubular member using a roller
4 expansion device.
- 1 58. The method of claim 50, further comprising:
2 injecting an annular body of a hardenable fluidic sealing material into an annulus
3 between the tubular member and the wellbore.
- 1 59. The method of claim 58, further comprising:
2 curing the annular body of hardenable fluidic sealing material.
- 1 60. A method of forming a mono-diameter wellbore casing within a wellbore,
2 comprising:

3 supporting a first tubular member within the wellbore;
4 plastically deforming and radially expanding a first portion of the first tubular
5 member to a first outside diameter;
6 plastically deforming and radially expanding another portion of the first tubular
7 member to a second outside diameter;
8 positioning the second tubular member inside the first tubular member in
9 overlapping relation to the first portion of the first tubular member;
10 plastically deforming and radially expanding the second tubular member to a third
11 outside diameter; and
12 plastically deforming and radially expanding the second tubular member to a fourth
13 outside diameter;
14 wherein the inside diameters of the first and second tubular members after the
15 plastic deformations and radial expansions are substantially equal.

1 61. The method of claim 60, wherein the first outside diameter is greater than the
2 second outside diameter.

1 62. The method of claim 60, wherein plastically deforming and radially expanding the
2 first portion of the first tubular member comprises:
3 applying a radial force to the portion of the tubular member using a conical sleeve.

1 63. The method of claim 62, wherein the conical sleeve is frangible.

1 64. The method of claim 62, wherein the conical sleeve is elastic.

1 65. The method of claim 62, wherein the conical sleeve comprises a plurality of
2 arcuate elements.

1 66. The method of claim 60, wherein plastically deforming and radially expanding the
2 first portion of the first tubular member comprises:
3 applying a radial force to the first portion of the first tubular member using an
4 inflatable bladder.

- 1 67. The method of claim 60, wherein plastically deforming and radially expanding the
2 first portion of the first tubular member comprises:
3 applying a radial force to the first portion of the first tubular member using a roller
4 expansion device.
- 1 68. The method of claim 60, further comprising:
2 injecting an annular body of a hardenable fluidic sealing material into an annulus
3 between the first tubular member and the wellbore.
- 1 69. The method of claim 68, further comprising:
2 curing the annular body of hardenable fluidic sealing material.
- 3 70. The method of claim 60, further comprising:
4 injecting an annular body of a hardenable fluidic sealing material into an annulus
5 between the second tubular member and the wellbore.
- 1 71. The method of claim 70, further comprising:
2 curing the annular body of hardenable fluidic sealing material.
- 1 72. An apparatus for coupling a first tubular member to a second tubular member,
2 comprising:
3 means for plastically deforming and radially expanding a first portion of the first
4 tubular member to a first outside diameter;
5 means for plastically deforming and radially expanding another portion of the first
6 tubular member to a second outside diameter;
7 means for positioning the second tubular member inside the first tubular member in
8 overlapping relation to the first portion of the first tubular member;
9 means for plastically deforming and radially expanding the second tubular member
10 to a third outside diameter; and
11 means for plastically deforming and radially expanding the second tubular member
12 to a fourth outside diameter;
13 wherein the inside diameters of the first and second tubular members after the
14 plastic deformations and radial expansions are substantially equal.

- 1 73. The apparatus of claim 72, wherein the first outside diameter is greater than the
2 second outside diameter.
- 1 74. The apparatus of claim 72, wherein the means for plastically deforming and
2 radially expanding the first portion of the first tubular member comprises:
3 means for applying a radial force to the portion of the tubular member using a
4 conical sleeve.
- 1 75. The apparatus of claim 74, wherein the conical sleeve is frangible.
- 1 76. The apparatus of claim 74, wherein the conical sleeve is elastic.
- 1 77. The apparatus of claim 74, wherein the conical sleeve comprises a plurality of
2 arcuate elements.
- 1 78. The apparatus of claim 72, wherein the means for plastically deforming and
2 radially expanding the first portion of the first tubular member comprises:
3 means for applying a radial force to the first portion of the first tubular member
4 using an inflatable bladder.
- 1 79. The apparatus of claim 72, wherein the means for plastically deforming and
2 radially expanding the first portion of the first tubular member comprises:
3 means for applying a radial force to the first portion of the first tubular member
4 using a roller expansion device.
- 1 80. The apparatus of claim 72, further comprising:
2 means for injecting an annular body of a hardenable fluidic sealing material into an
3 annulus between the first tubular member and the wellbore.
- 1 81. The apparatus of claim 80, further comprising:
2 means for curing the annular body of hardenable fluidic sealing material.

3 82. The apparatus of claim 72, further comprising:
4 means for injecting an annular body of a hardenable fluidic sealing material into an
5 annulus between the second tubular member and the wellbore.

1 83. The apparatus of claim 82, further comprising:
2 means for curing the annular body of hardenable fluidic sealing material.

- 1 84. An apparatus for plastically deforming and radially expanding a tubular member,
2 comprising:
3 means for providing a lipped portion in a portion of the tubular member; and
4 means for plastically deforming and radially expanding another portion of the
5 tubular member.
- 1 85. An apparatus for plastically deforming and radially expanding a tubular member,
2 comprising:
3 a tubular support member including a first fluid passage;
4 an expansion cone coupled to the tubular support member having a second fluid
5 passage fluidly coupled to the first fluid passage and an outer conical
6 surface;
7 an annular expansion cone launcher comprising:
8 a first annular portion coupled to a lower portion of the tubular member;
9 a second annular portion coupled to the first annular portion that mates with
10 the outer conical surface of the expansion cone;
11 a third annular portion coupled to the second annular portion having a first
12 outside diameter; and
13 a fourth annular portion coupled to the third annular portion having a
14 second outside diameter,
15 wherein the second outside diameter is less than the first outside diameter;
16 and
17 a shoe having a valveable passage coupled to fourth annular portion of the
18 expansion cone launcher.
- 1 86. A method of plastically deforming and radially expanding a tubular member,
2 comprising:
3 providing a lipped portion in a portion of the tubular member; and
4 plastically deforming and radially expanding another portion of the tubular
5 member.
- 1 87. A method of coupling a first tubular member to a second tubular member,
2 comprising:

3 providing a lipped portion in a portion of the first tubular member;
4 plastically deforming and radially expanding another portion of the first tubular
5 member;
6 positioning the second tubular member inside the first tubular member in
7 overlapping relation to the lipped portion of the first tubular member, and
8 plastically deforming and radially expanding the second tubular member;
9 wherein the inside diameters of the first and second tubular members after the
10 plastic deformations and radial expansions are substantially equal.

1 88. An apparatus for coupling a first tubular member to a second tubular member,
2 comprising:
3 means for providing a lipped in the first tubular member;
4 means for plastically deforming and radially expanding another portion of the first
5 tubular member;
6 means for positioning the second tubular member inside the first tubular member in
7 overlapping relation to the lipped portion of the first tubular member, and
8 means for plastically deforming and radially expanding the second tubular
9 member;
10 wherein the inside diameters of the first and second tubular members after the
11 plastic deformations and radial expansions are substantially equal.

1 89. An apparatus for forming a wellbore casing within a wellbore, comprising:
2 means for supporting a tubular member within the wellbore;
3 means for providing a lipped portion in the tubular member, and
4 means for plastically deforming and radially expanding another portion of the
5 tubular member to a second outside diameter.

6 90. An apparatus for forming a wellbore casing within a wellbore, comprising:
7 a tubular support member including a first fluid passage;
8 an expansion cone coupled to the tubular support member having a second fluid
9 passage fluidically coupled to the first fluid passage and an outer conical
10 surface;
11 an annular expansion cone launcher comprising:

12 a first annular portion coupled to a lower portion of the tubular member;
13 a second annular portion coupled to the first annular portion that mates with
14 the outer conical surface of the expansion cone;
15 a third annular portion coupled to the second annular portion having a first
16 outside diameter; and
17 a fourth annular portion coupled to the third annular portion having a
18 second outside diameter;
19 wherein the second outside diameter is less than the first outside diameter;
20 and
21 a shoe having a valveable passage coupled to fourth annular portion of the
22 expansion cone launcher.

1 91. A method of forming a wellbore casing in a wellbore, comprising:
2 supporting a tubular member within the wellbore;
3 providing a lipped portion in a portion of the tubular member; and
4 plastically deforming and radially expanding another portion of the tubular
5 member.

1 92. The method of claim 91, further comprising:
2 injecting a hardenable fluidic sealing material in an annulus between the tubular
3 member and the wellbore.

1 93. The method of claim 92, further comprising:
2 curing the fluidic sealing material.

1 94. A method of forming a mono-diameter wellbore casing within a wellbore,
2 comprising:
3 supporting a first tubular member within the wellbore;
4 providing a lipped portion in a portion of the first tubular member;
5 plastically deforming and radially expanding another portion of the first tubular
6 member;
7 positioning the second tubular member inside the first tubular member in
8 overlapping relation to the lipped portion of the first tubular member; and

9 plastically deforming and radially expanding the second tubular member,
10 wherein the inside diameters of the first and second tubular members after the
11 plastic deformations and radial expansions are substantially equal.

1 95. The method of claim 94, further comprising:
2 injecting a hardenable fluidic sealing material in an annulus between the first
3 tubular member and the wellbore.

1 96. The method of claim 95, further comprising:
2 curing the fluidic sealing material.

3 97. The method of claim 94, further comprising:
4 injecting a hardenable fluidic sealing material in an annulus between the second
5 tubular member and the wellbore.

1 98. The method of claim 97, further comprising:
2 curing the fluidic sealing material.

1 99. An apparatus for forming a mono-diameter wellbore casing within a wellbore,
2 comprising:
3 means for providing a lipped in the first tubular member;
4 means for plastically deforming and radially expanding another portion of the first
5 tubular member;
6 means for positioning the second tubular member inside the first tubular member in
7 overlapping relation to the lipped portion of the first tubular member; and
8 means for plastically deforming and radially expanding the second tubular
9 member;
10 wherein the inside diameters of the first and second tubular members after the
11 plastic deformations and radial expansions are substantially equal.

1 100. The apparatus of claim 99, further comprising:
2 means for injecting a hardenable fluidic sealing material in an annulus between the
3 first tubular member and the wellbore.

1 101. The apparatus of claim 100, further comprising:
2 means for curing the fluidic sealing material.

1 102. The apparatus of claim 99, further comprising:
2 means for injecting a hardenable fluidic sealing material in an annulus between the
3 second tubular member and the wellbore.

1 103. The apparatus of claim 102, further comprising:
2 means for curing the fluidic sealing material.

- 1 104. An apparatus for plastically deforming and radially expanding a tubular member,
2 comprising:
3 means for plastically deforming and radially expanding a first end of the tubular
4 member; and
5 means for plastically deforming and radially expanding a second end of the tubular
6 member.
- 1 105. The apparatus of claim 104, further comprising:
2 means for anchoring the tubular member during the radial expansion.
- 1 106. An apparatus for plastically deforming and radially expanding a tubular member,
2 comprising:
3 a tubular support member including a first passage;
4 an expansion cone coupled to the tubular support having a second passage fluidically
5 coupled to the first passage and an outer conical surface;
6 an annular expansion cone launcher movably coupled to outer conical surface of
7 the expansion cone;
8 an expandable tubular member coupled to an end of the annular expansion cone
9 launcher;
10 a shoe coupled to another end of the annular expansion cone launcher having a
11 valveable fluid passage; and
12 another annular expansion cone movably coupled to the tubular support member;
13 wherein the annular expansion cones are positioned in opposite orientations.
- 1 107. The apparatus of claim 106, wherein the annular expansion cone is adapted to
2 plastically deform and radially expand a first end of the expandable tubular member and
3 the other annular expansion cone is adapted to plastically deform and radially expand a
4 second end of the expandable tubular member.
- 1 108. The apparatus of claim 106, further comprising:
2 an anchoring member coupled to the tubular support member adapted to hold the
3 expandable tubular.

- 1 109. A method of plastically deforming and radially expanding a tubular member,
2 comprising:
3 plastically deforming and radially expanding a first end of the tubular member; and
4 plastically deforming and radially expanding a second end of the tubular member.
- 1 110. The method of claim 109, further comprising:
2 anchoring the tubular member during the radial expansion.
- 1 111. The method of claim 109, wherein the first end of the tubular member is plastically
2 deformed and radially expanded before the second end.
- 1 112. The method of claim 109, plastically deforming and radially expanding the second
2 end of the tubular member comprises injecting a fluidic material into the tubular member.
- 1 113. A method of coupling a first tubular member to a second tubular member,
2 comprising:
3 positioning the second tubular member inside the first tubular member in an
4 overlapping relationship;
5 plastically deforming and radially expanding the end of the second tubular member
6 that overlaps with the first tubular member;
7 plastically deforming and radially expanding the remaining portion of the second
8 tubular member.
- 1 114. The method of claim 113, further comprising:
2 plastically deforming and radially expanding at least a portion of the second tubular
3 member.
- 1 115. The method of claim 114, wherein the inside diameters of the first and second
2 tubular members are substantially equal after the radial expansions.
- 1 116. An apparatus for coupling a first tubular member to a second tubular member,
2 comprising:

3 means for positioning the second tubular member inside the first tubular member in
4 an overlapping relationship;

5 means for plastically deforming and radially expanding the end of the second
6 tubular member that overlaps with the first tubular member;

7 means for plastically deforming and radially expanding the remaining portion of
8 the second tubular member.

1 117. The apparatus of claim 116, further comprising:

2 means for plastically deforming and radially expanding at least a portion of the
3 second tubular member.

1 118. The apparatus of claim 117, wherein the inside diameters of the first and second
2 tubular members are substantially equal after the radial expansions.

1 119. An apparatus for forming a wellbore casing within a wellbore, comprising:

2 means for supporting a tubular member within the wellbore;

3 means for plastically deforming and radially expanding a first end of the tubular
4 member; and

5 means for plastically deforming and radially expanding a second end of the tubular
6 member.

1 120. The apparatus of claim 119, further comprising:

2 means for anchoring the tubular member during the radial expansion.

1 121. The apparatus of claim 119, further comprising:

2 means for injecting a hardenable fluidic sealing material into an annulus between
3 the tubular member and the wellbore.

1 122. An apparatus for forming a wellbore casing within a wellbore, comprising:

2 a tubular support member including a first passage;

3 an expansion cone coupled to the tubular support having a second passage fluidically
4 coupled to the first passage and an outer conical surface;

5 an annular expansion cone launcher movably coupled to outer conical surface of
6 the expansion cone;
7 an expandable tubular member coupled to an end of the annular expansion cone
8 launcher;
9 a shoe coupled to another end of the annular expansion cone launcher having a
10 valveable fluid passage; and
11 another annular expansion cone movably coupled to the tubular support member;
12 wherein the annular expansion cones are positioned in opposite orientations.

✓ 1 123. The apparatus of claim 122, wherein the annular expansion cone is adapted to
2 plastically deform and radially expand a first end of the expandable tubular member and
3 the other annular expansion cone is adapted to plastically deform and radially expand a
4 second end of the expandable tubular member.

1 124. The apparatus of claim 122, further comprising:
2 an anchoring member coupled to the tubular support member adapted to hold the
3 expandable tubular.

1 125. A method of forming a wellbore casing within a wellbore, comprising:
2 plastically deforming and radially expanding a first end of the tubular member; and
3 plastically deforming and radially expanding a second end of the tubular member.

1 126. The method of claim 125, further comprising:
2 anchoring the tubular member during the radial expansion.

1 127. The method of claim 125, wherein the first end of the tubular member is plastically
2 deformed and radially expanded before the second end.

1 128. The method of claim 125, plastically deforming and radially expanding the second
2 end of the tubular member comprises injecting a fluidic material into the tubular member.

1 129. The method of claim 125, further comprising:

2 injecting a hardenable fluidic sealing material into an annulus between the tubular
3 member and the wellbore.

1 130. A method of forming a wellbore casing within a wellbore, comprising:
2 plastically deforming and radially expanding a first tubular member within the
3 wellbore;
4 positioning a second tubular member inside the first tubular member in an
5 overlapping relationship;
6 plastically deforming and radially expanding the end of the second tubular member
7 that overlaps with the first tubular member;
8 plastically deforming and radially expanding the remaining portion of the second
9 tubular member.

1 131. The method of claim 130, further comprising:
2 plastically deforming and radially expanding at least a portion of the second tubular
3 member.

1 132. The method of claim 131, wherein the inside diameters of the first and second
2 tubular members are substantially equal after the radial expansions.

1 133. The method of claim 130, further comprising:
2 injecting a hardenable fluidic sealing material into an annulus between the first
3 tubular member and the wellbore.

1 134. The method of claim 130, further comprising:
2 injecting a hardenable fluidic sealing material into an annulus between the second
3 tubular member and the wellbore.

1 135. An apparatus for forming a wellbore casing within a wellbore, comprising:
2 means for plastically deforming and radially expanding a first tubular member
3 within the wellbore;

4 means for positioning the second tubular member inside the first tubular member in
5 an overlapping relationship;
6 means for plastically deforming and radially expanding the end of the second
7 tubular member that overlaps with the first tubular member;
8 means for plastically deforming and radially expanding the remaining portion of
9 the second tubular member.

1 136. The apparatus of claim 135, further comprising:

2 means for plastically deforming and radially expanding at least a portion of the
3 second tubular member.

1 137. The apparatus of claim 136, wherein the inside diameters of the first and second
2 tubular members are substantially equal after the radial expansions.

1 138. The apparatus of claim 135, further comprising:

2 means for injecting a hardenable fluidic sealing material into an annulus between
3 the first tubular member and the wellbore.

1 139. The apparatus of claim 135, further comprising:

2 means for injecting a hardenable fluidic sealing material into an annulus between
3 the second tubular member and the wellbore.

1 140. An apparatus for bridging an axial gap between opposing pairs of wellbore casing
2 within a wellbore, comprising:
3 means for supporting a tubular member in overlapping relation to the opposing
4 ends of the wellbore casings;
5 means for plastically deforming and radially expanding the tubular member; and
6 means for plastically deforming and radially expanding the tubular member and the
7 opposing ends of the wellbore casings.

1 141. A method of bridging an axial gap between opposing pairs of wellbore casing
2 within a wellbore, comprising:
3 supporting a tubular member in overlapping relation to the opposing ends of the
4 wellbore casings;
5 plastically deforming and radially expanding the tubular member; and
6 plastically deforming and radially expanding the tubular member and the opposing
7 ends of the wellbore casings.

1 142. A method of forming a structure having desired strength characteristics,
2 comprising:
3 providing a first tubular member; and
4 plastically deforming and radially expanding additional tubular members onto the
5 interior surface of the first tubular member until the desired strength
6 characteristics are achieved.

1 143. A method of forming a wellbore casing within a wellbore having desired strength
2 characteristics, comprising:
3 plastically deforming and radially expanding a first tubular member within the
4 wellbore; and
5 plastically deforming and radially expanding additional tubular members onto the
6 interior surface of the first tubular member until the desired strength
7 characteristics are achieved.

1 144. A method of coupling a first tubular member to a second tubular member, the first
2 tubular member having an original outside diameter OD_0 and an original wall thickness t_0 ,
3 comprising:
4 plastically deforming and radially expanding a first portion of the first tubular
5 member to a first outside diameter;
6 plastically deforming and radially expanding another portion of the first tubular
7 member to a second outside diameter;
8 positioning the second tubular member inside the first tubular member in
9 overlapping relation to the first portion of the first tubular member;
10 plastically deforming and radially expanding the second tubular member to a third
11 outside diameter; and
12 plastically deforming and radially expanding the second tubular member to a fourth
13 outside diameter;
14 wherein the inside diameters of the first and second tubular members after the
15 plastic deformations and radial expansions are substantially equal; and
16 wherein the ratio of the original outside diameter OD_0 of the first tubular member
17 to the original wall thickness t_0 of the first tubular member is greater than or
18 equal to 16.

1 145. A method of forming a mono-diameter wellbore casing, comprising:
2 positioning a first tubular member within a wellbore, the first tubular member
3 having an original outside diameter OD_0 and an original wall thickness t_0 ;
4 plastically deforming and radially expanding a first portion of the first tubular
5 member to a first outside diameter;
6 plastically deforming and radially expanding another portion of the first tubular
7 member to a second outside diameter;
8 positioning the second tubular member inside the first tubular member in
9 overlapping relation to the first portion of the first tubular member;
10 plastically deforming and radially expanding the second tubular member to a third
11 outside diameter; and
12 plastically deforming and radially expanding the second tubular member to a fourth
13 outside diameter;

14 wherein the inside diameters of the first and second tubular members after the
15 plastic deformations and radial expansions are substantially equal; and
16 wherein the ratio of the original outside diameter OD_0 of the first tubular member
17 to the original wall thickness t_0 of the first tubular member is greater than or
18 equal to 16.

1 146. An apparatus, comprising:
2 a plastically deformed and radially expanded tubular member having a first portion
3 having a first outside diameter and a remaining portion having a second
4 outside diameter;
5 wherein the ratio of the original outside diameter OD_0 of the first tubular member
6 to the original wall thickness t_0 of the first tubular member is greater than or
7 equal to 16.

1 147. An apparatus, comprising:
2 a plastically deformed and radially expanded first tubular member having a first
3 portion having a first outside diameter and a remaining portion having a
4 second outside diameter; and
5 a plastically deformed and radially expanded second tubular member coupled to
6 the first portion of the first tubular member;
7 wherein the ratio of the original outside diameter OD_0 of the first tubular member
8 to the original wall thickness t_0 of the first tubular member is greater than or
9 equal to 16.

1 148. The apparatus of claim 147, wherein the inside diameters of the first and second
2 tubular members are substantially equal.

1 149. A wellbore casing formed in a wellbore, comprising:
2 a plastically deformed and radially expanded first tubular member having a first
3 portion having a first outside diameter and a remaining portion having a
4 second outside diameter; and
5 a plastically deformed and radially expanded second tubular member coupled to
6 the first portion of the first tubular member;

7 wherein the ratio of the original outside diameter OD_0 of the first tubular member
8 to the original wall thickness t_0 of the first tubular member is greater than or
9 equal to 16.

1 150. The casing of claim 149, wherein the inside diameters of the first and second
2 tubular members are substantially equal.

1 151. An apparatus, comprising:
2 a plastically deformed and radially expanded tubular member;
3 wherein the ratio of the original outside diameter OD_0 of the tubular member to the
4 original wall thickness t_0 of the tubular member is greater than or equal to
5 16.

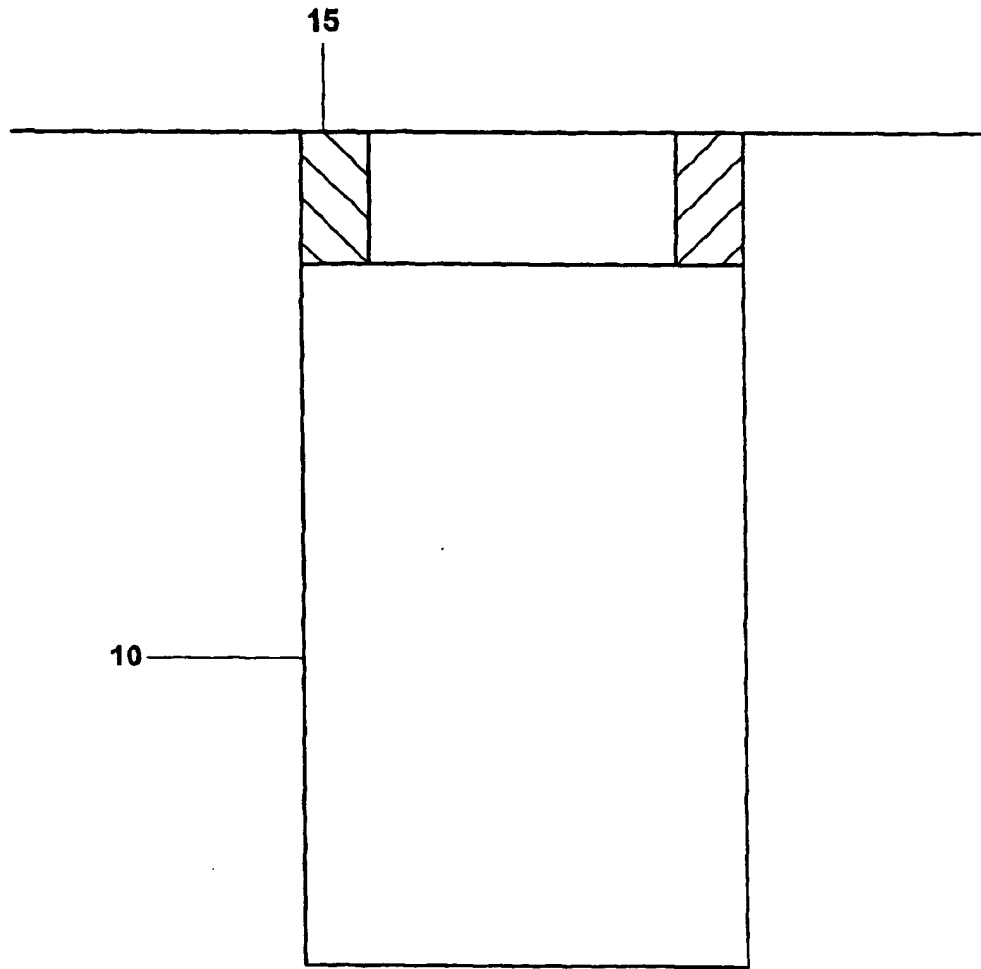

Fig. 1a

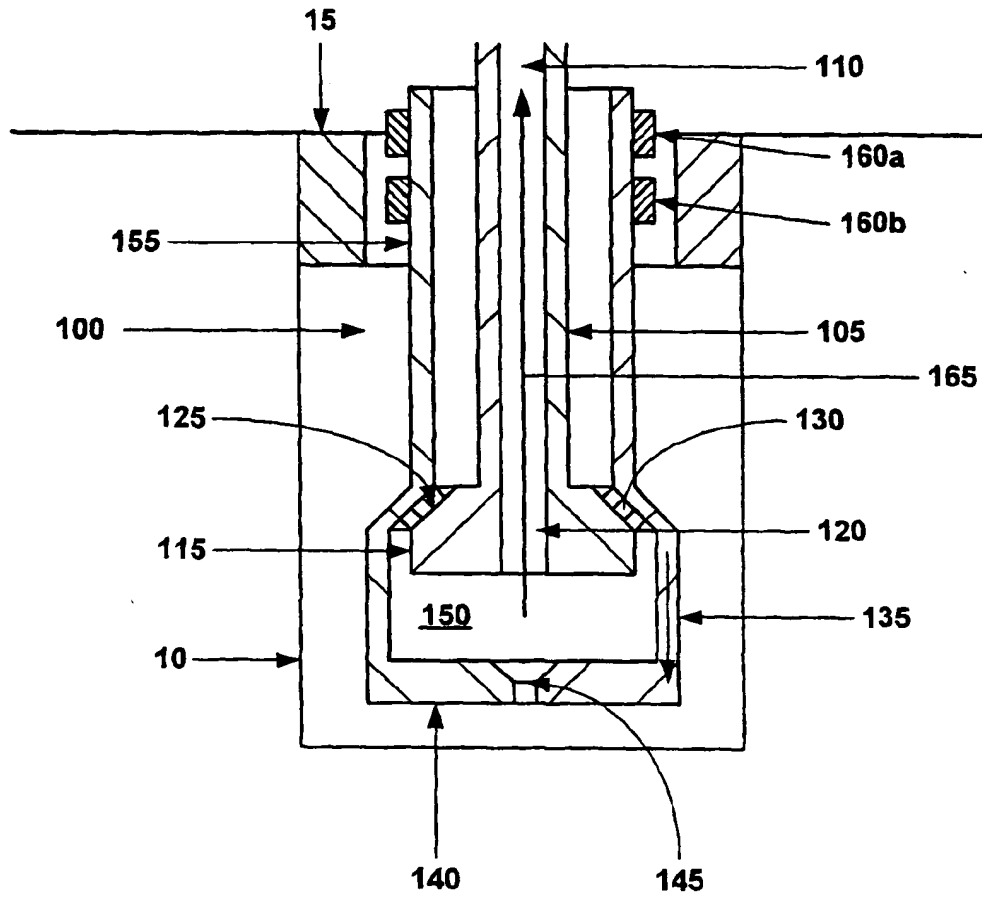

Fig. 1b

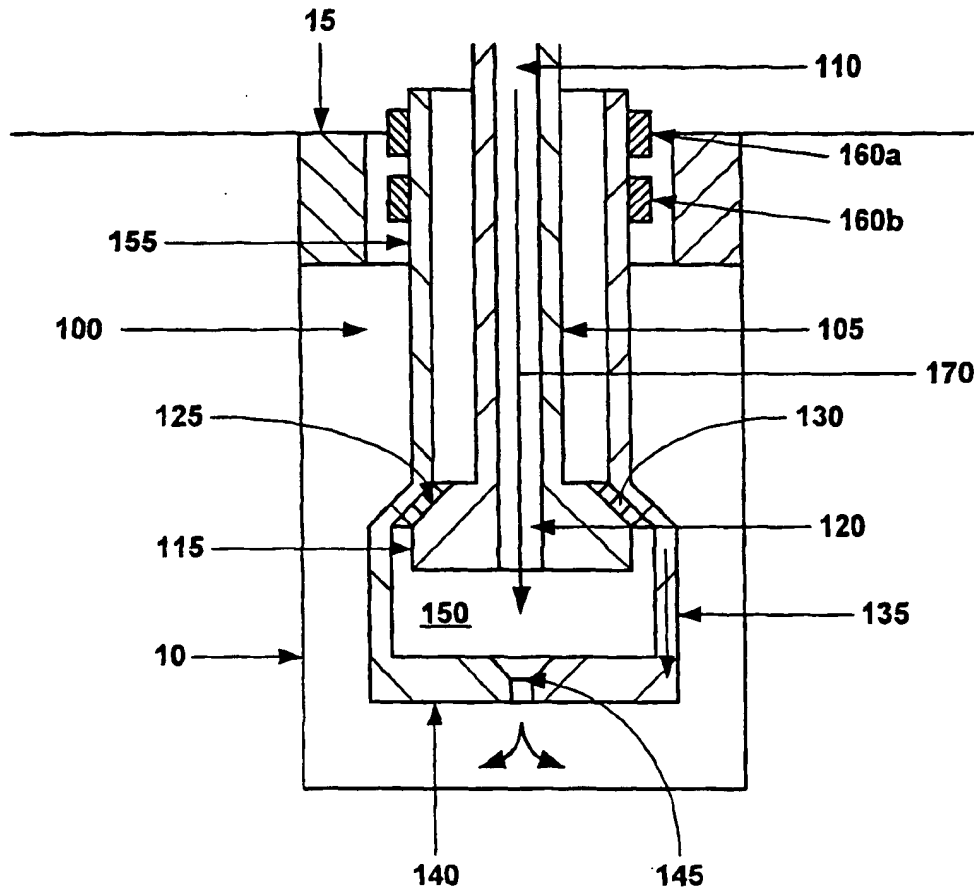

Fig. 1c

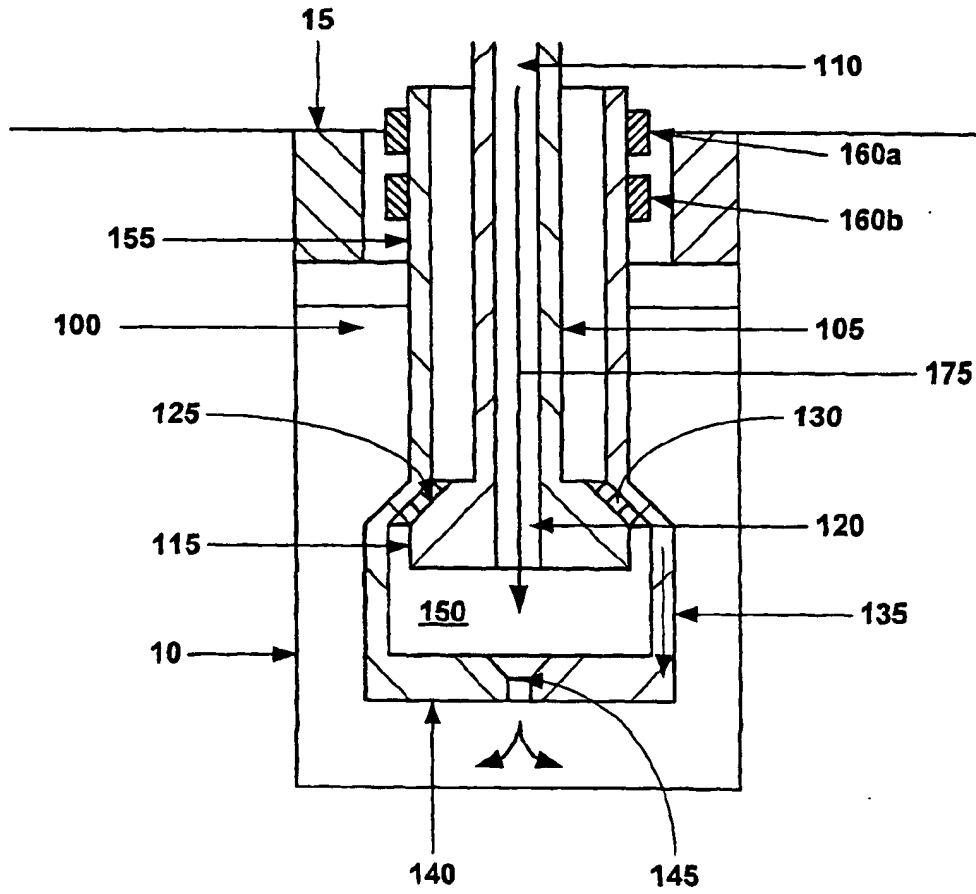

Fig. 1d

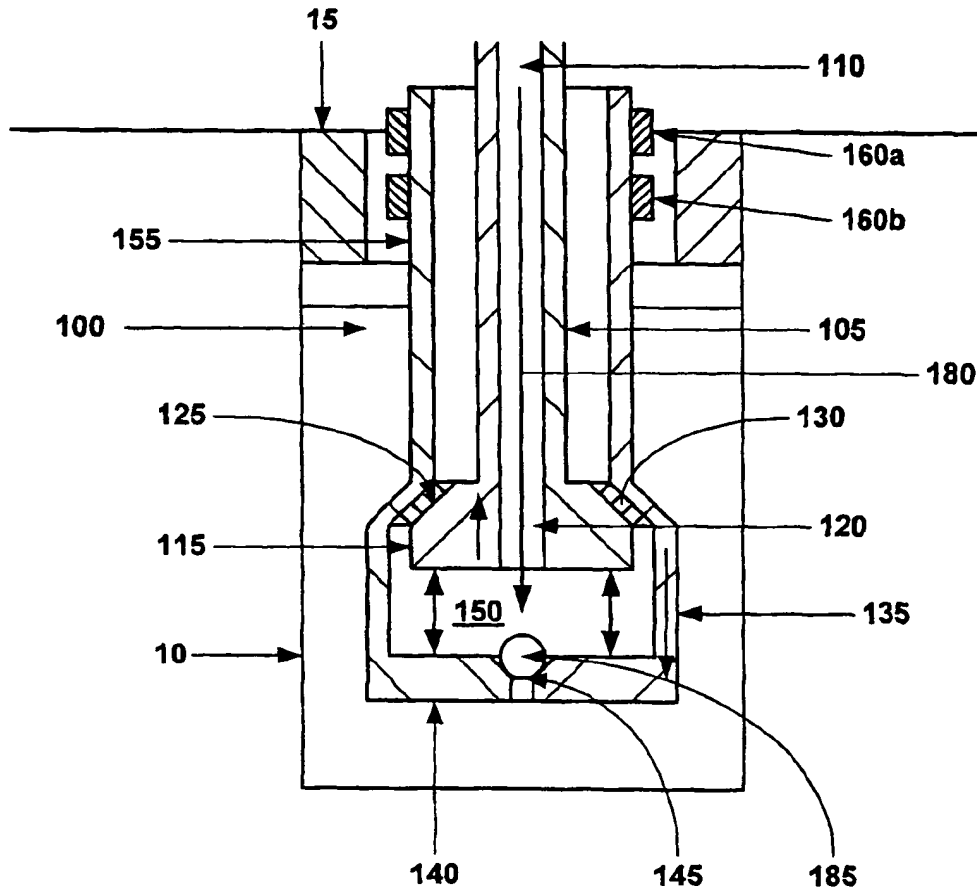

Fig. 1e

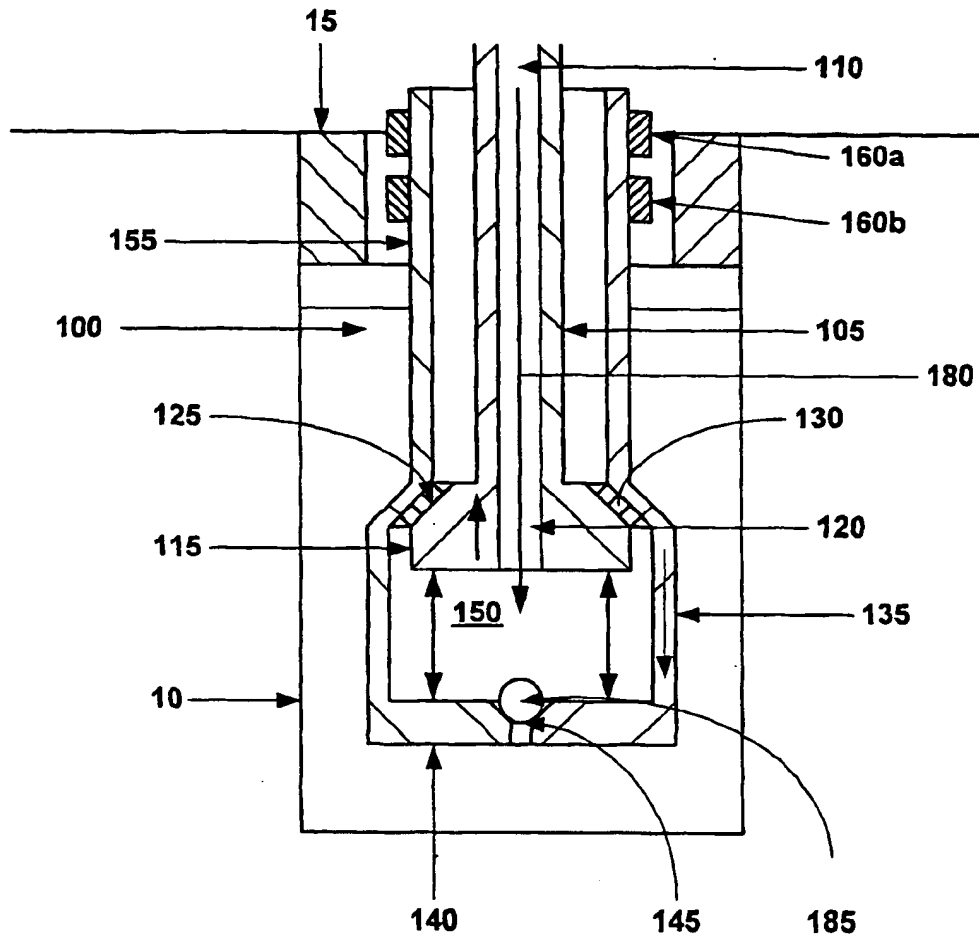

Fig. 1f

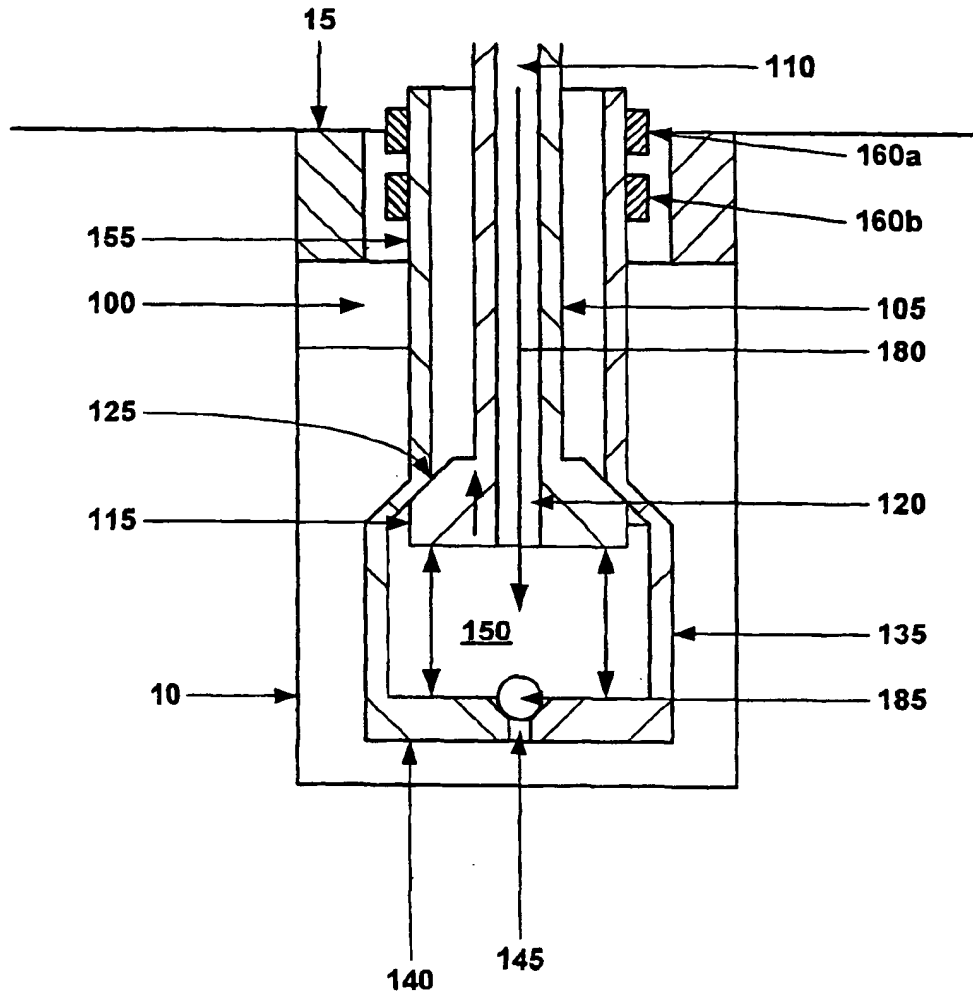

Fig. 1g

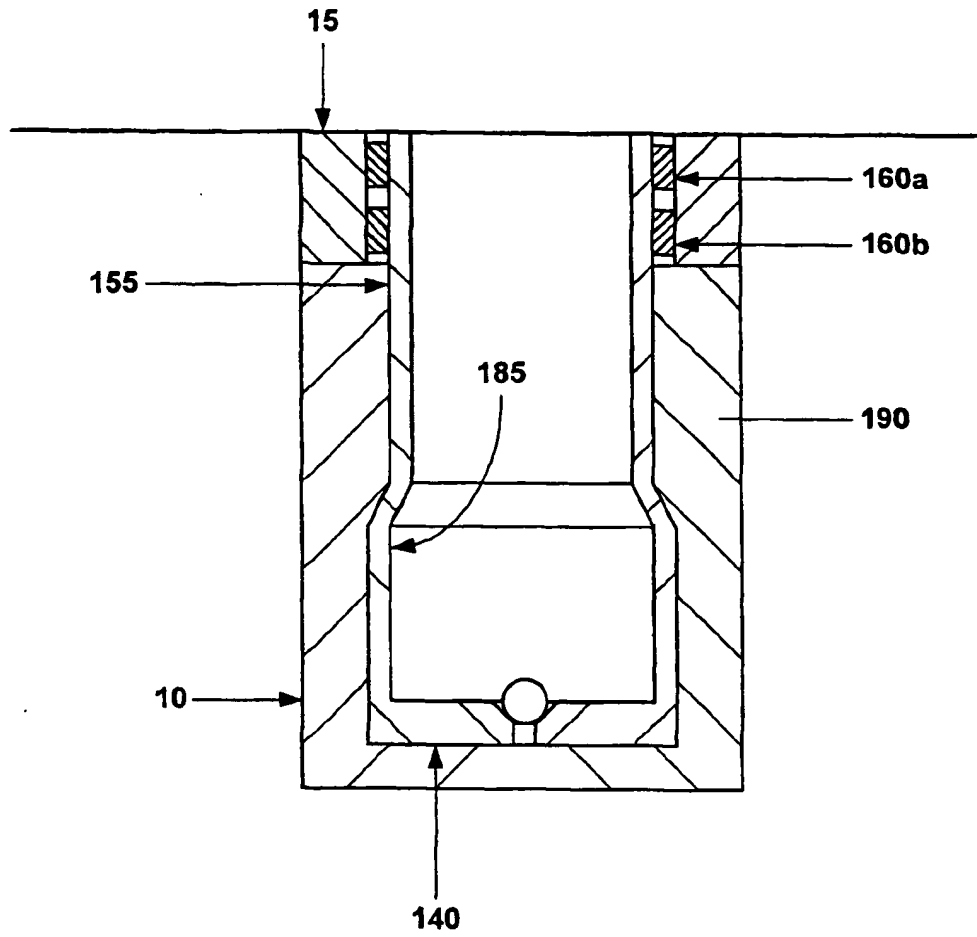

Fig. 1h

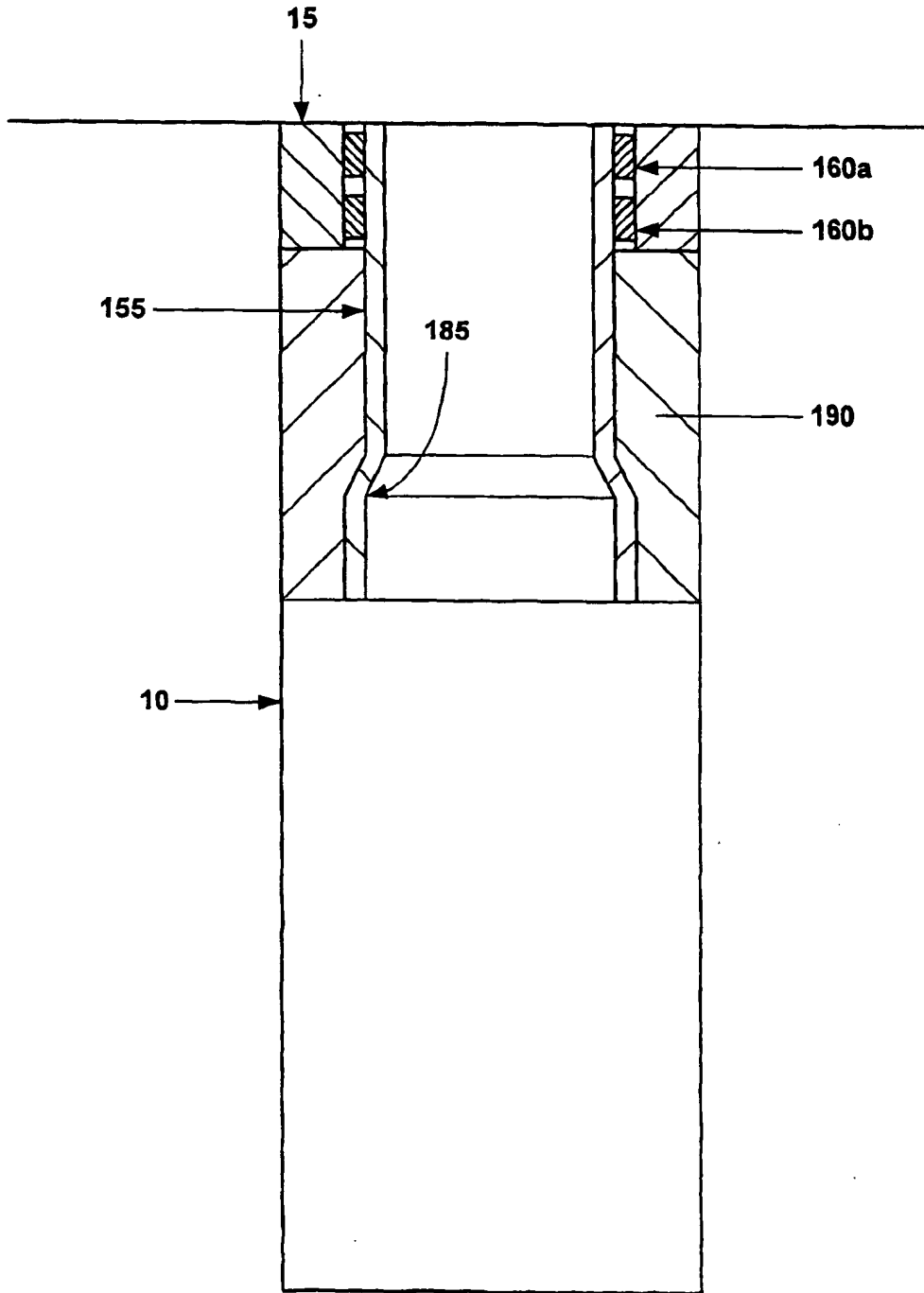

Fig. 1i

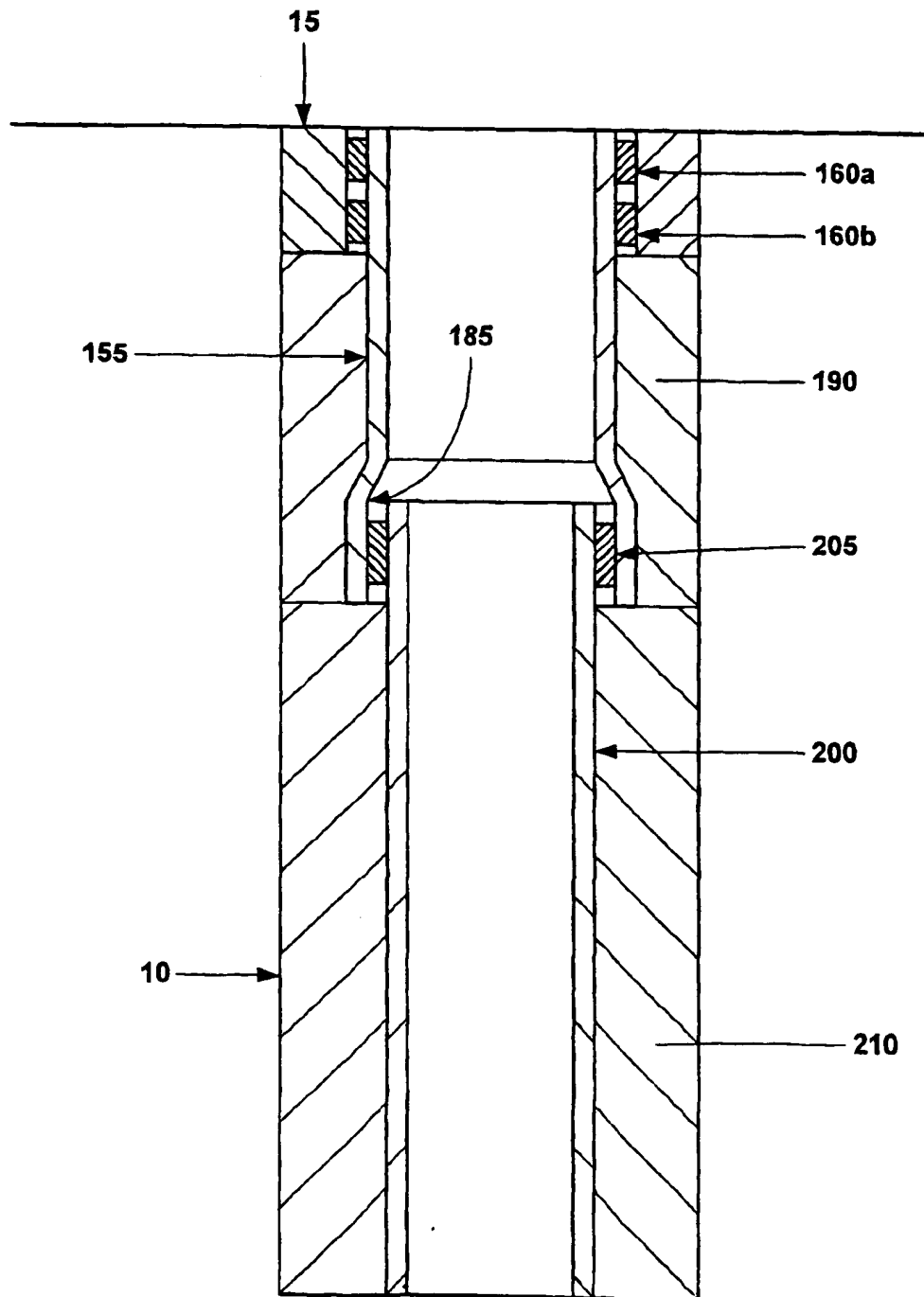

Fig. 1j

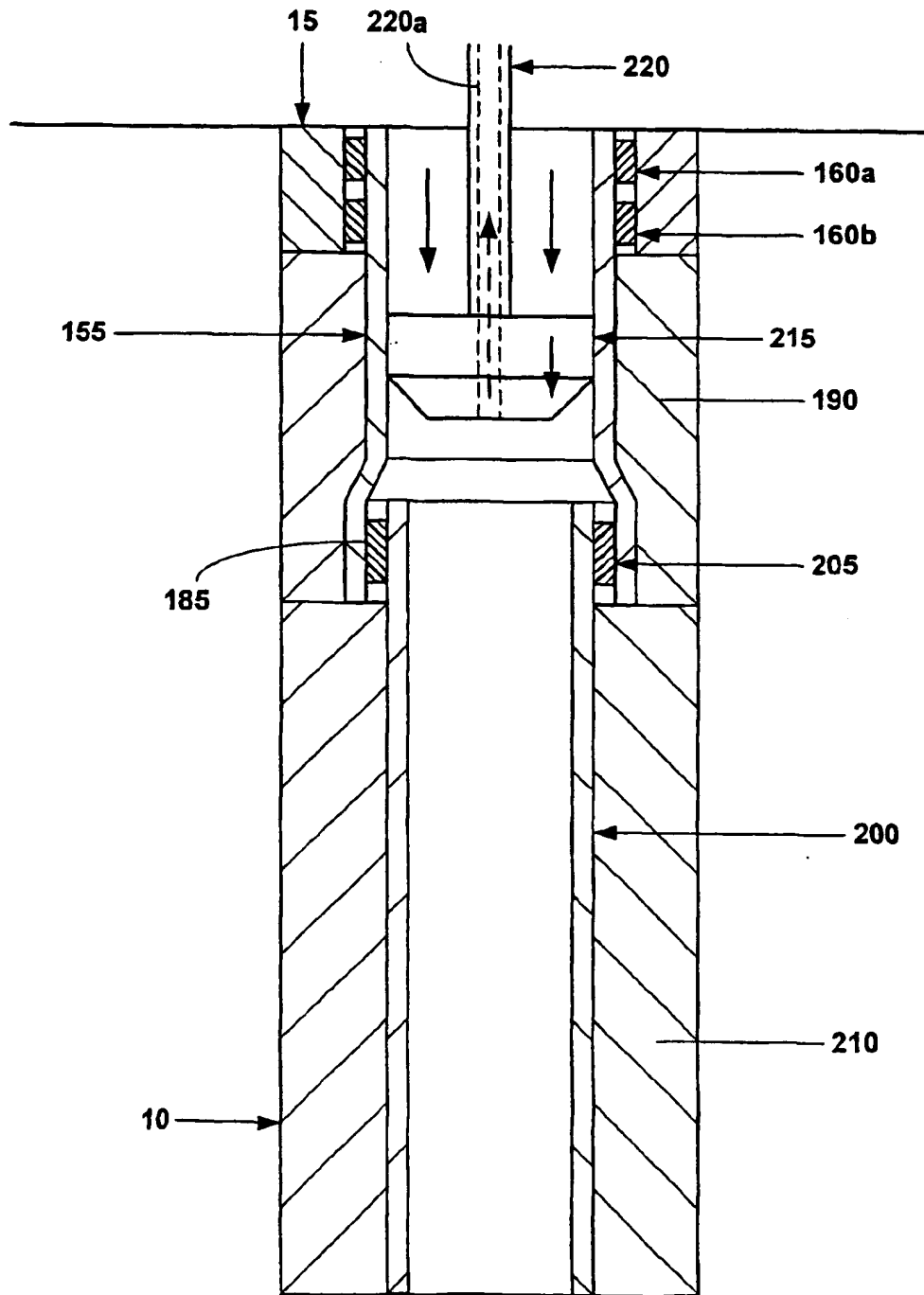

Fig. 1k

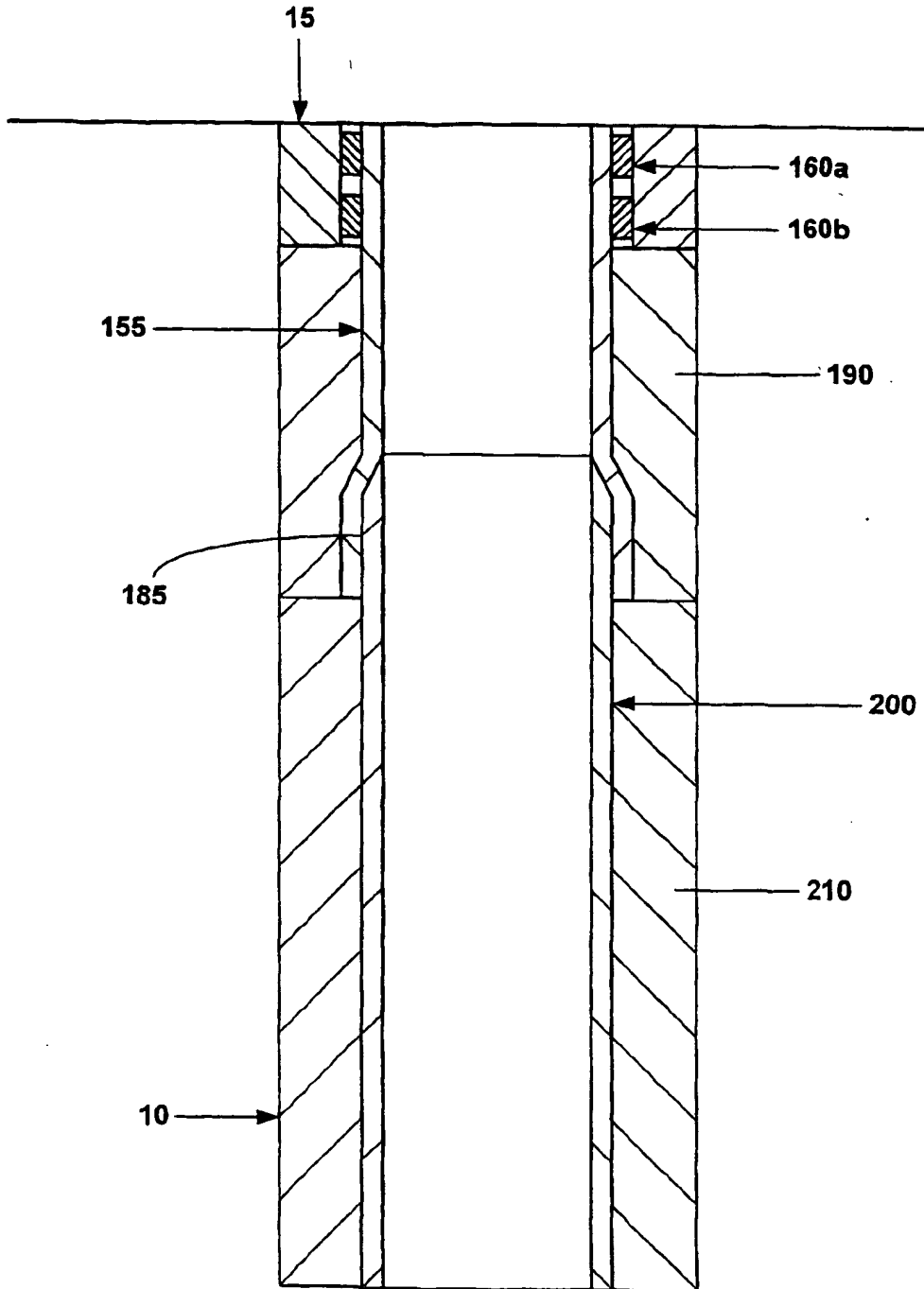

Fig. 11

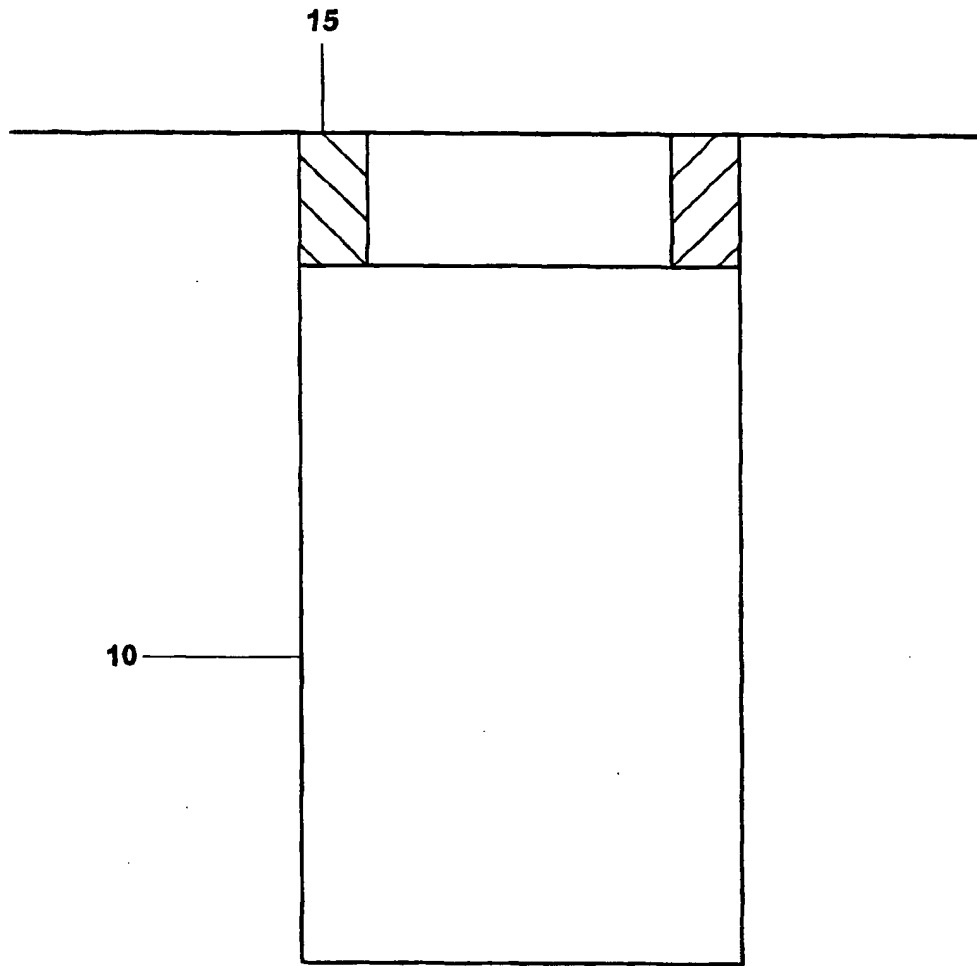

Fig. 2a

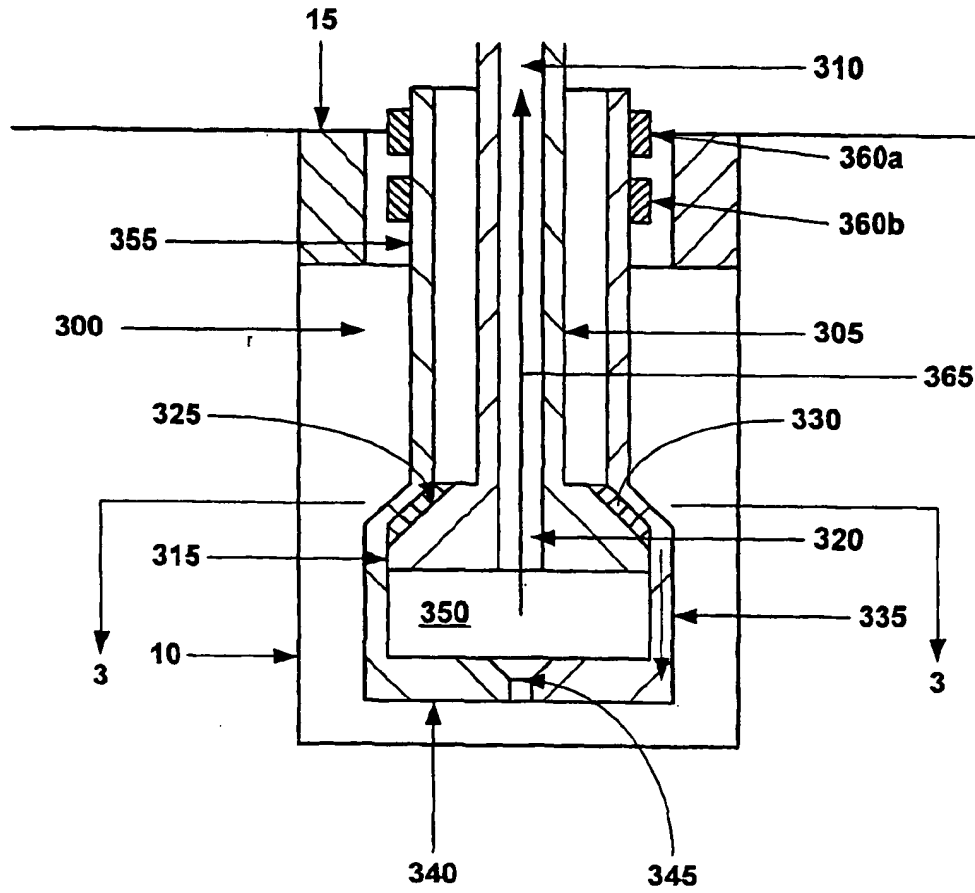

Fig. 2b

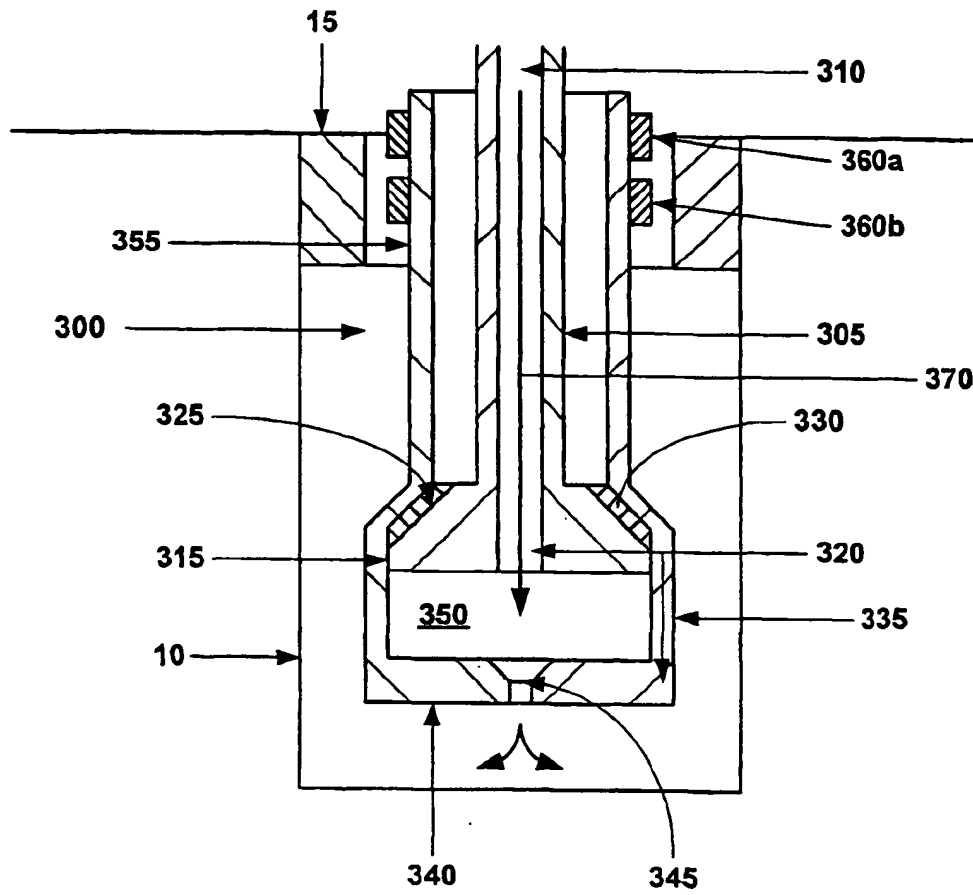

Fig. 2c

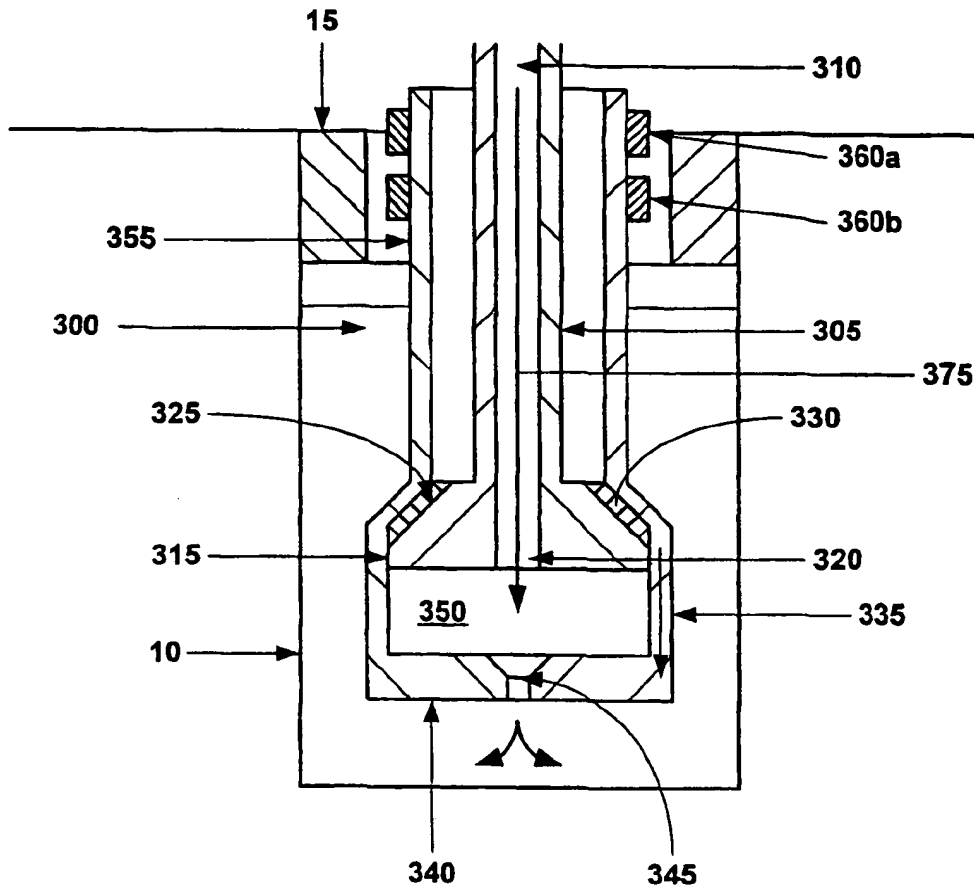

Fig. 2d

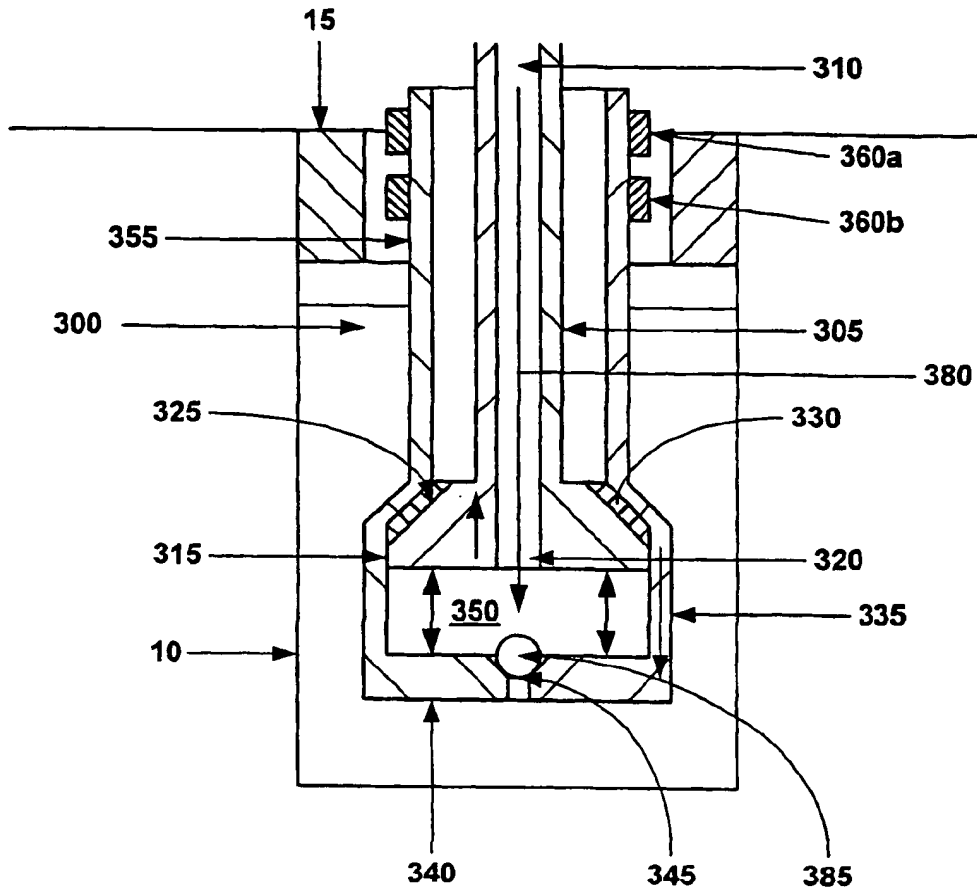

Fig. 2

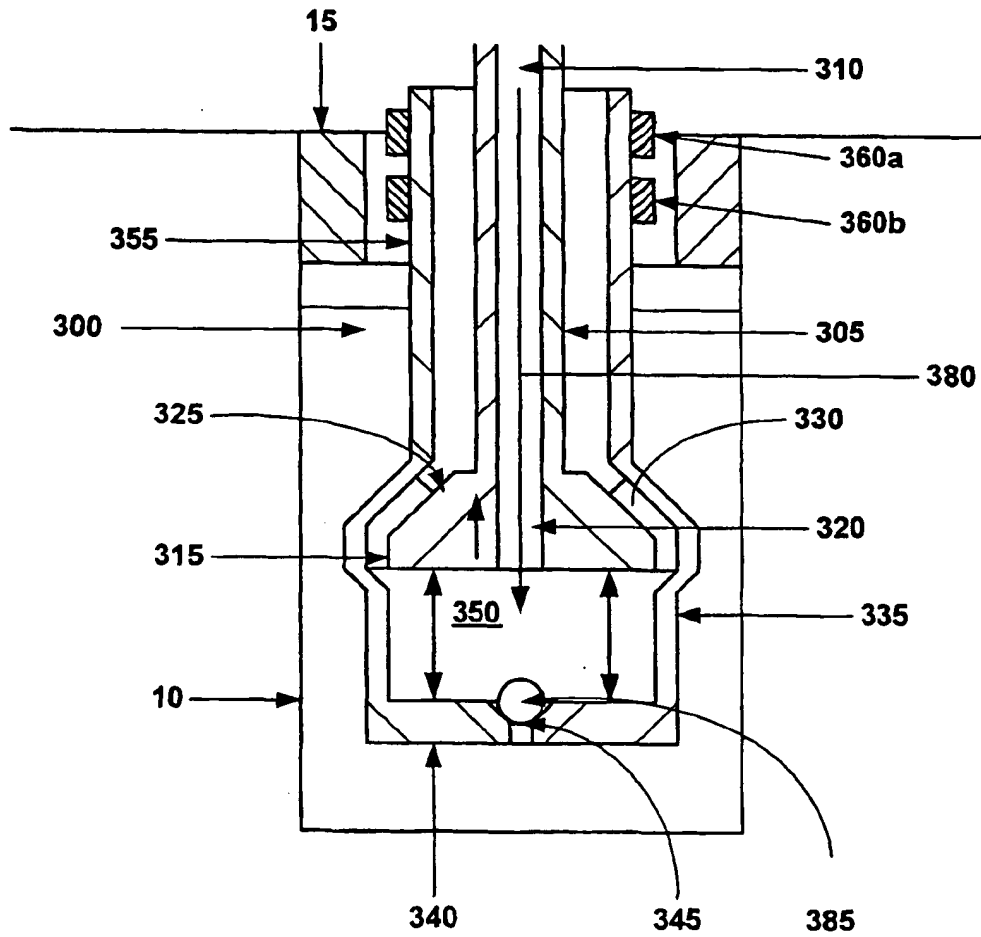

Fig. 2f

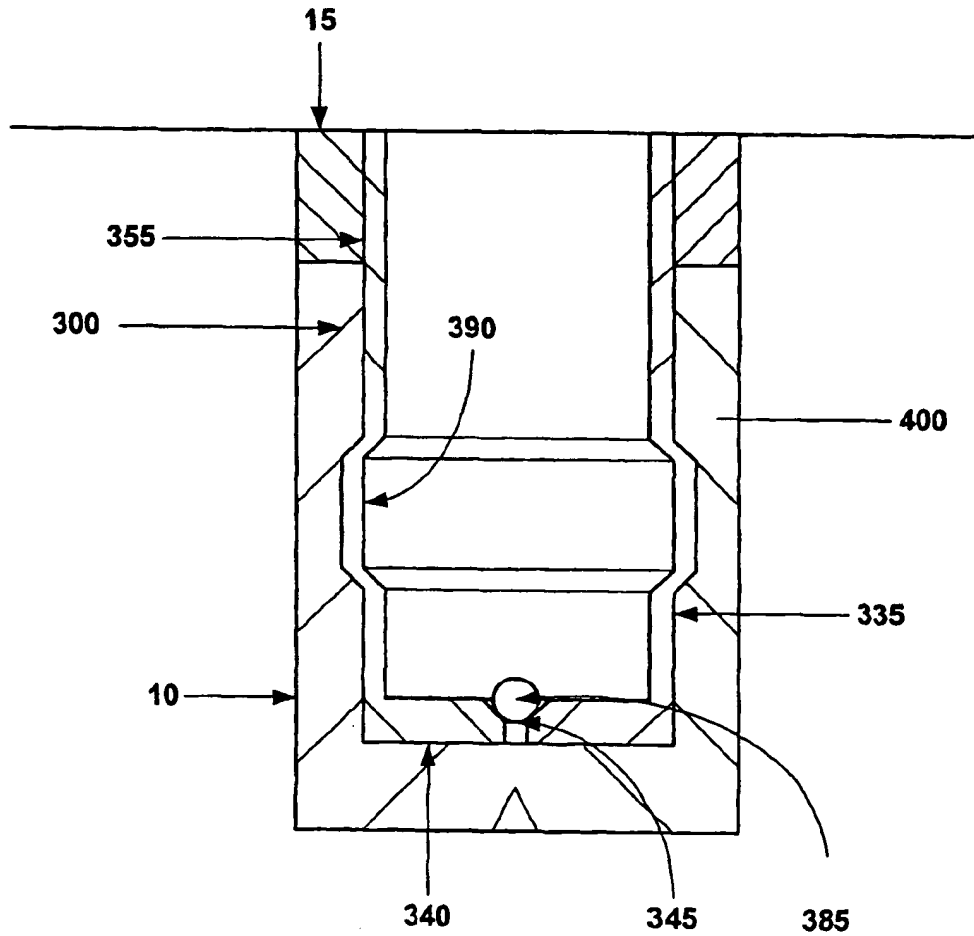

Fig. 2g

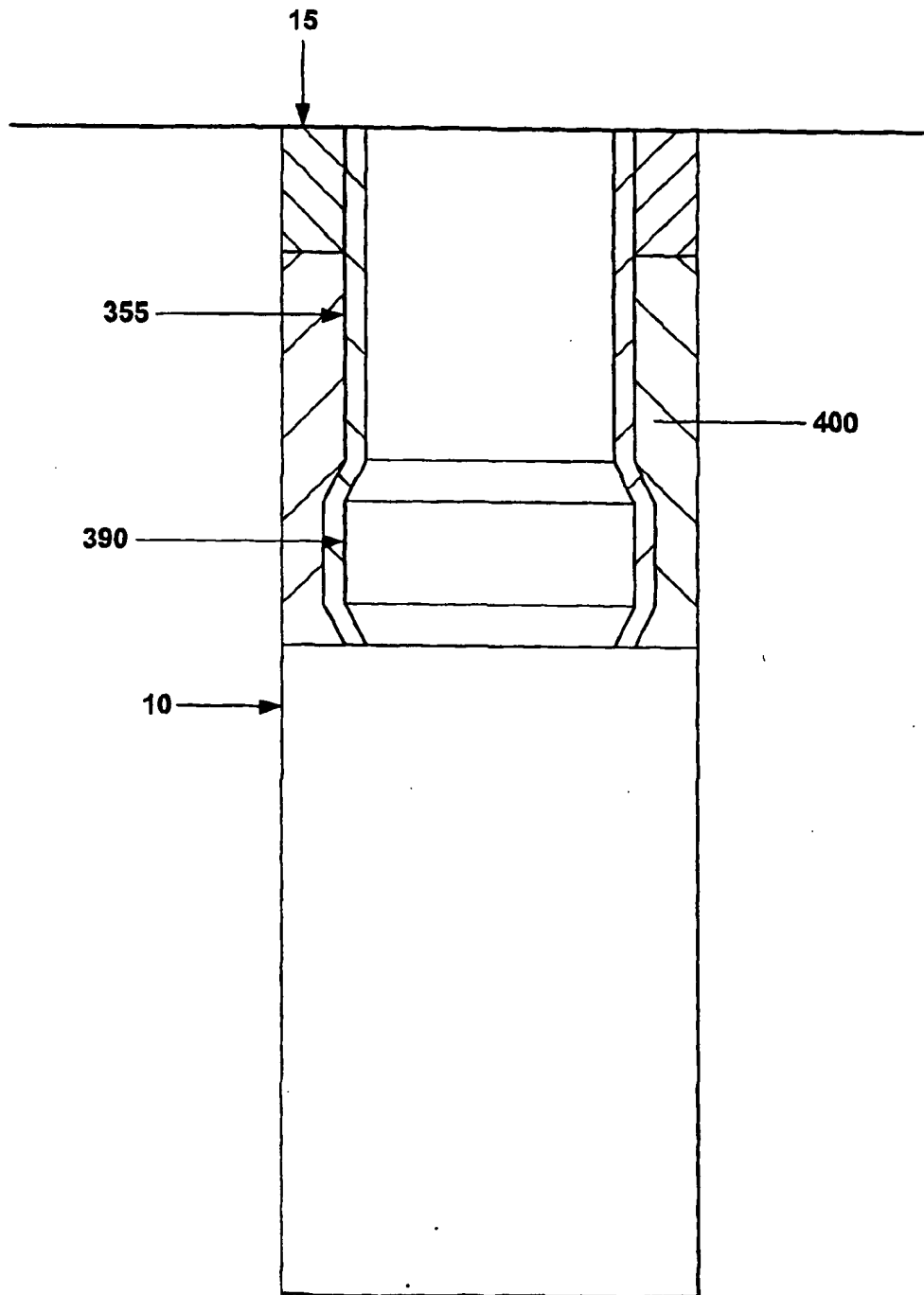

Fig. 2h

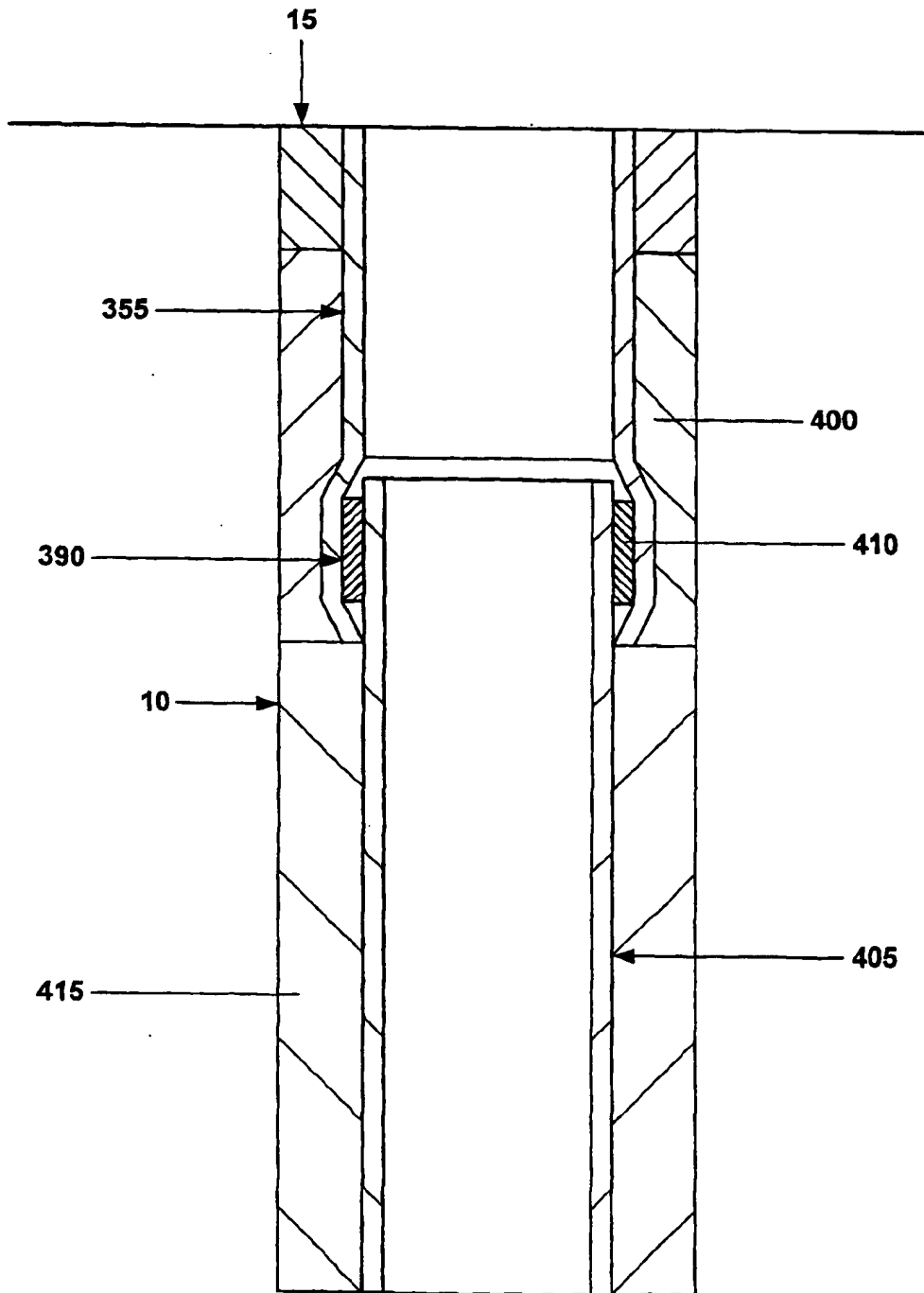

Fig. 2i

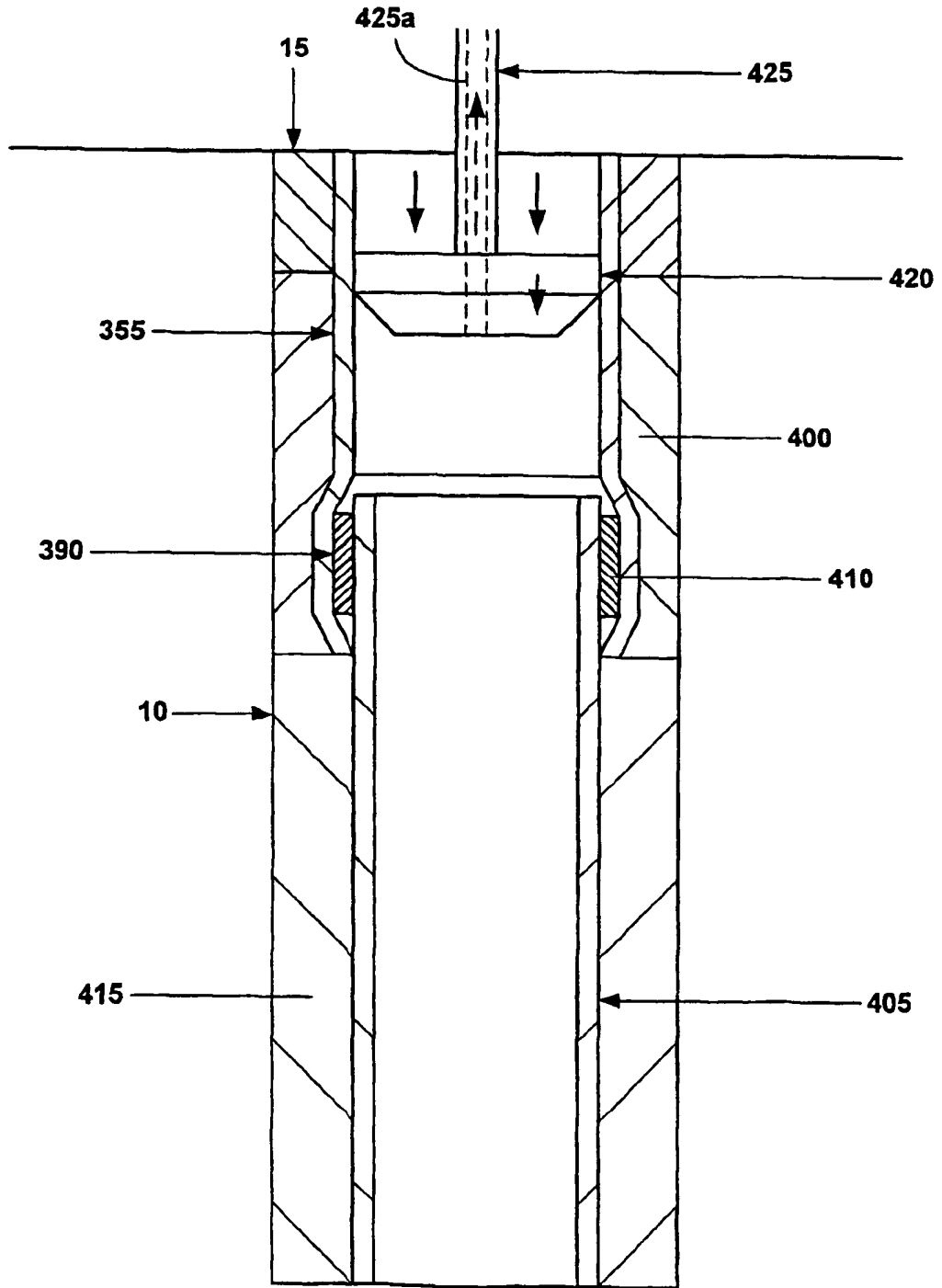

Fig. 2j

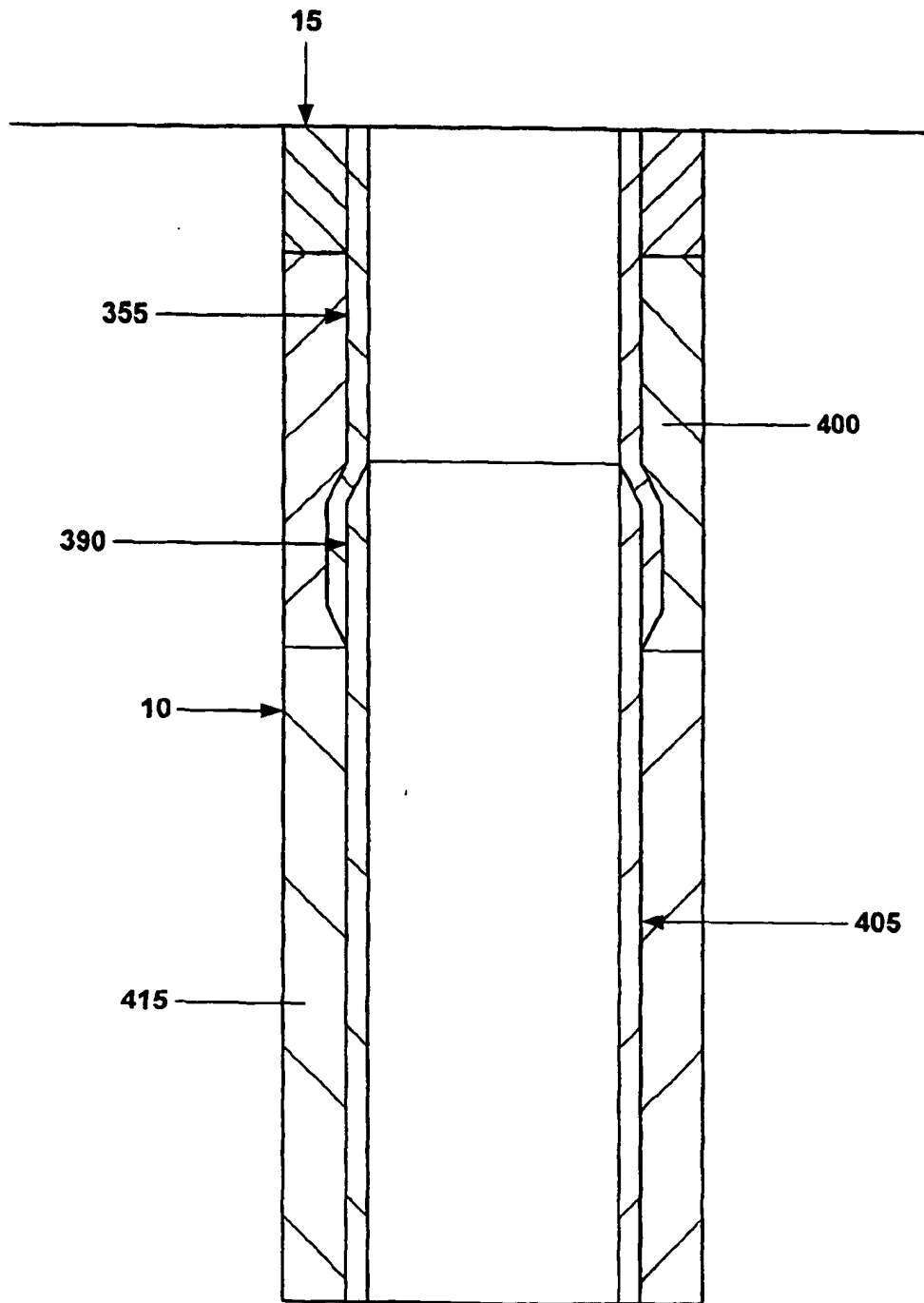

Fig. 2k

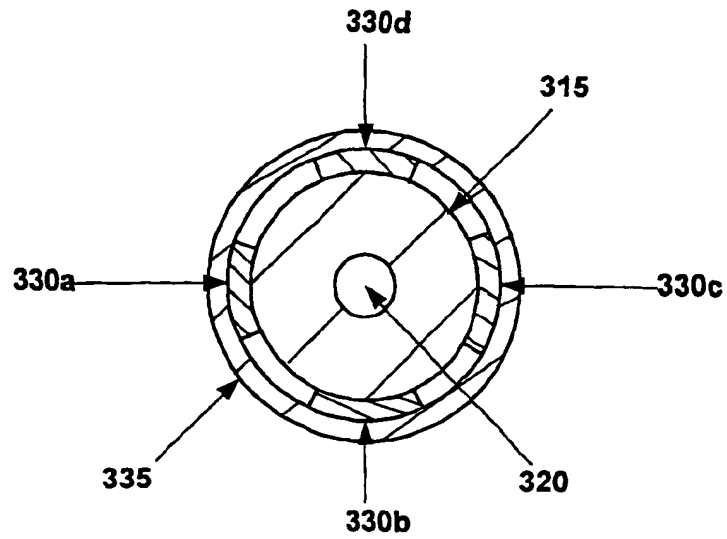

Fig. 3

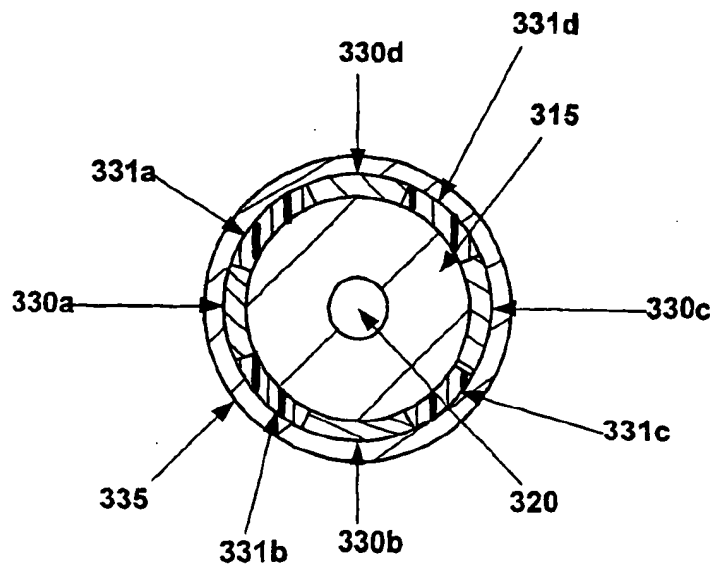

Fig. 3a

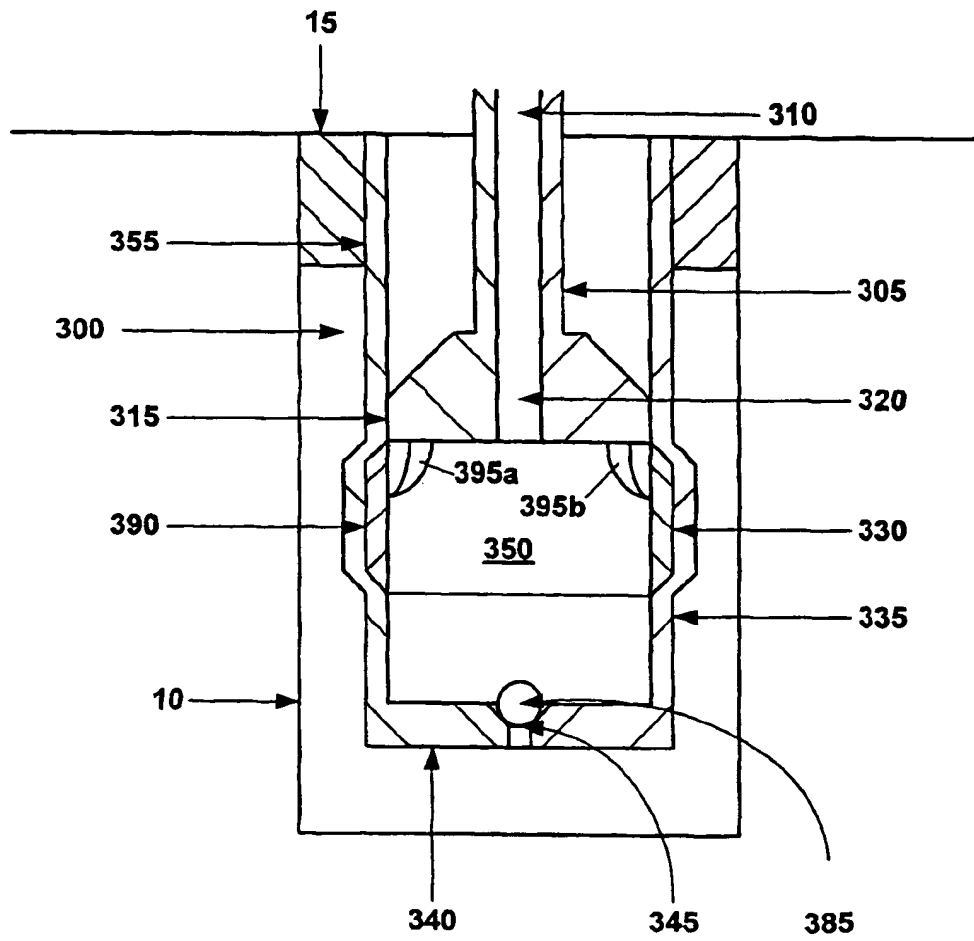

Fig. 4

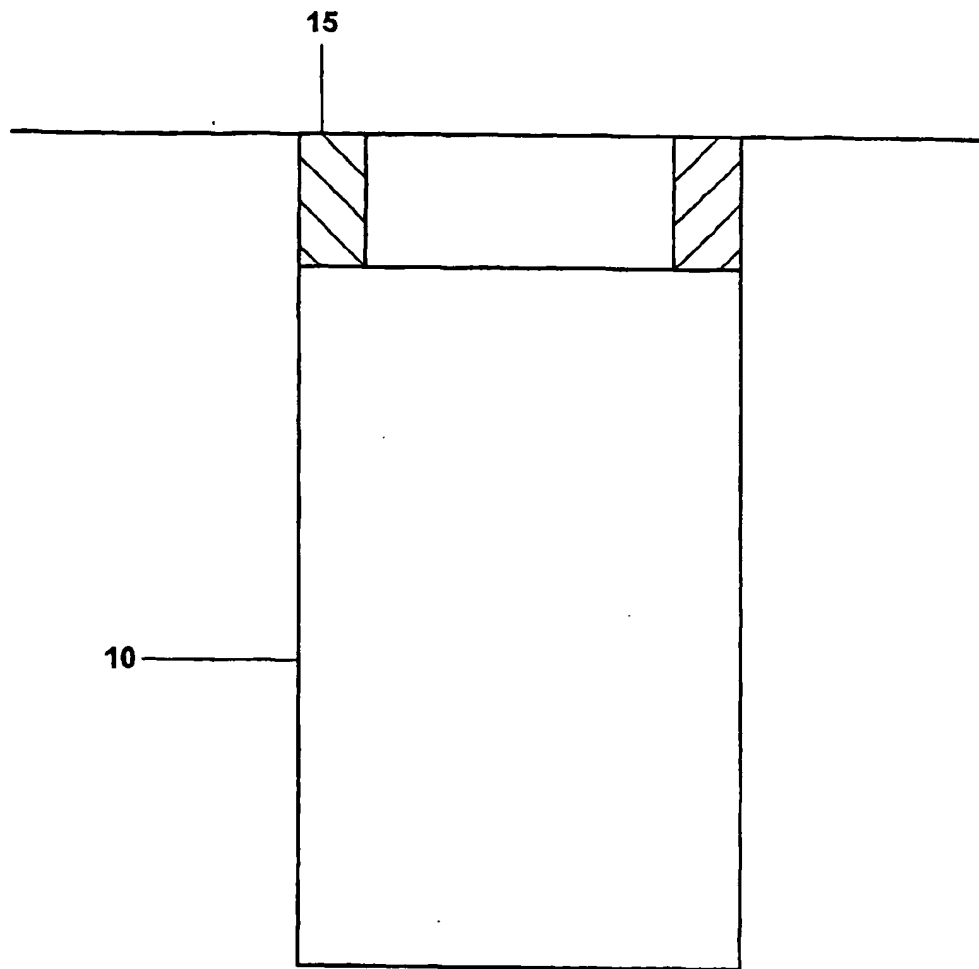

Fig. 5a

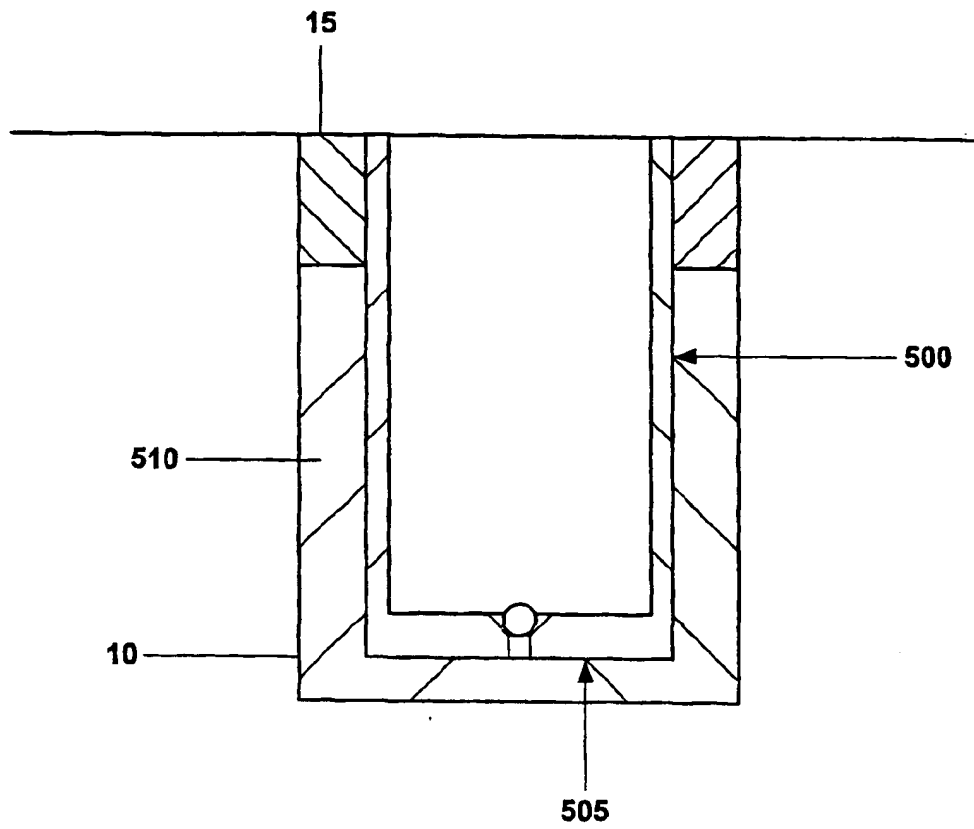

Fig. 5b

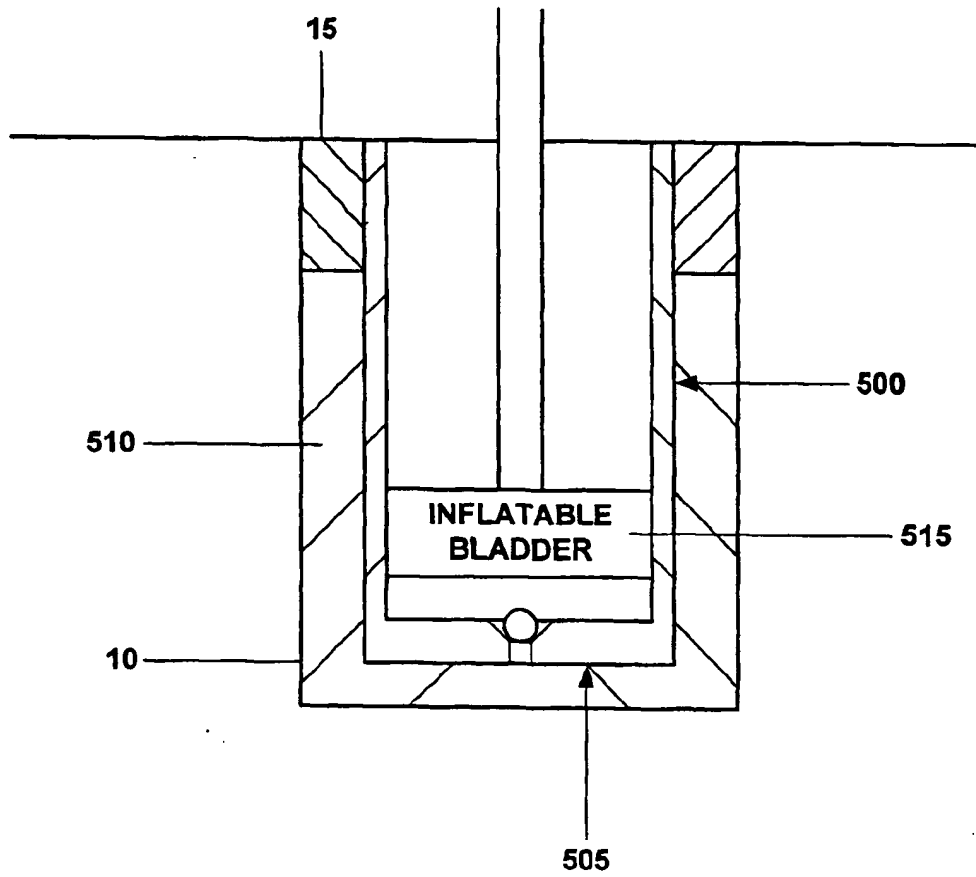

Fig. 5c

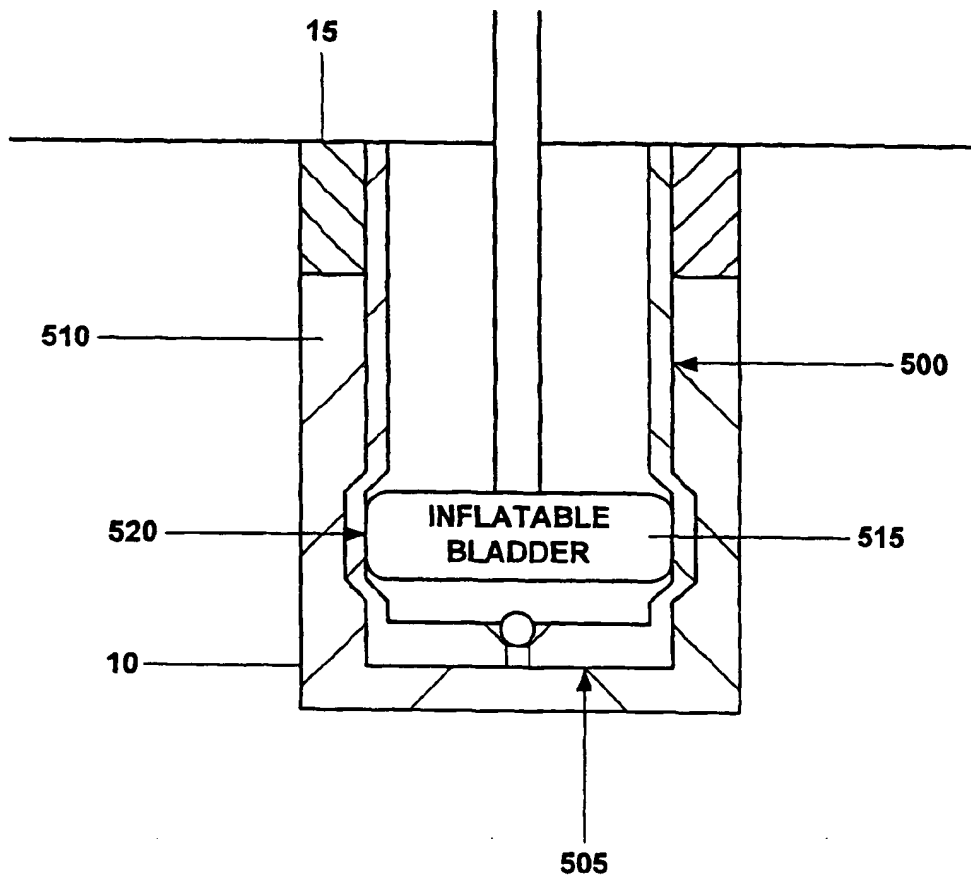

Fig. 5d

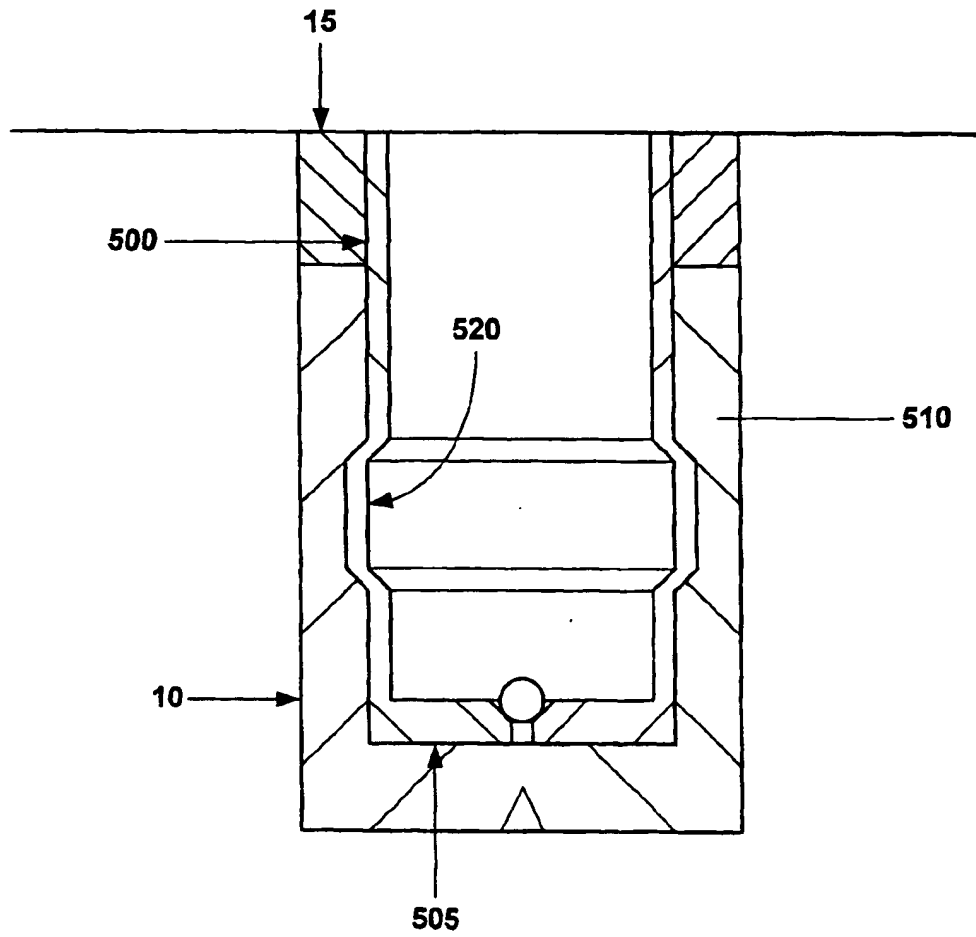

Fig. 5e

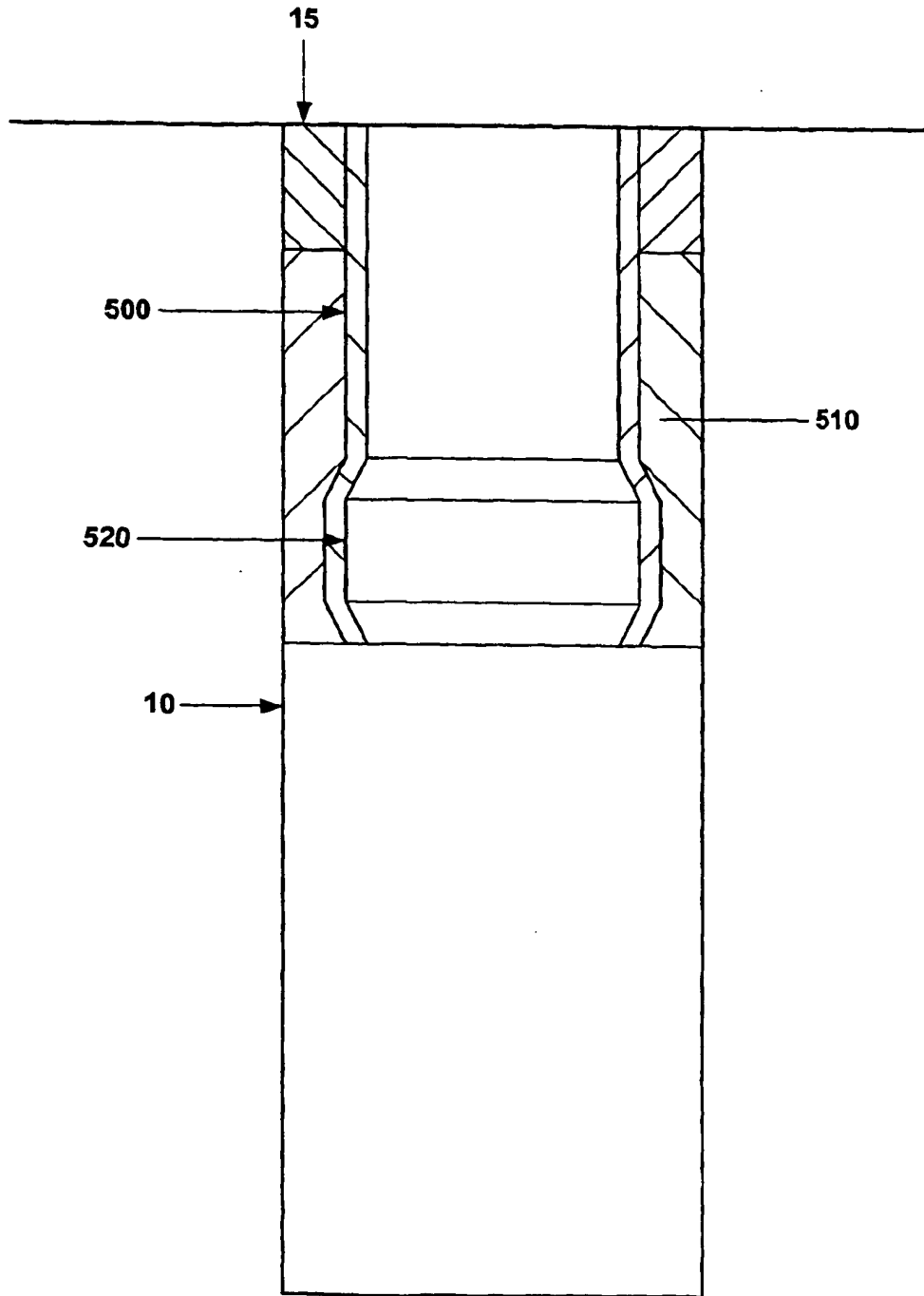

Fig. 5f

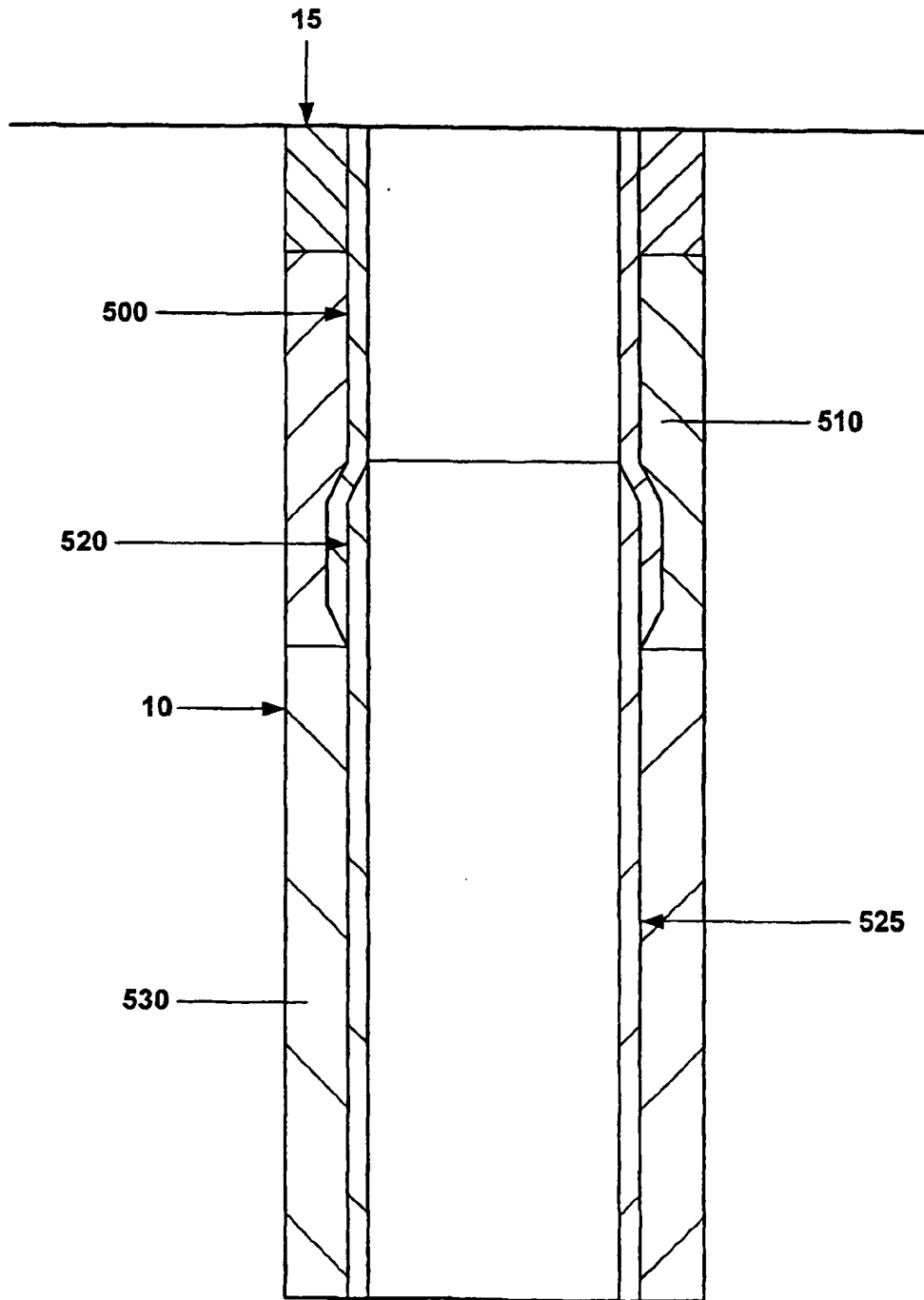

Fig. 5g

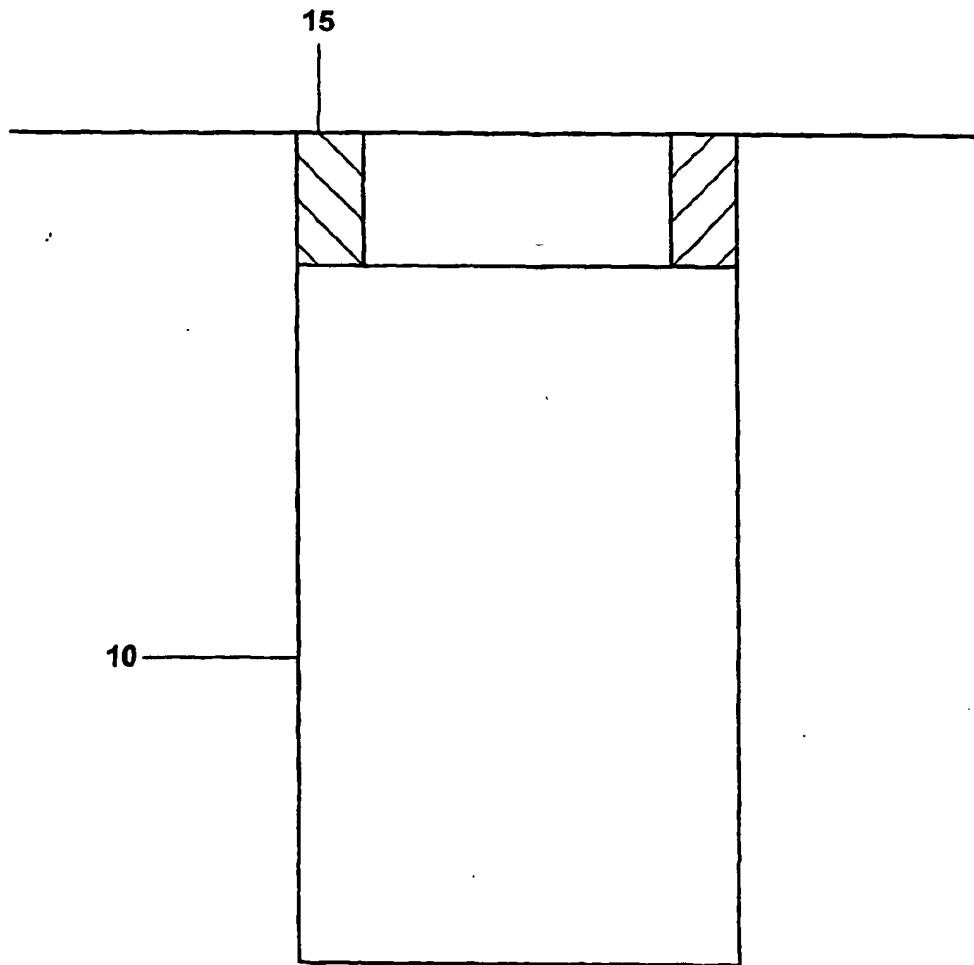

Fig. 6a

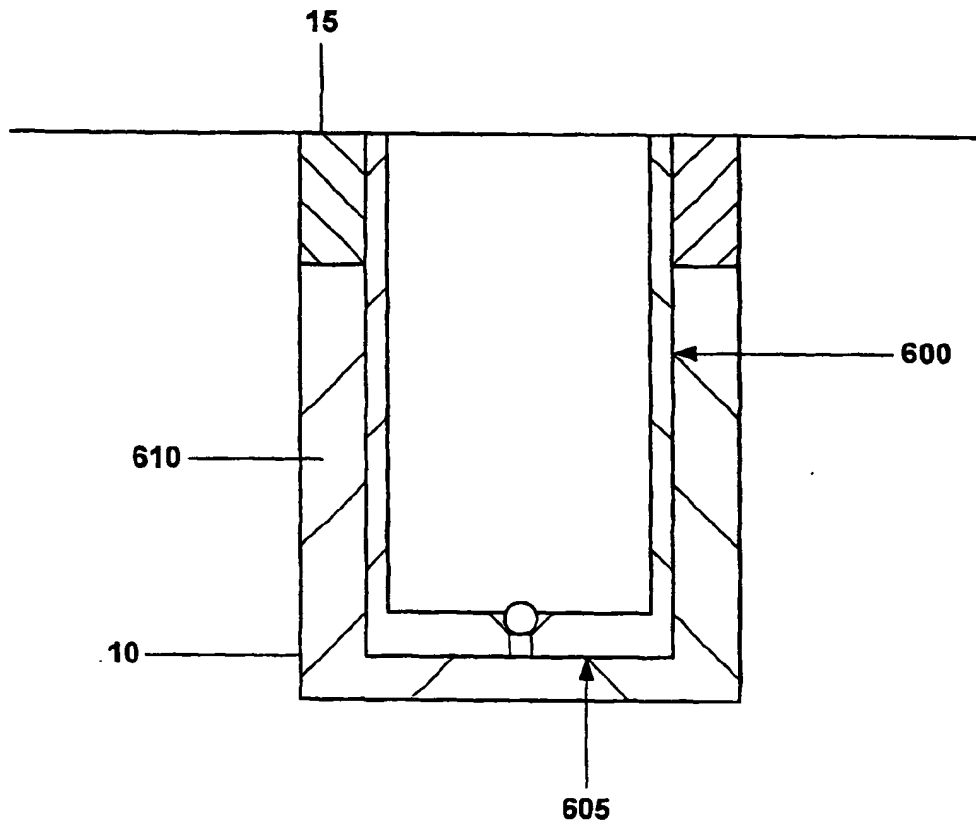

Fig. 6b

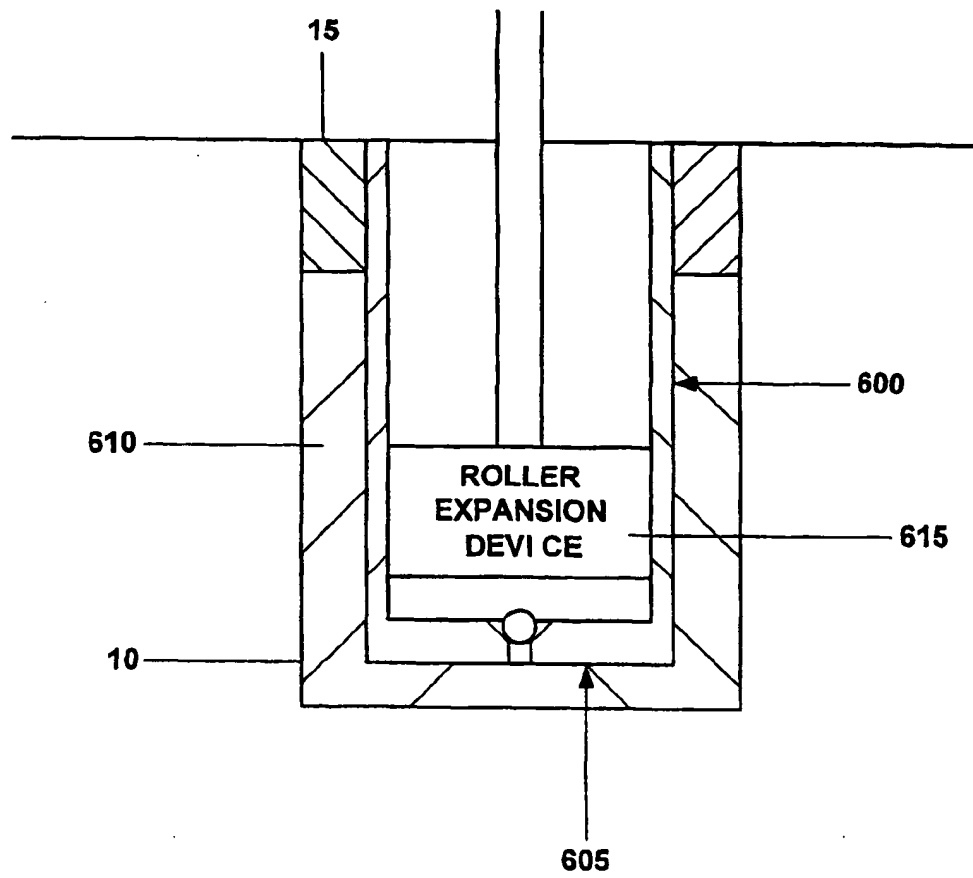

Fig. 6c

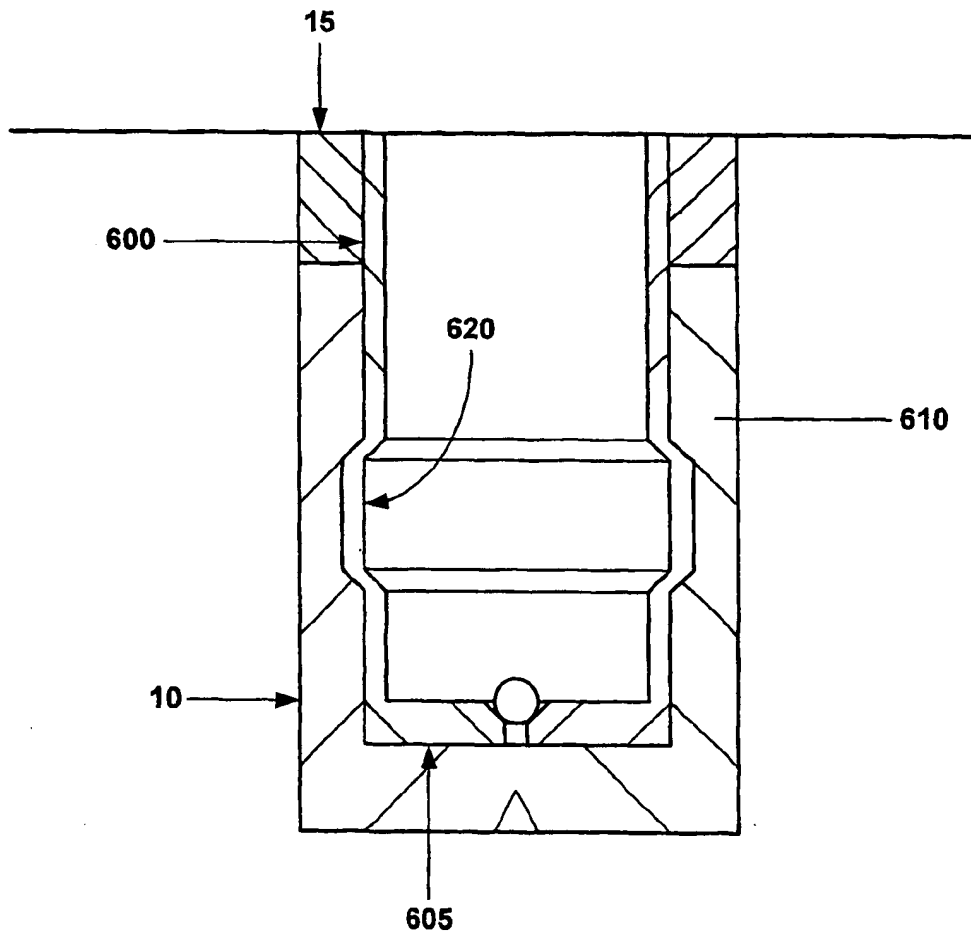

Fig. 6d

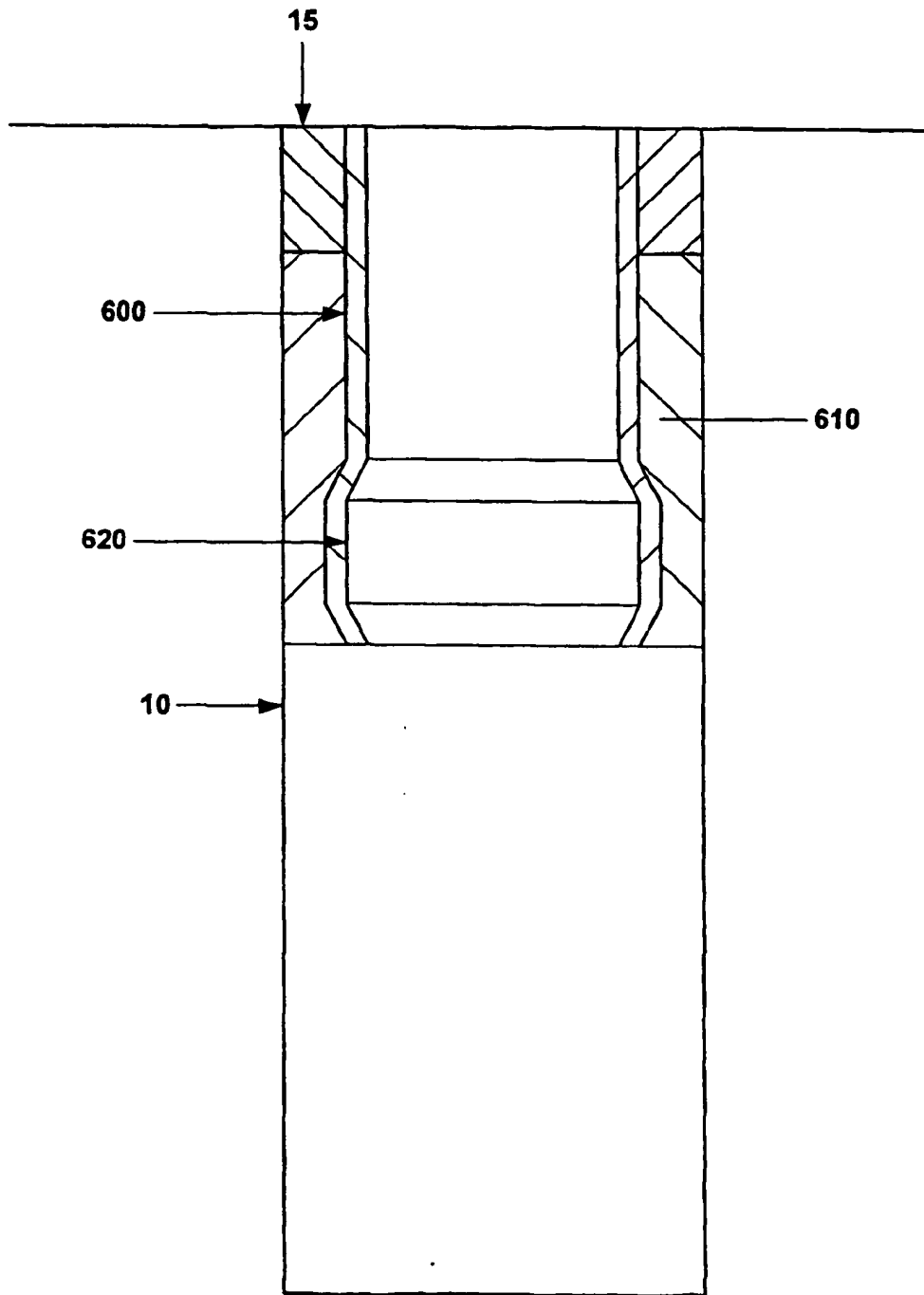

Fig. 6e

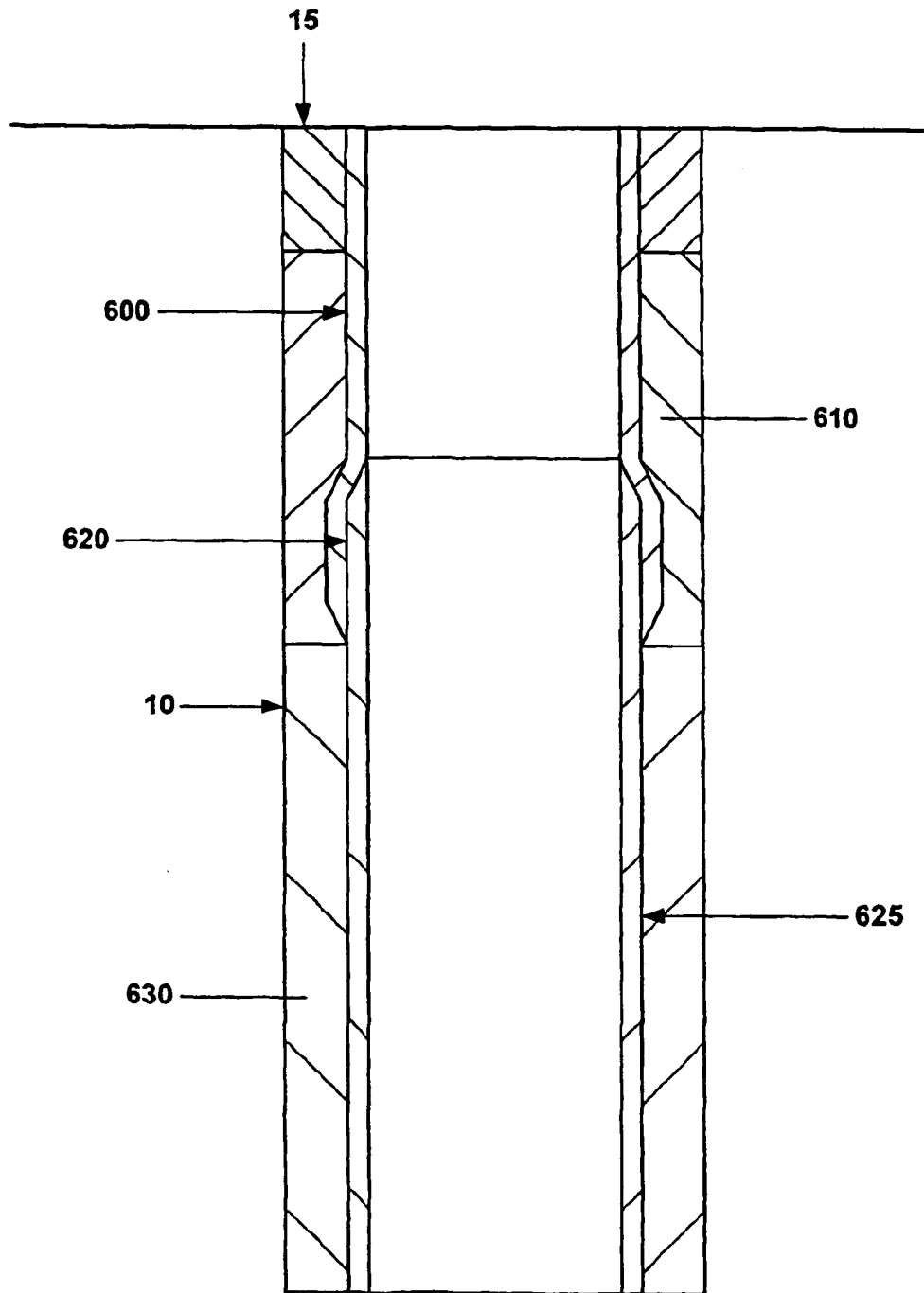

Fig. 6f

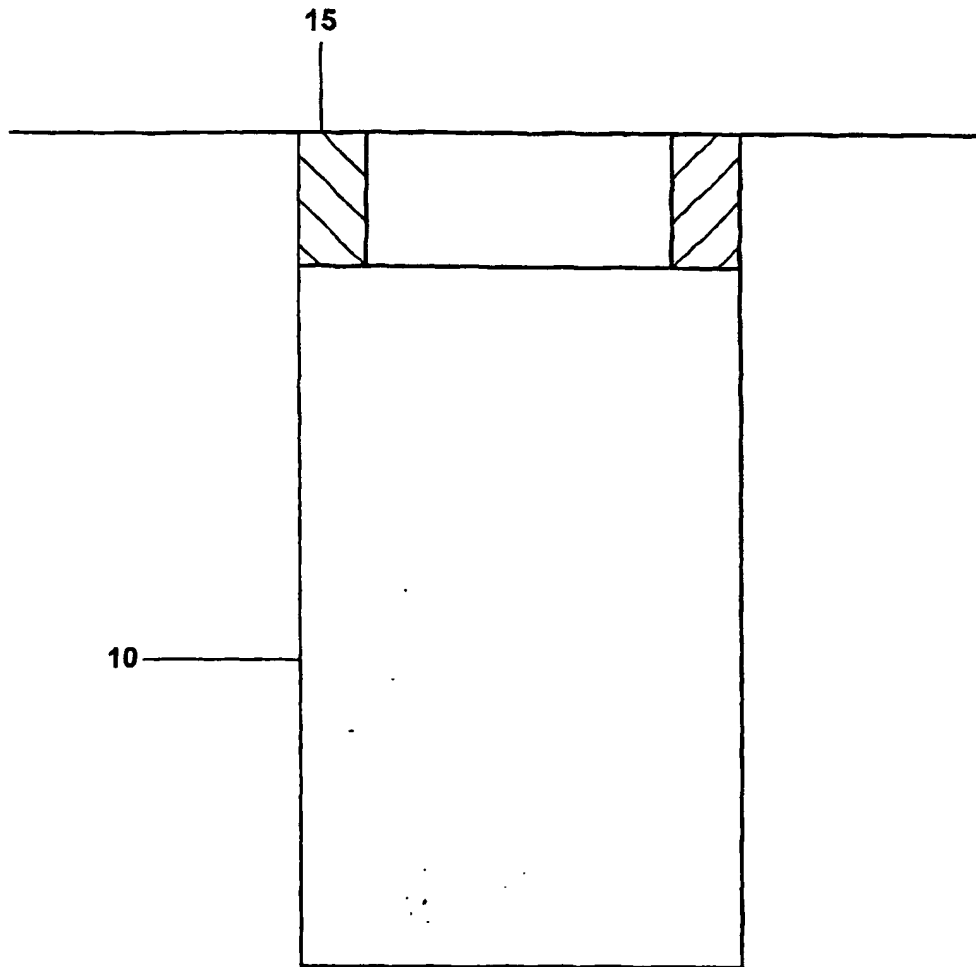

Fig. 7a

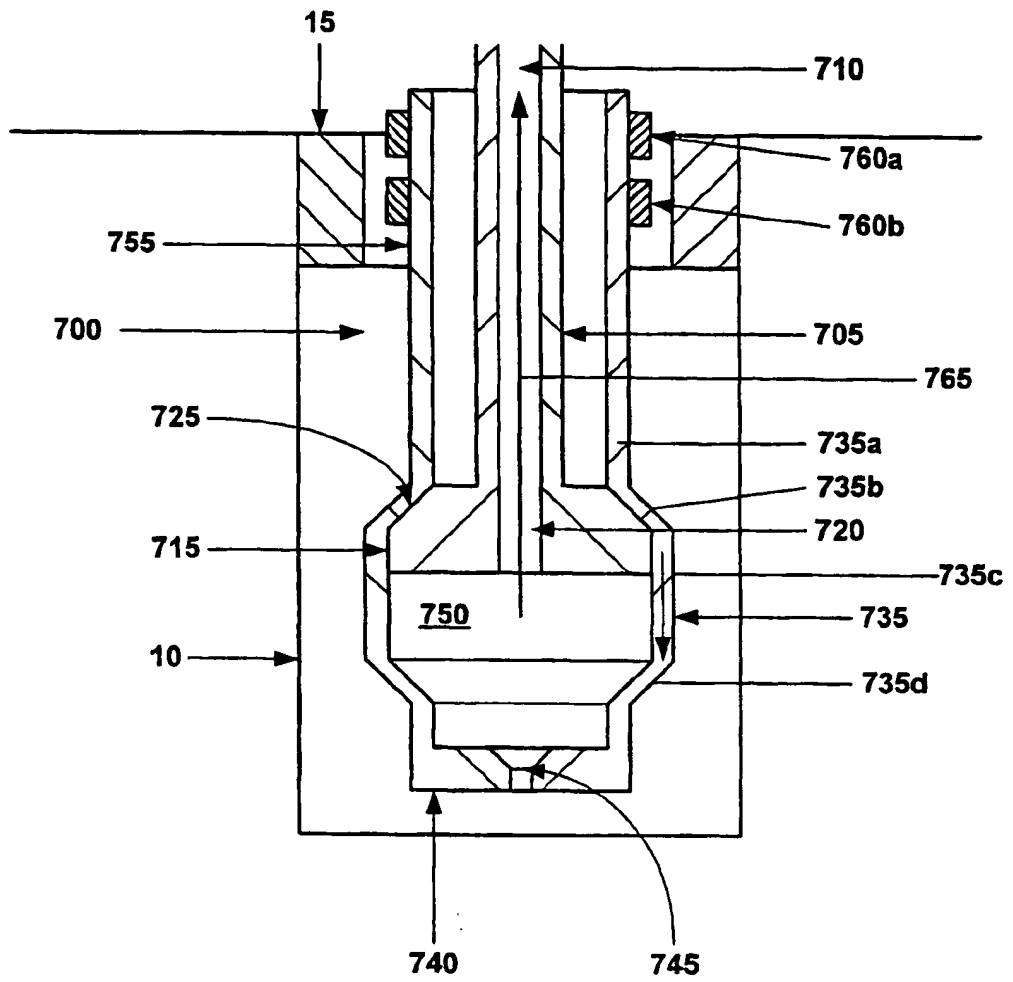

Fig. 7b

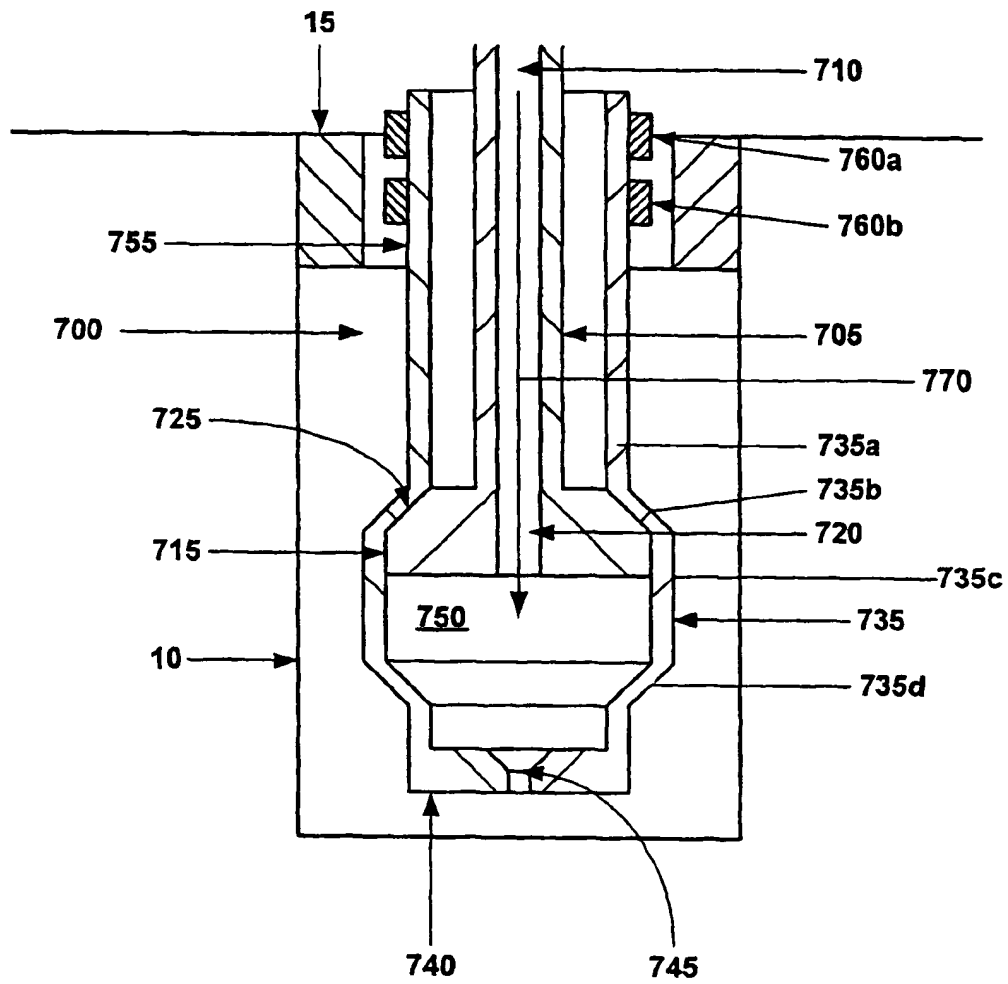

Fig. 7c

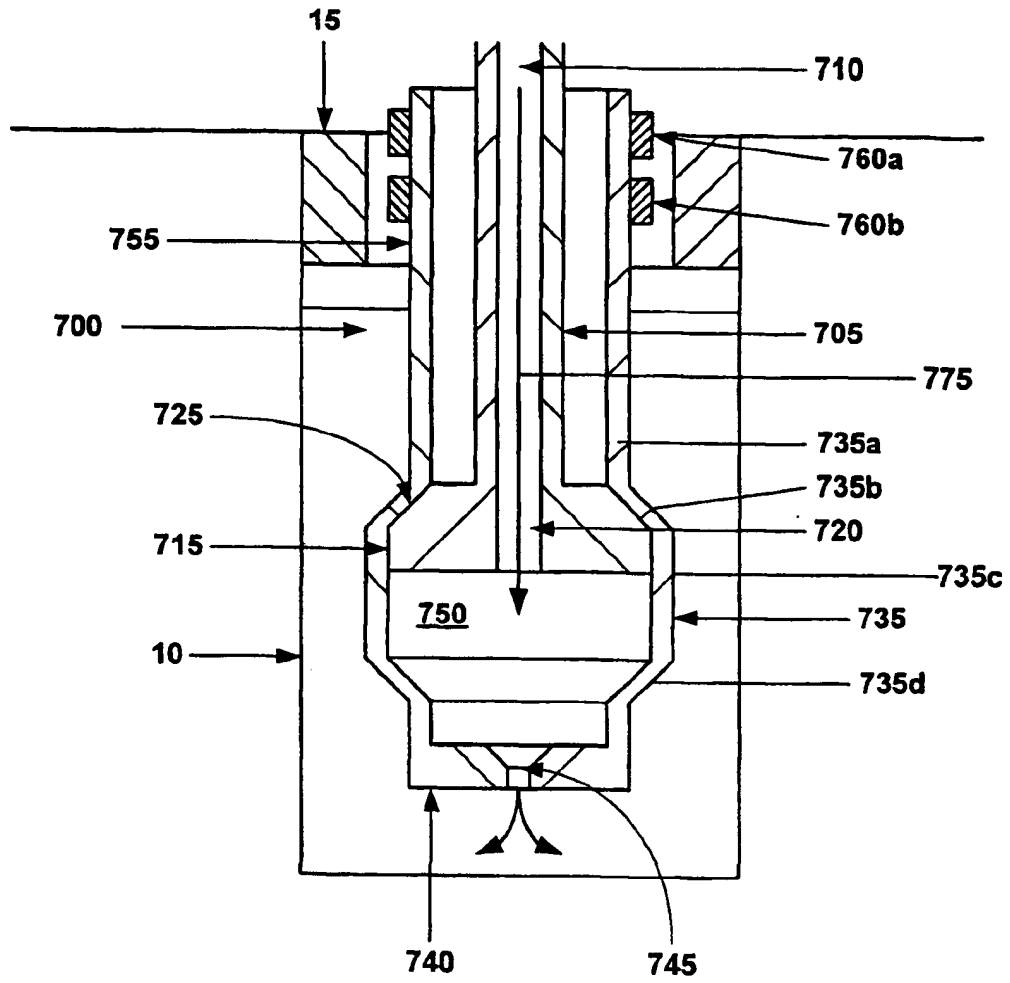

Fig. 7d

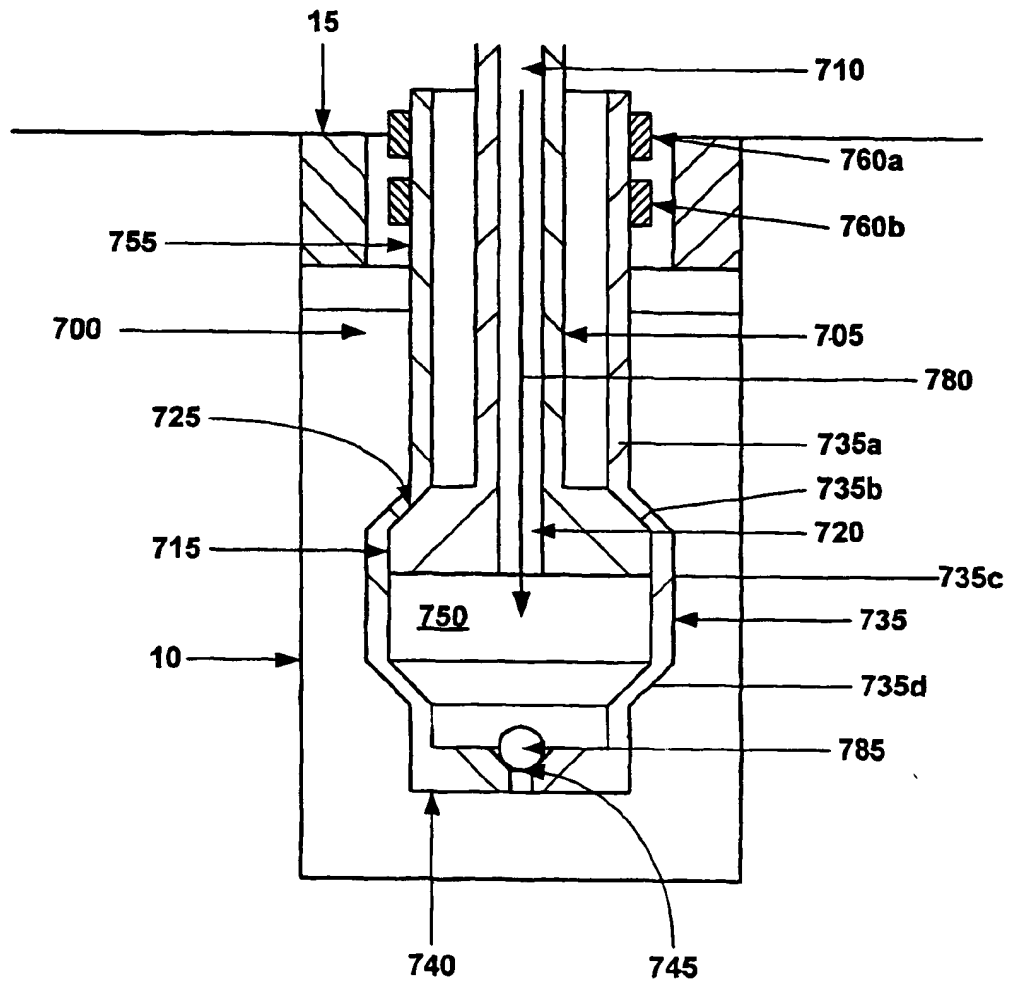

Fig. 7

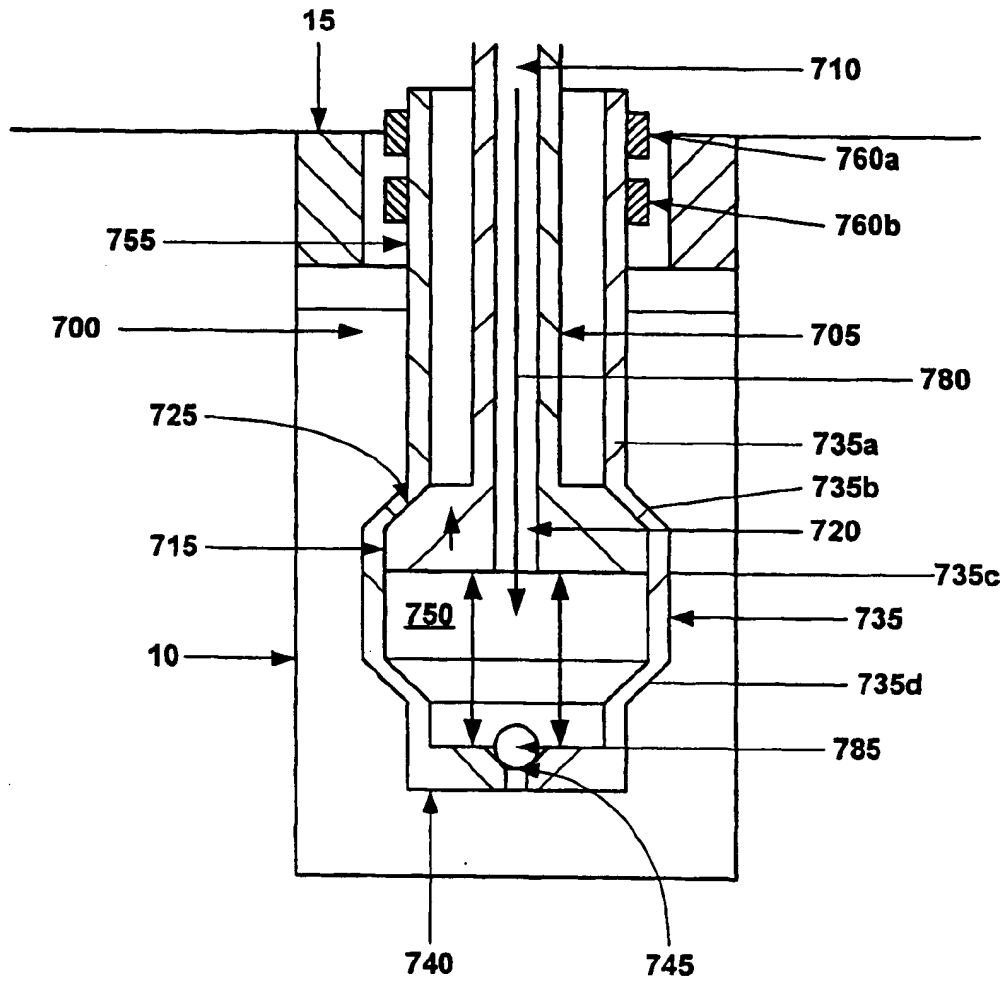

Fig. 7f

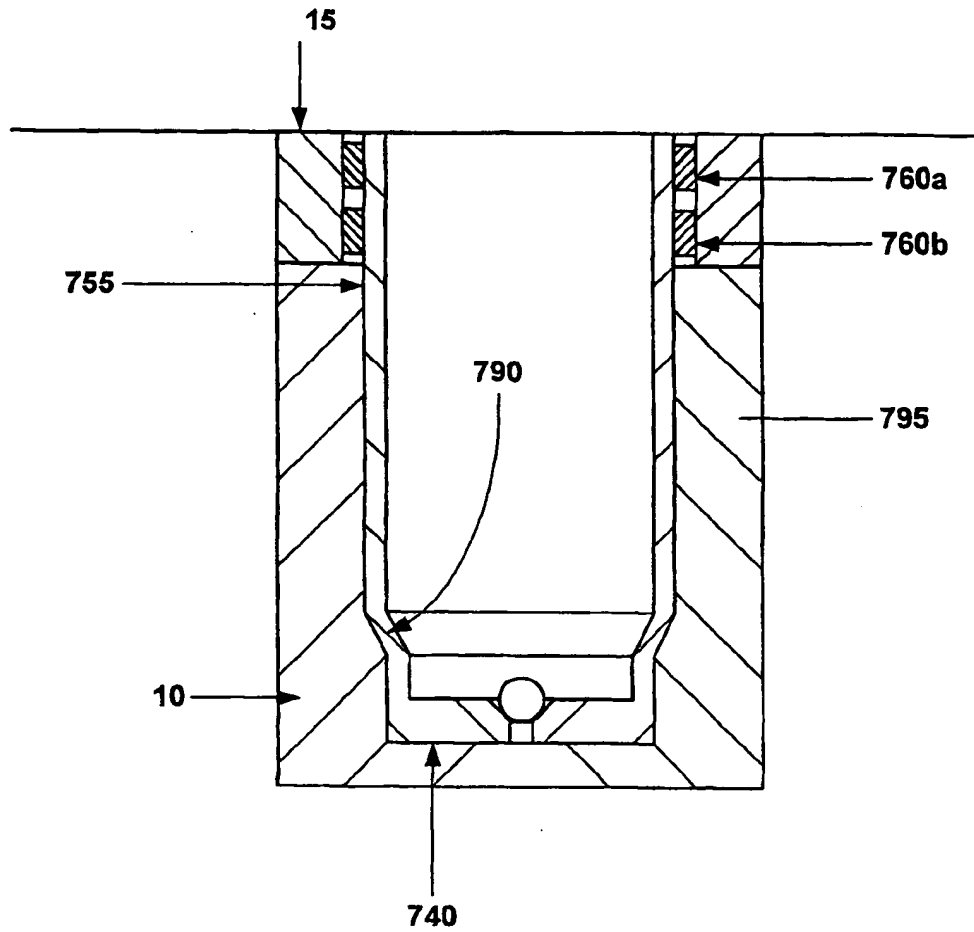

Fig. 7g

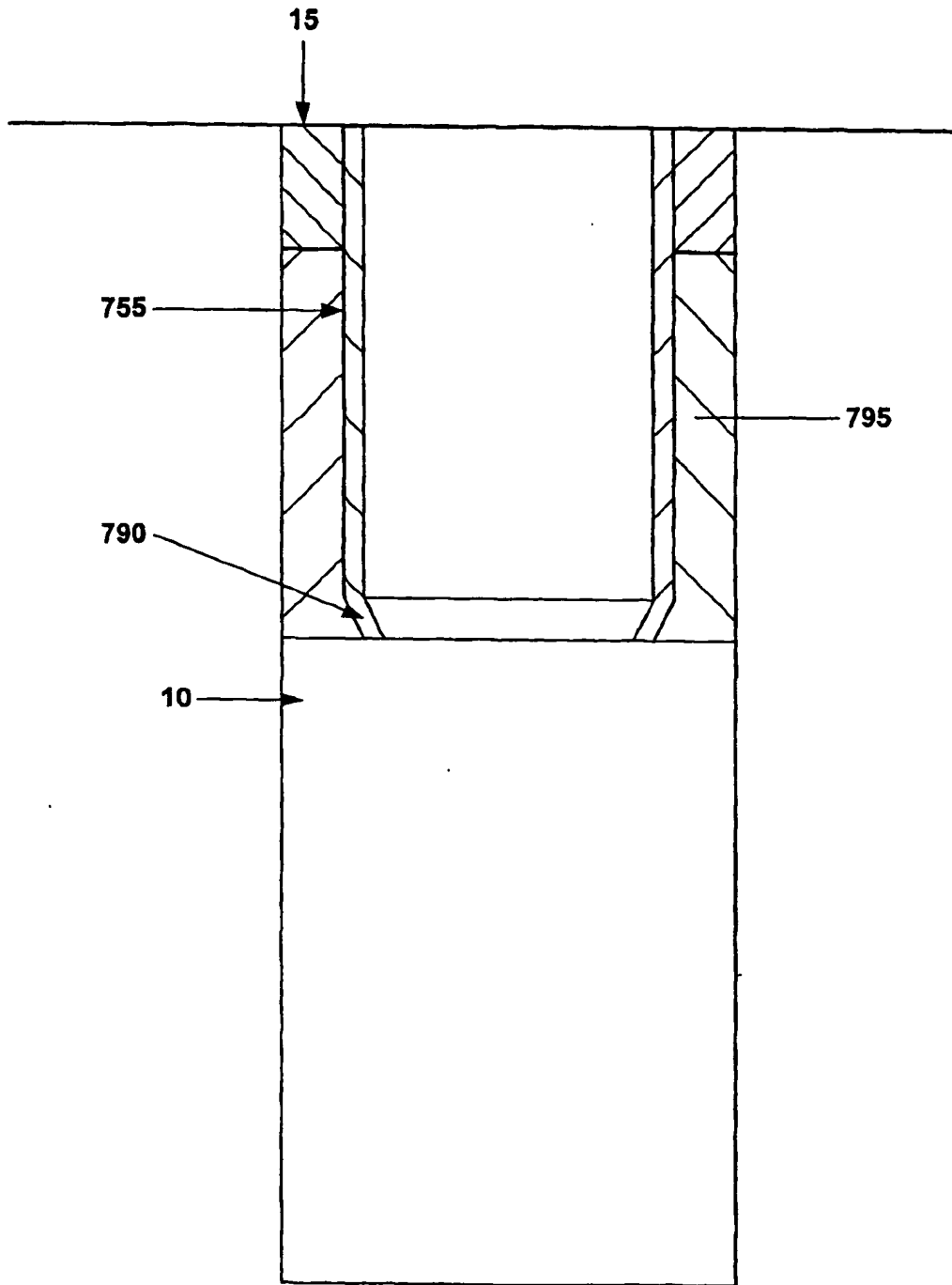

Fig. 7h

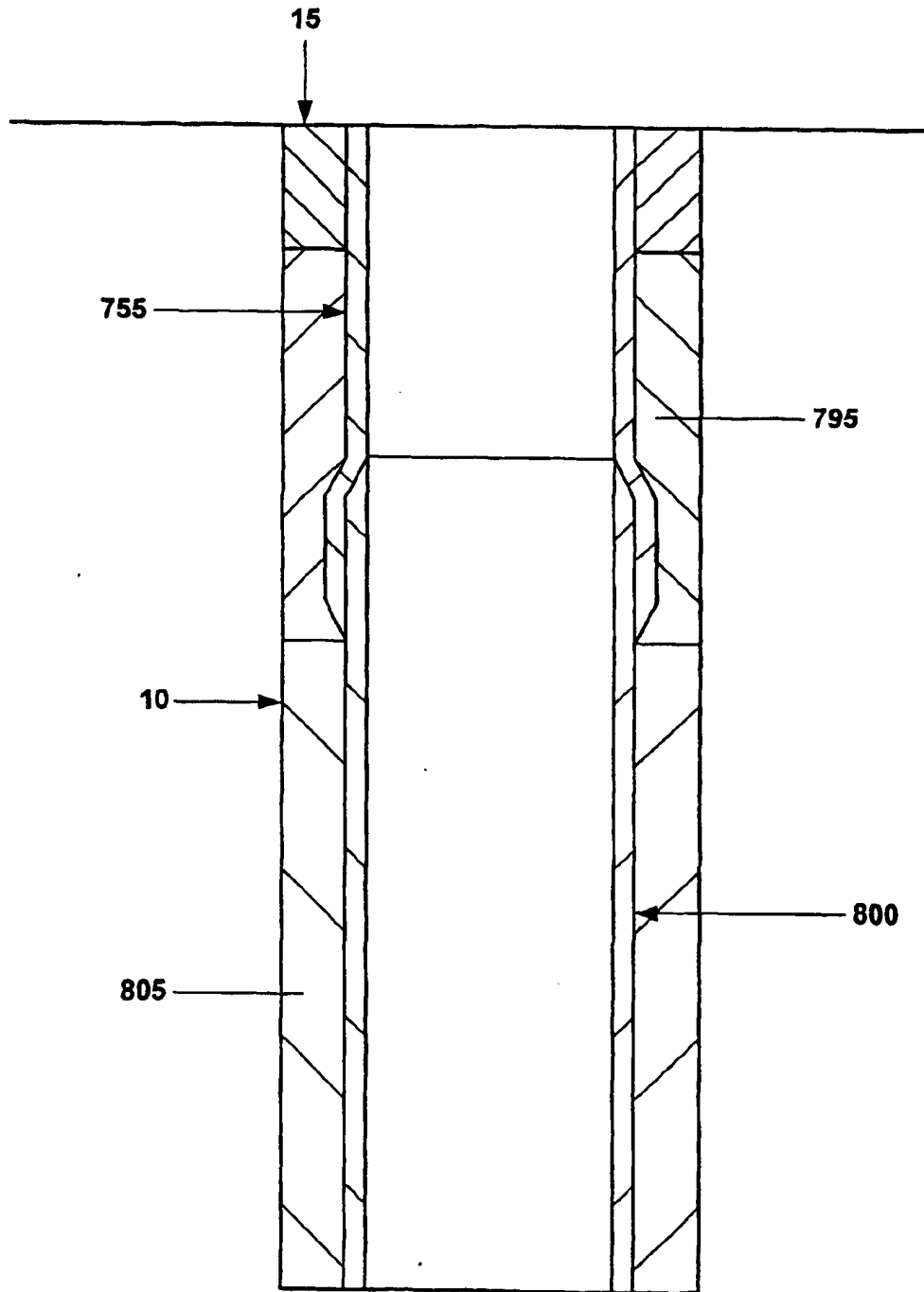

Fig. 7i

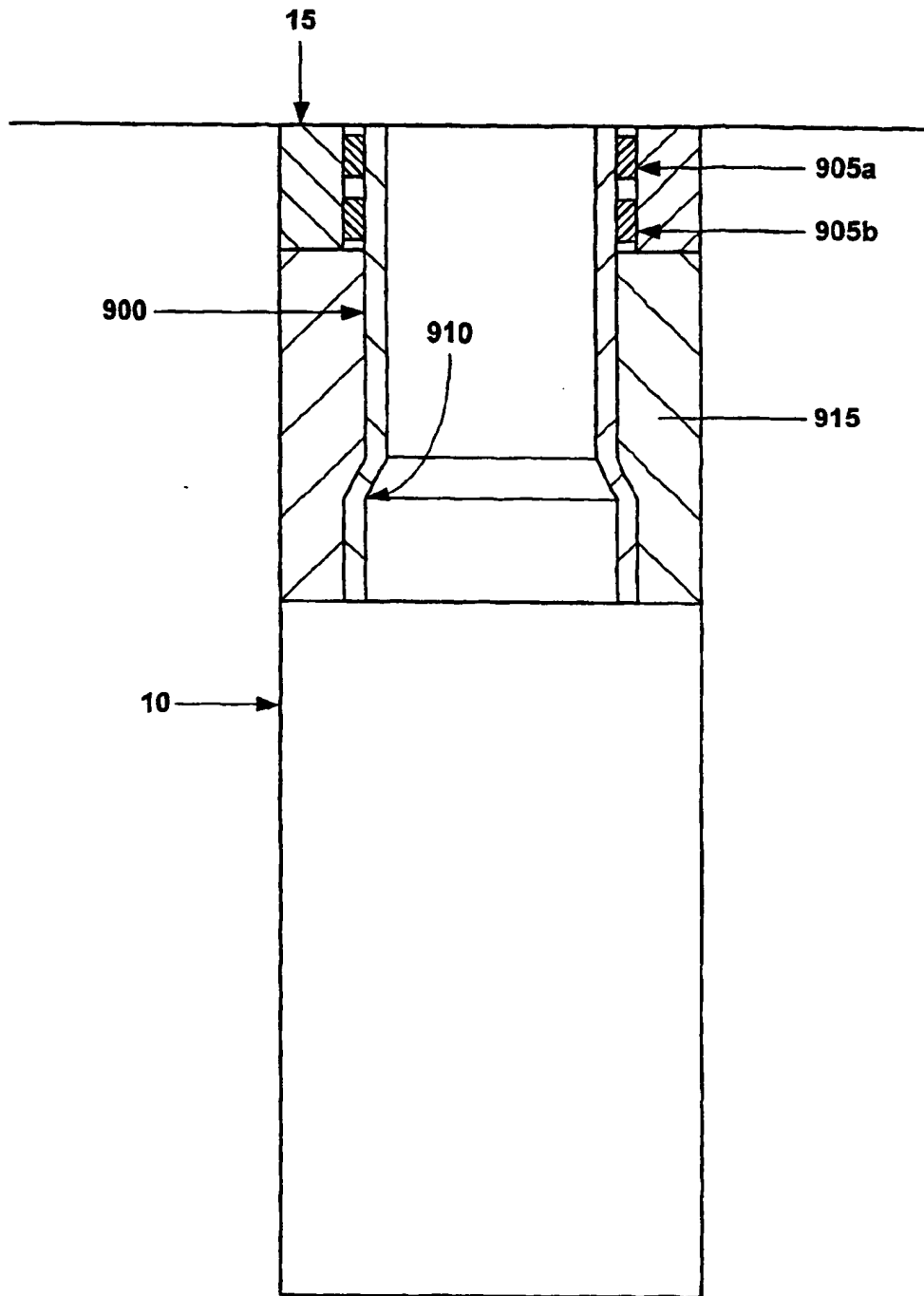

Fig. 8a

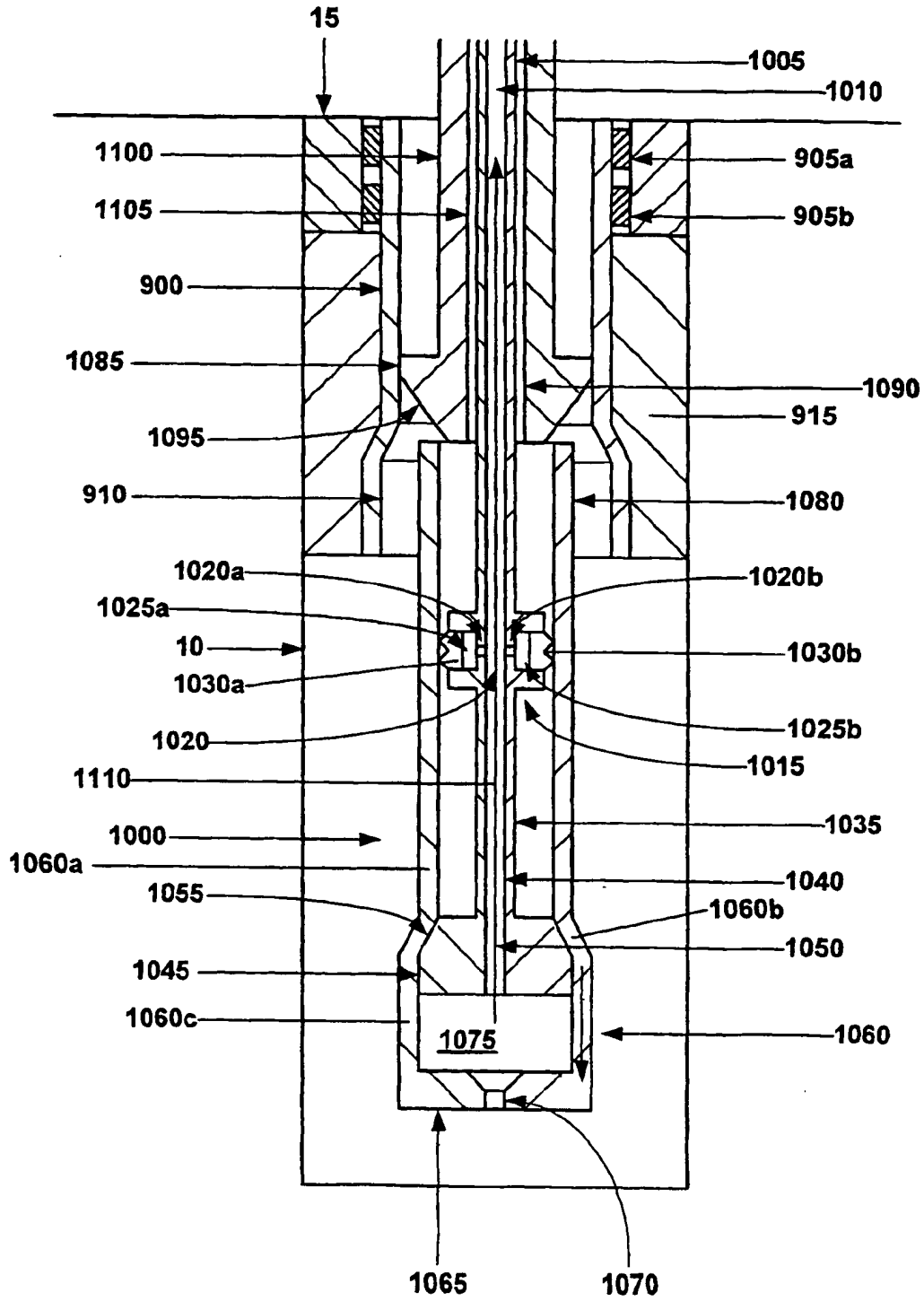

Fig. 8b

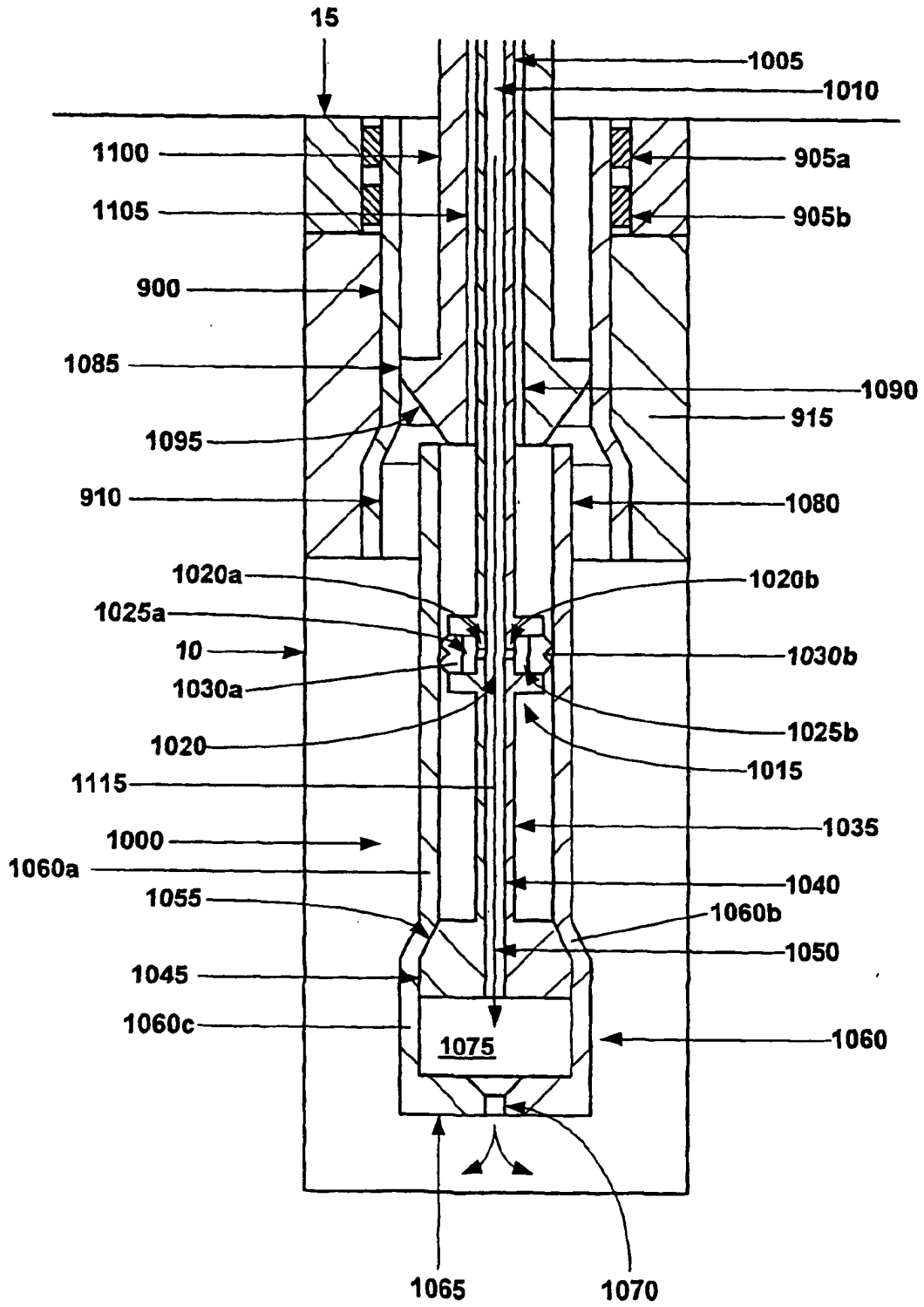

Fig. 8c

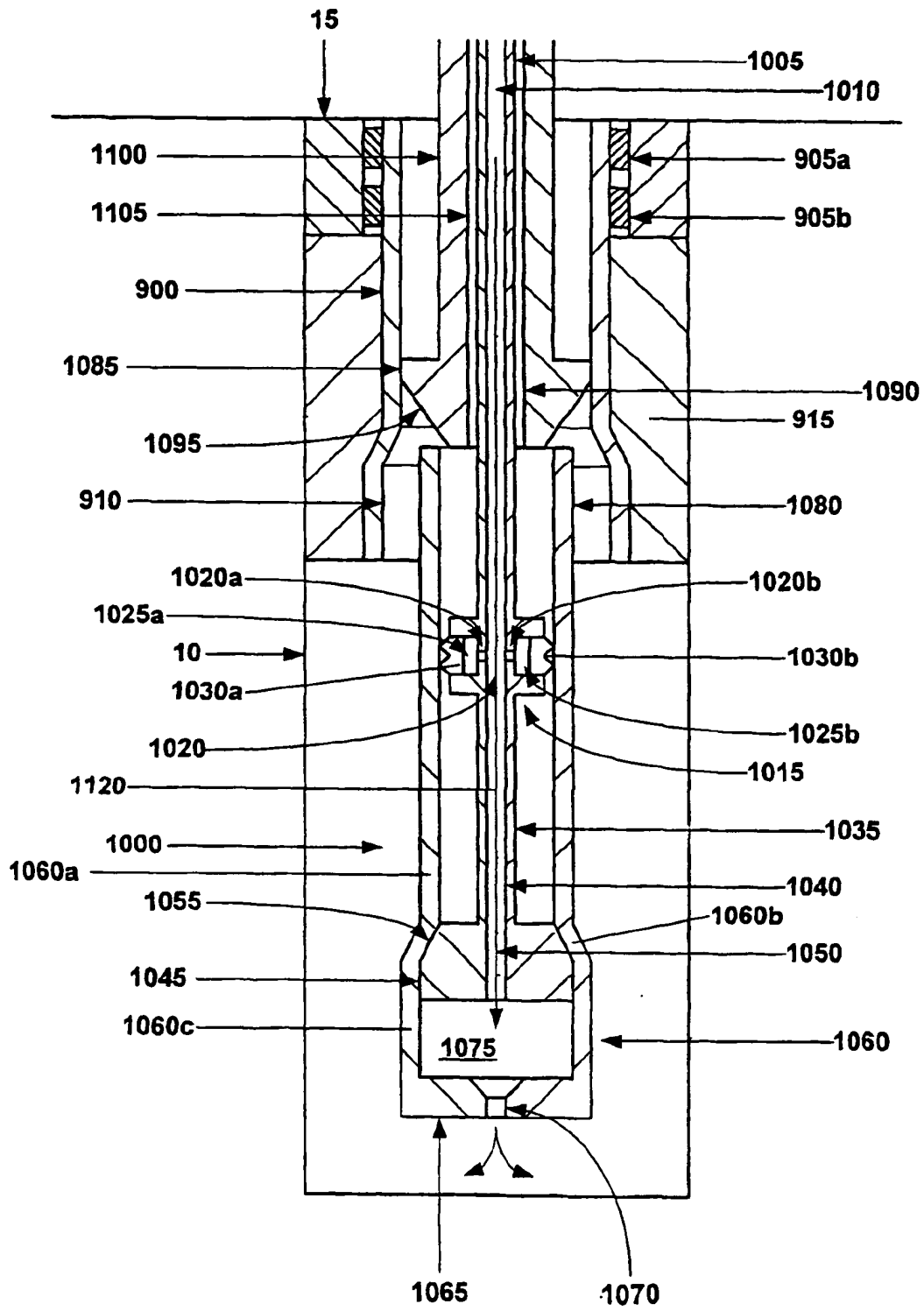

Fig. 8d

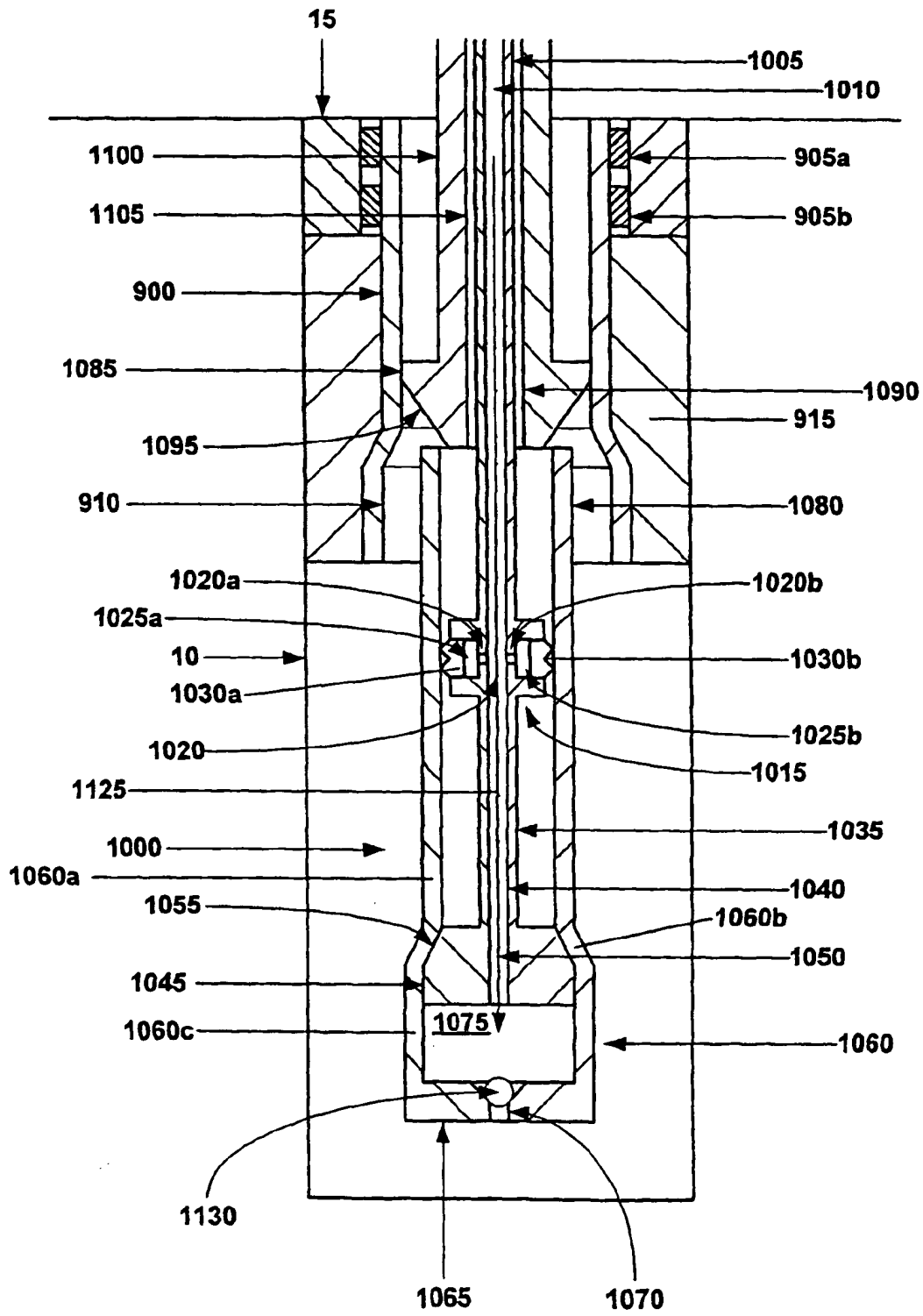

Fig. 8e

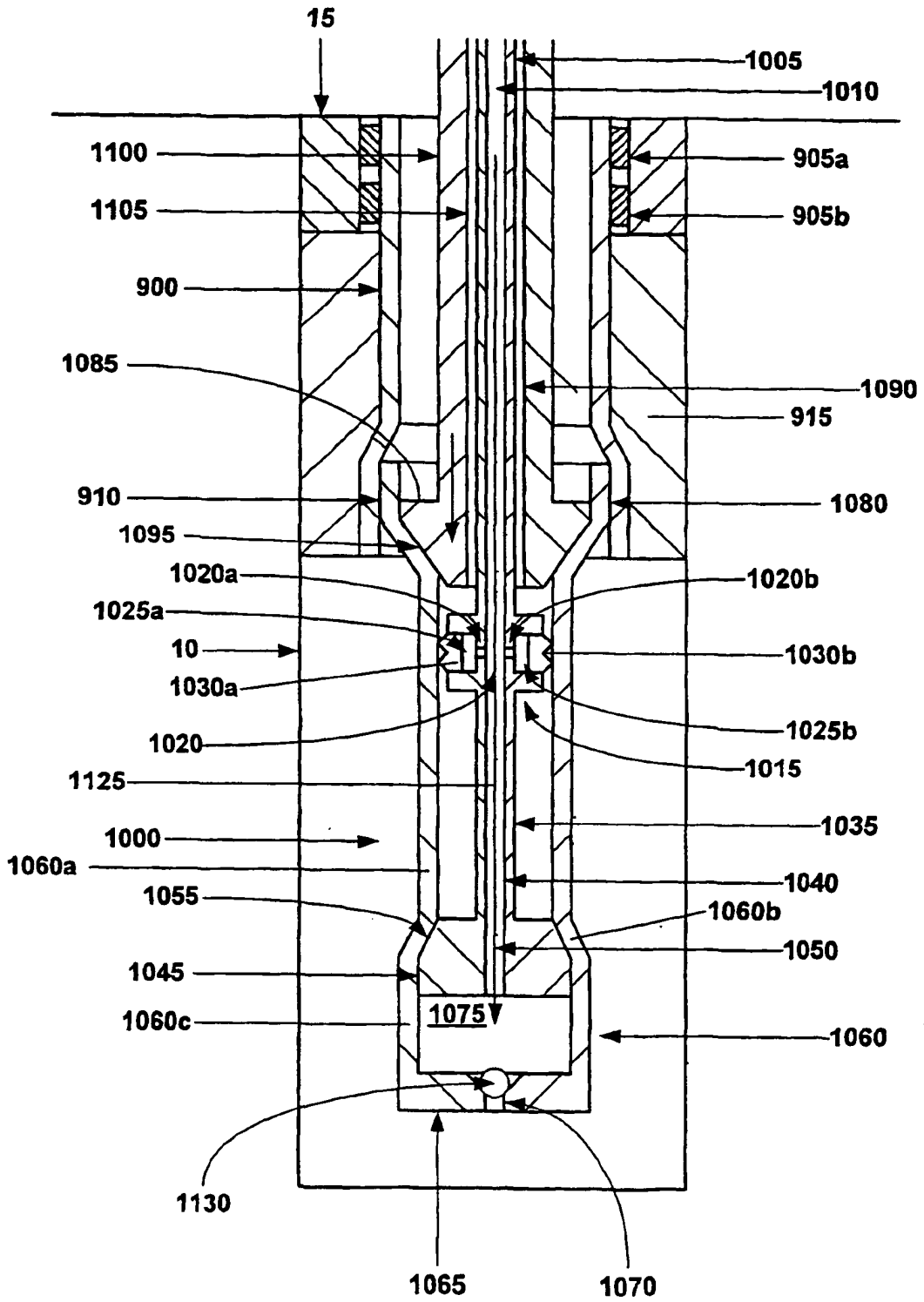

Fig. 8f

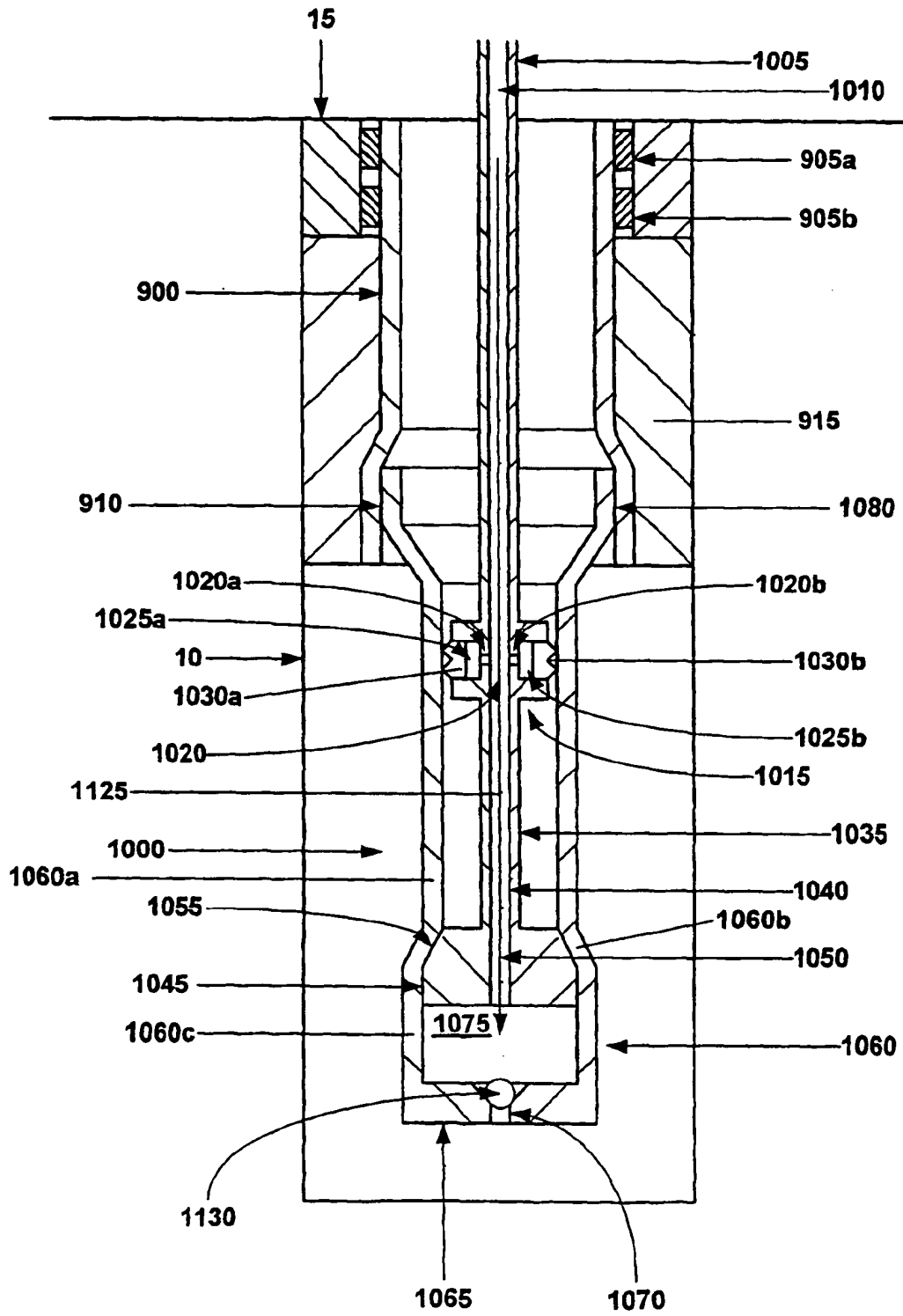

Fig. 8g

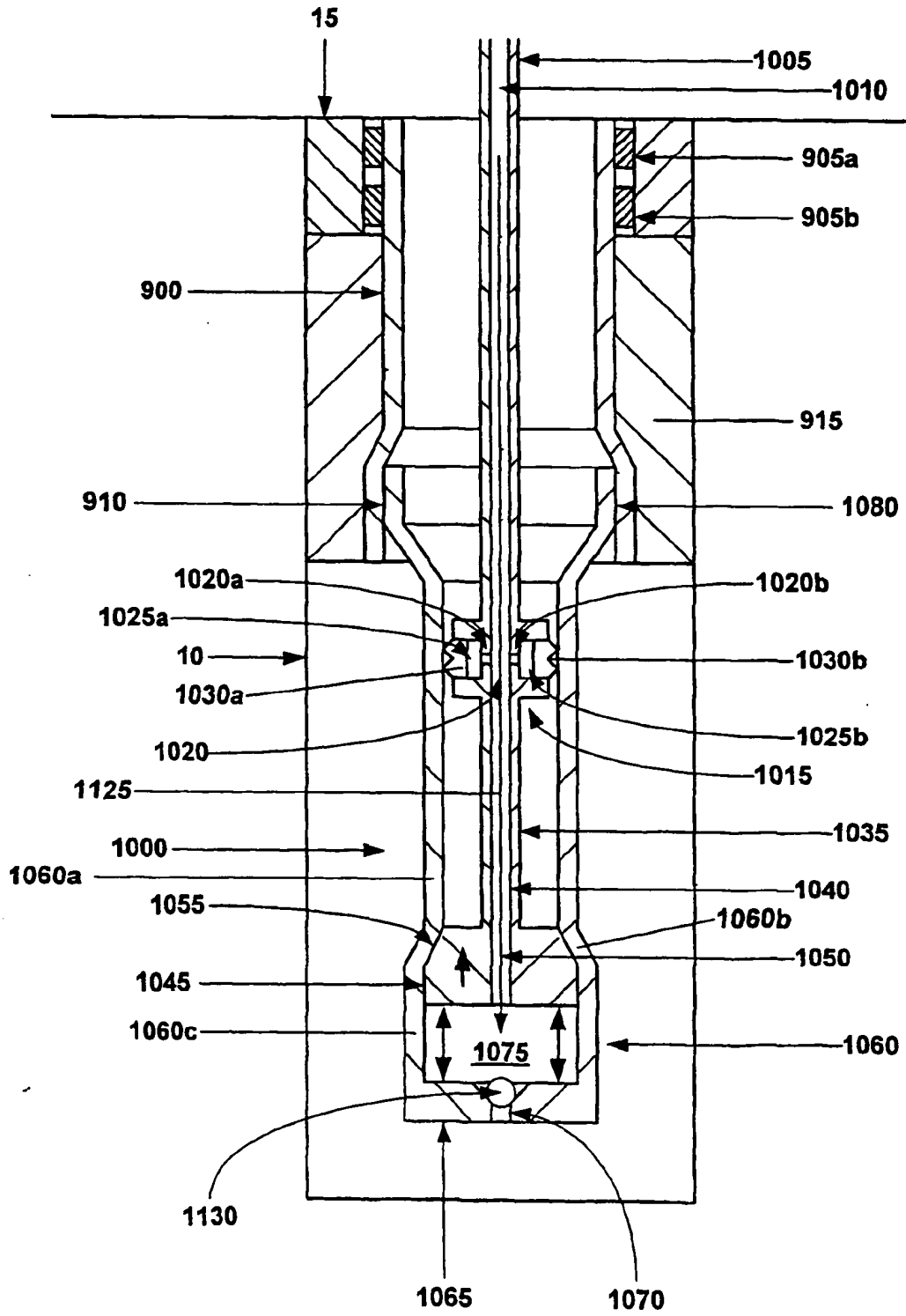

Fig. 8h

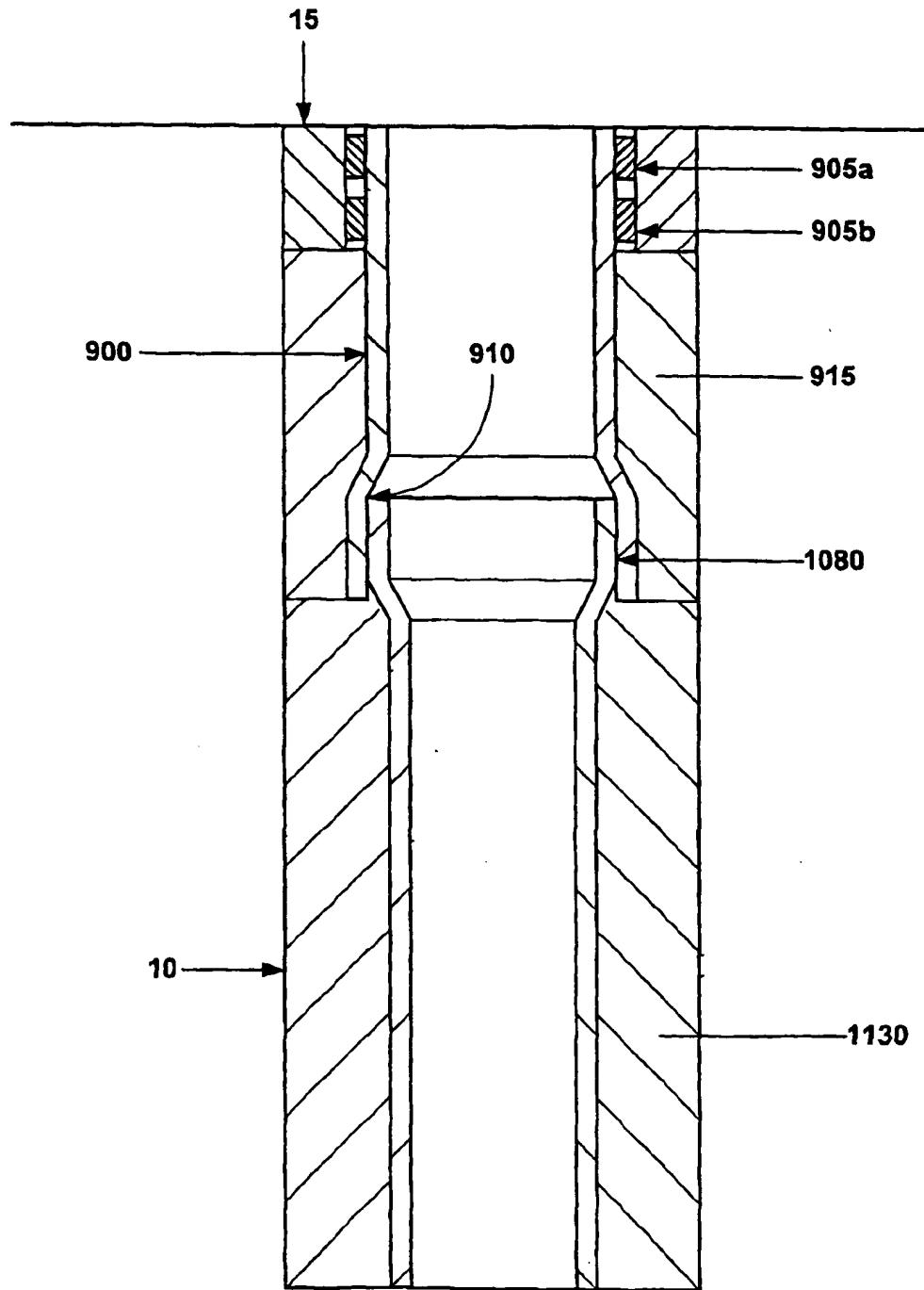

Fig. 8i

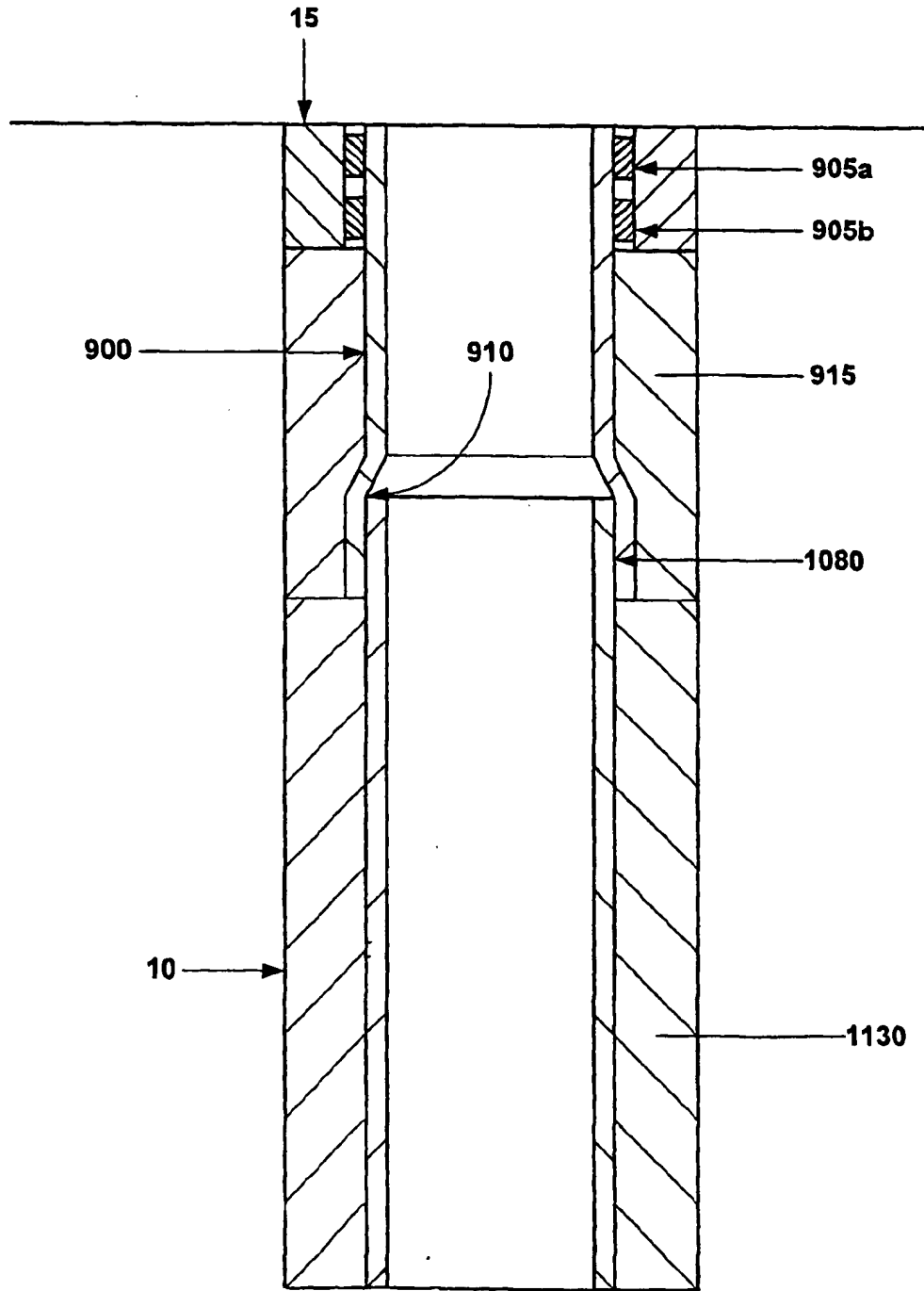

Fig. 8j

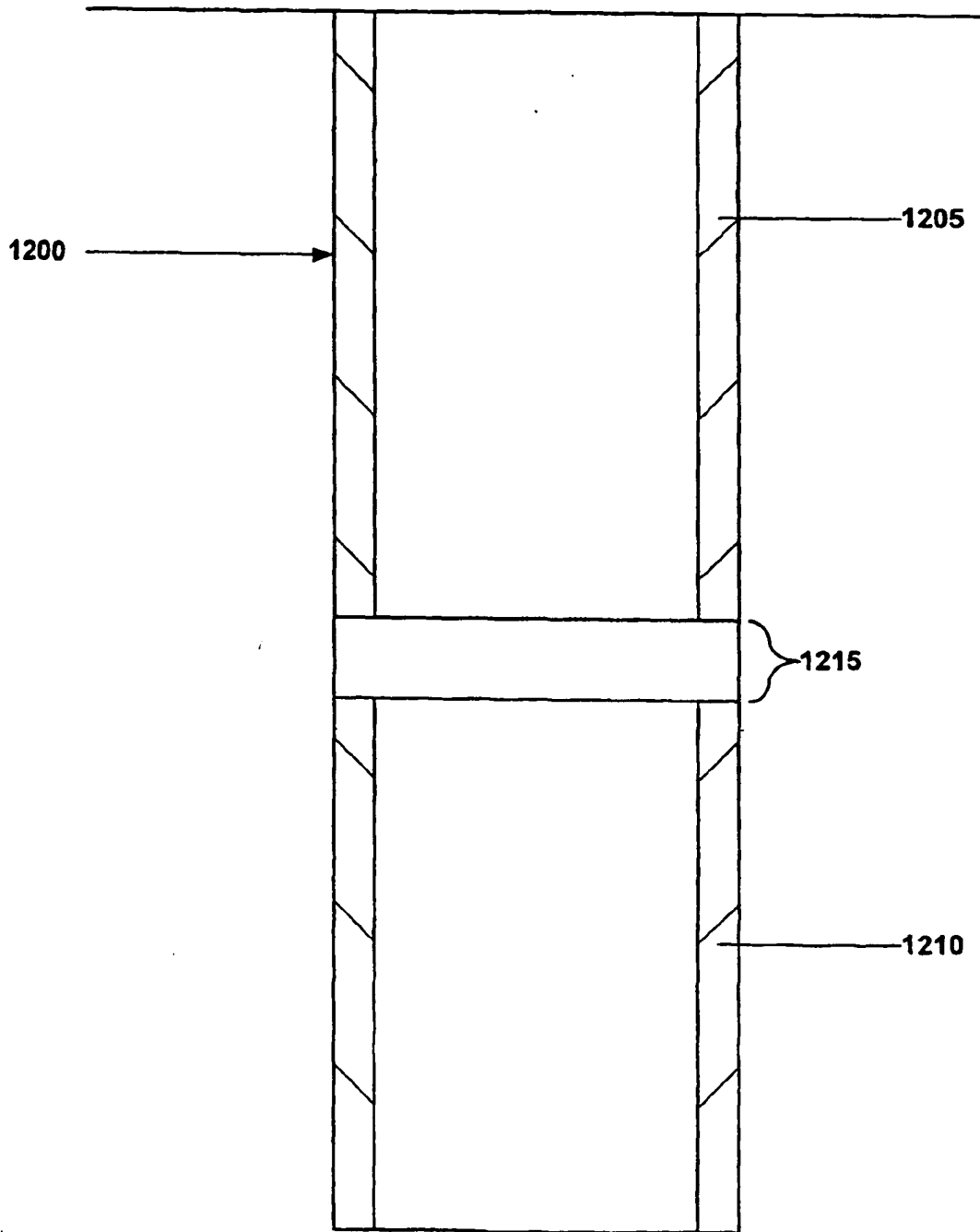

Fig. 9a

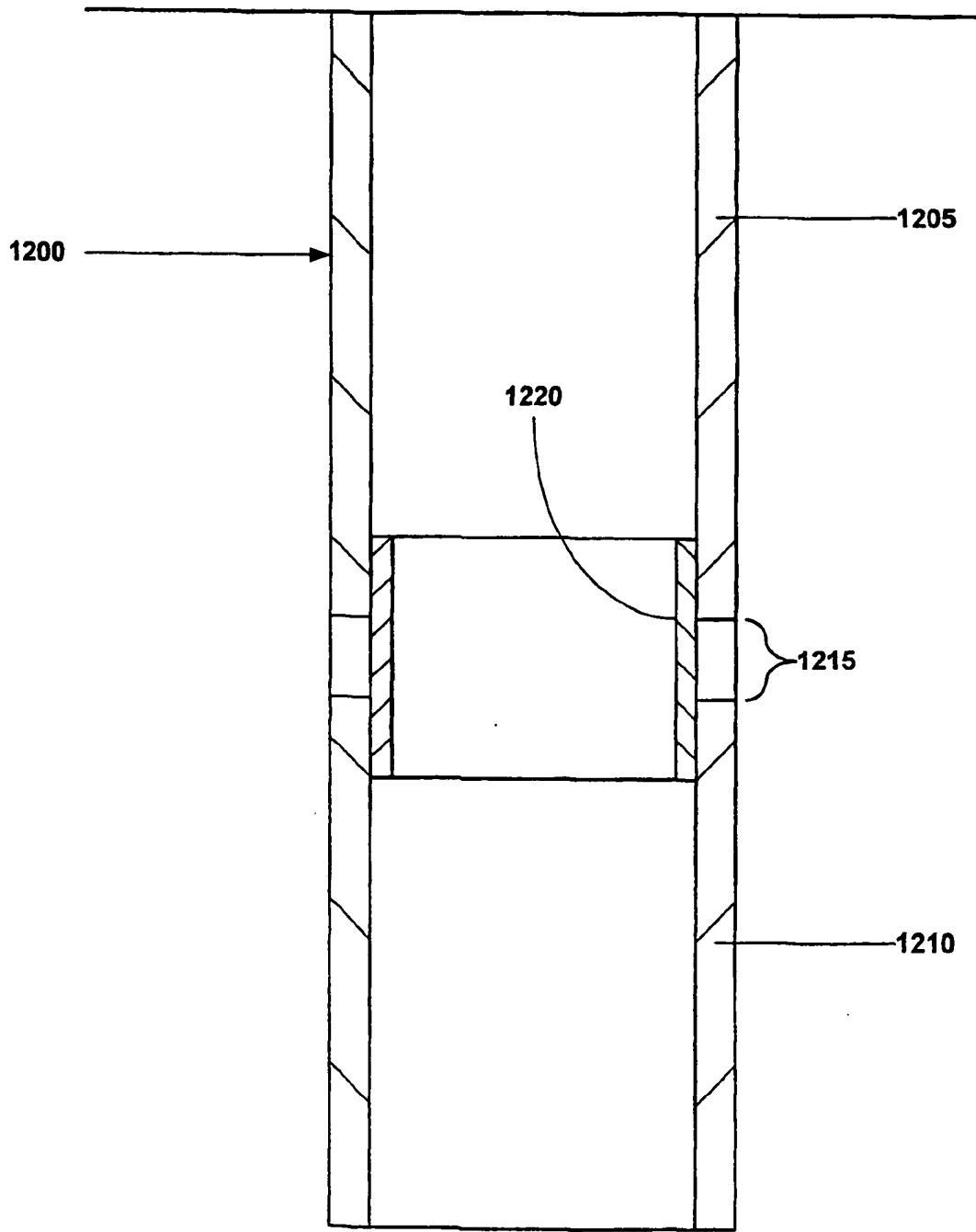

Fig. 9b

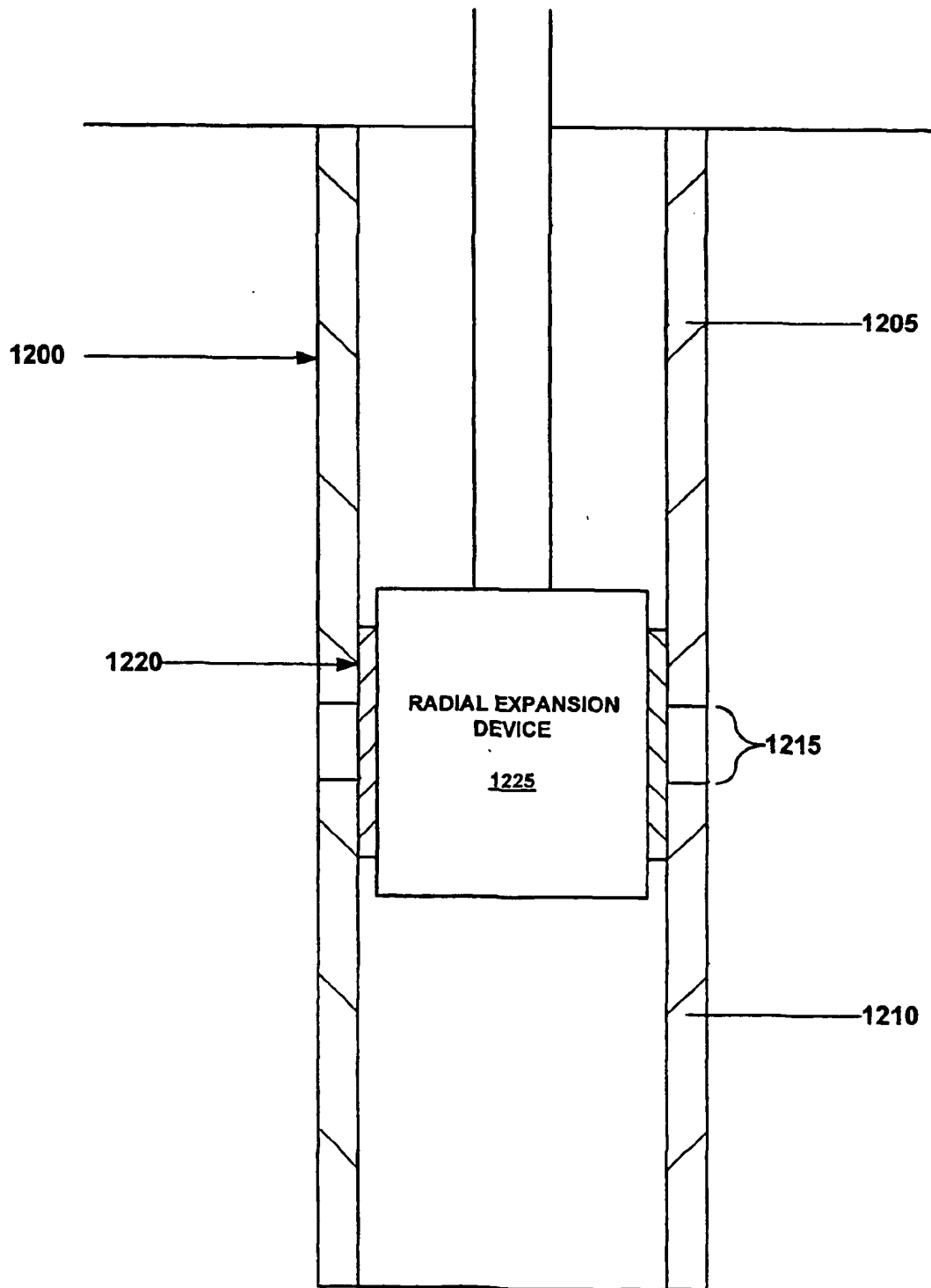

Fig. 9c

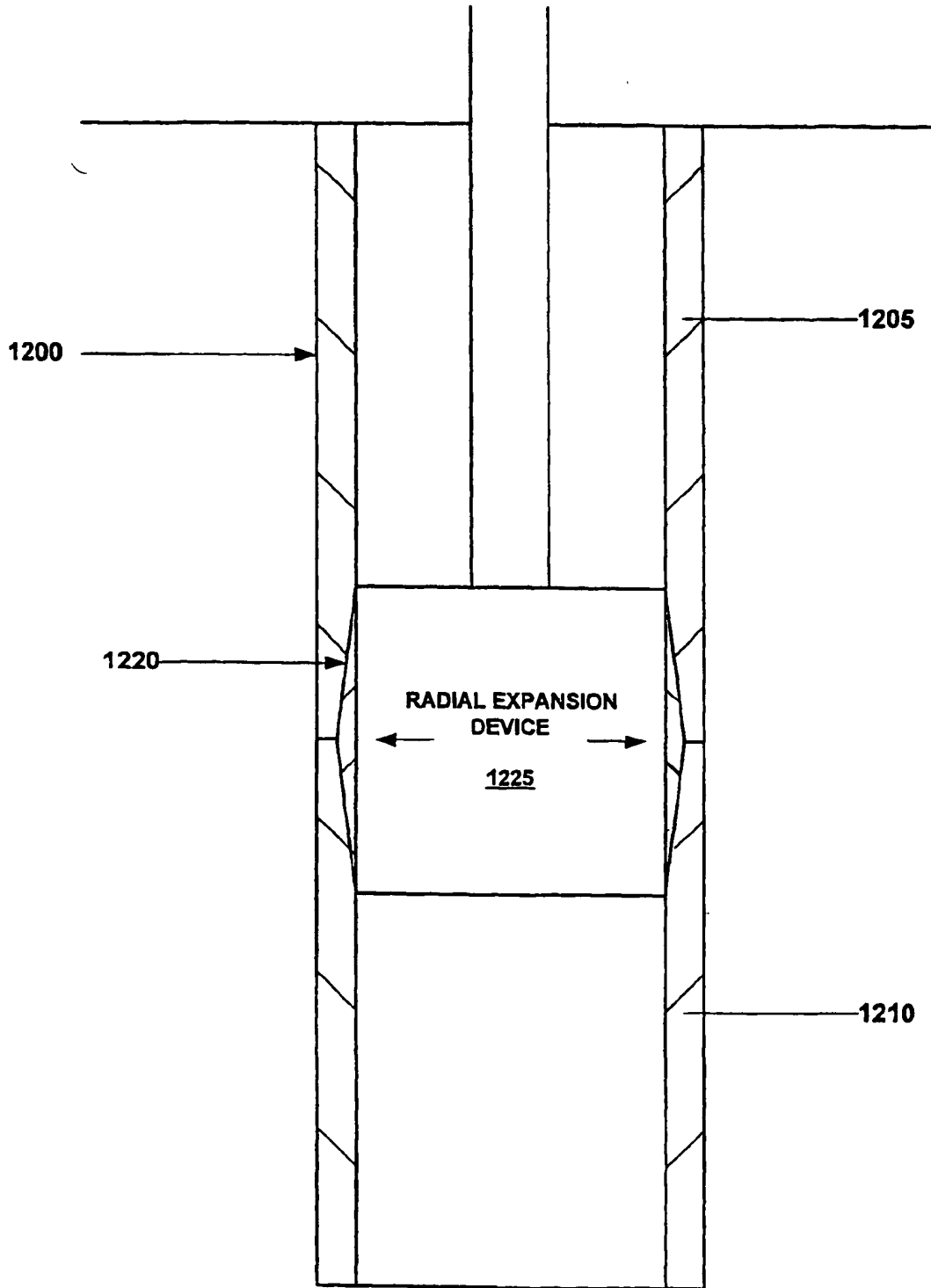

Fig. 9d

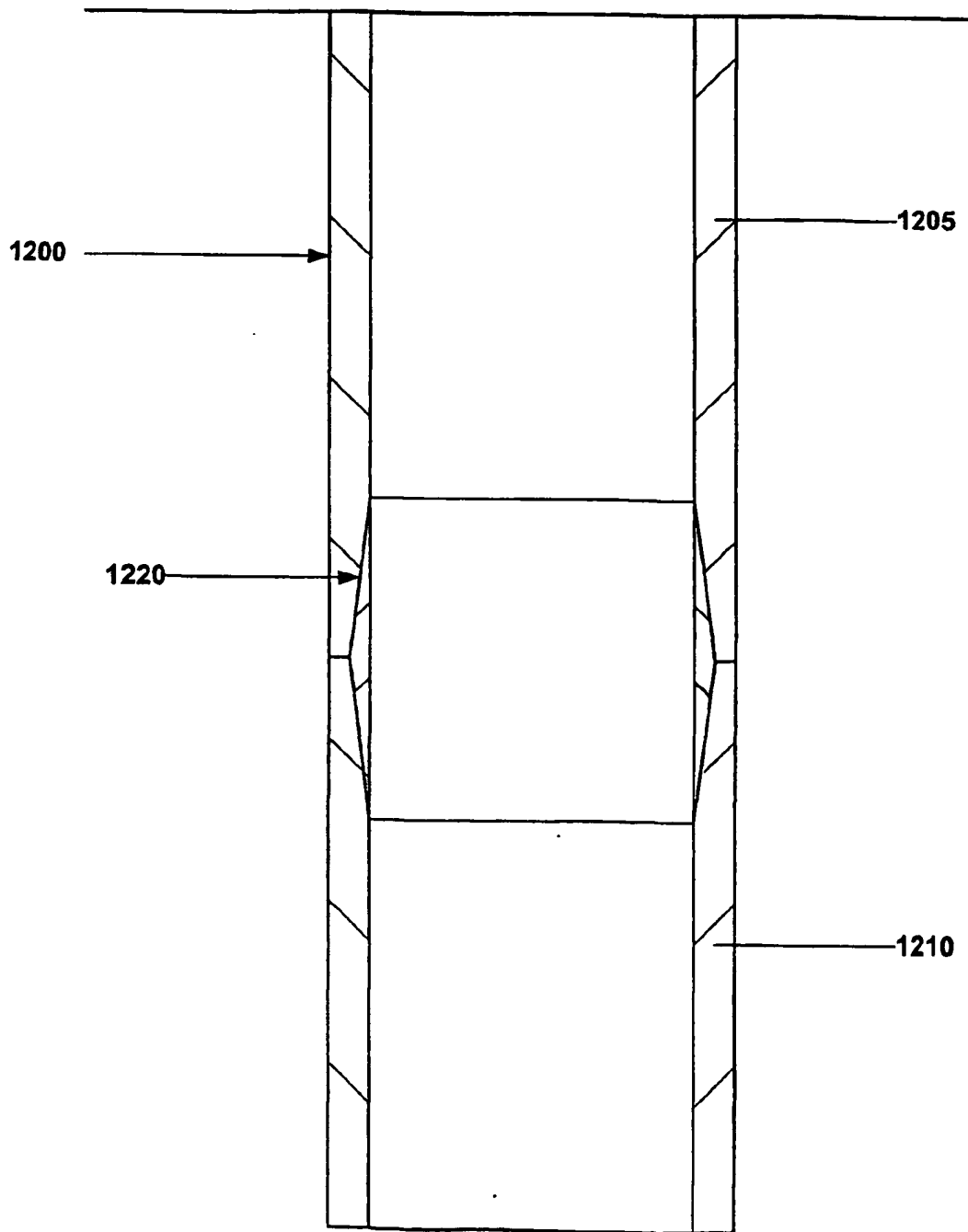

Fig. 9e

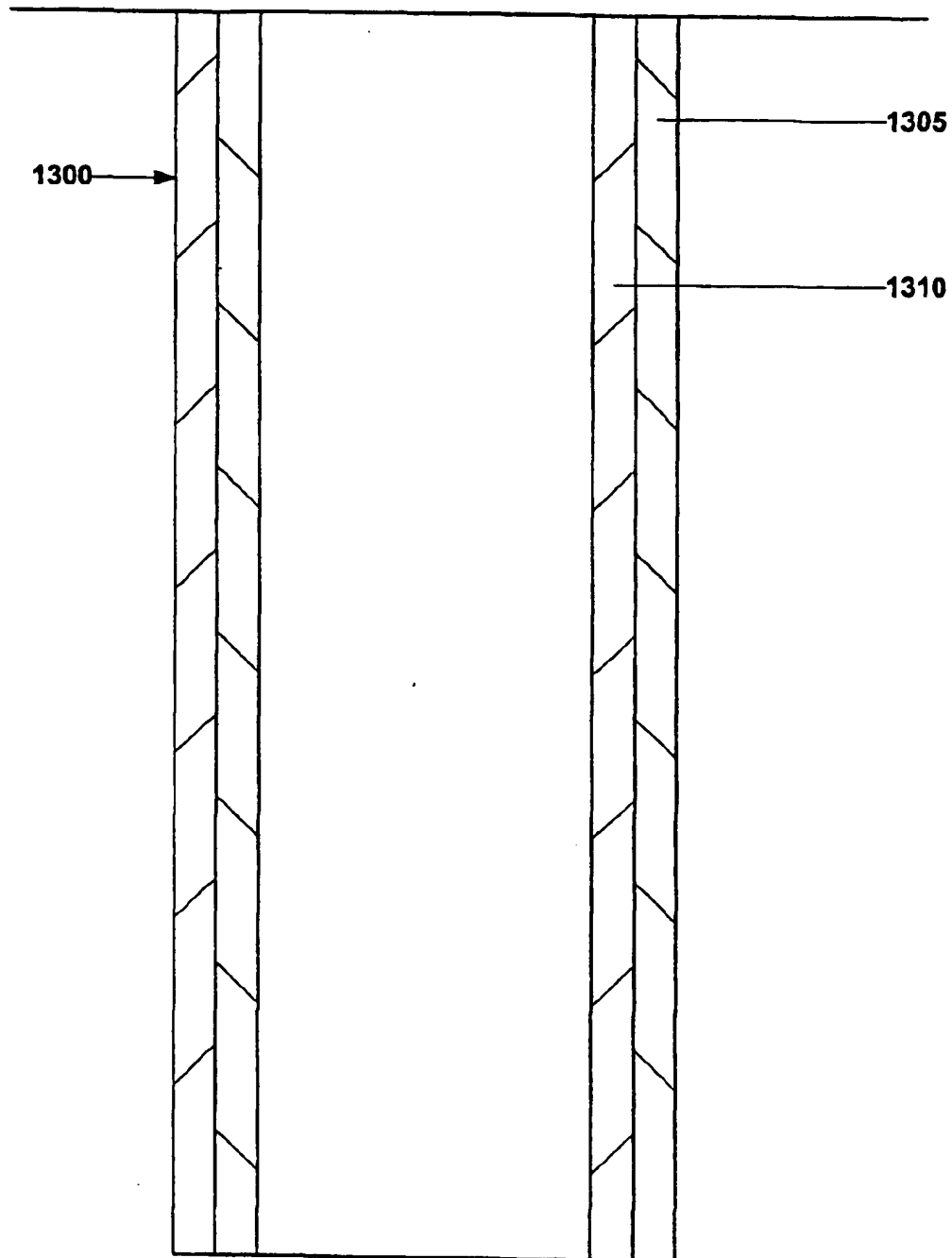

Fig. 10

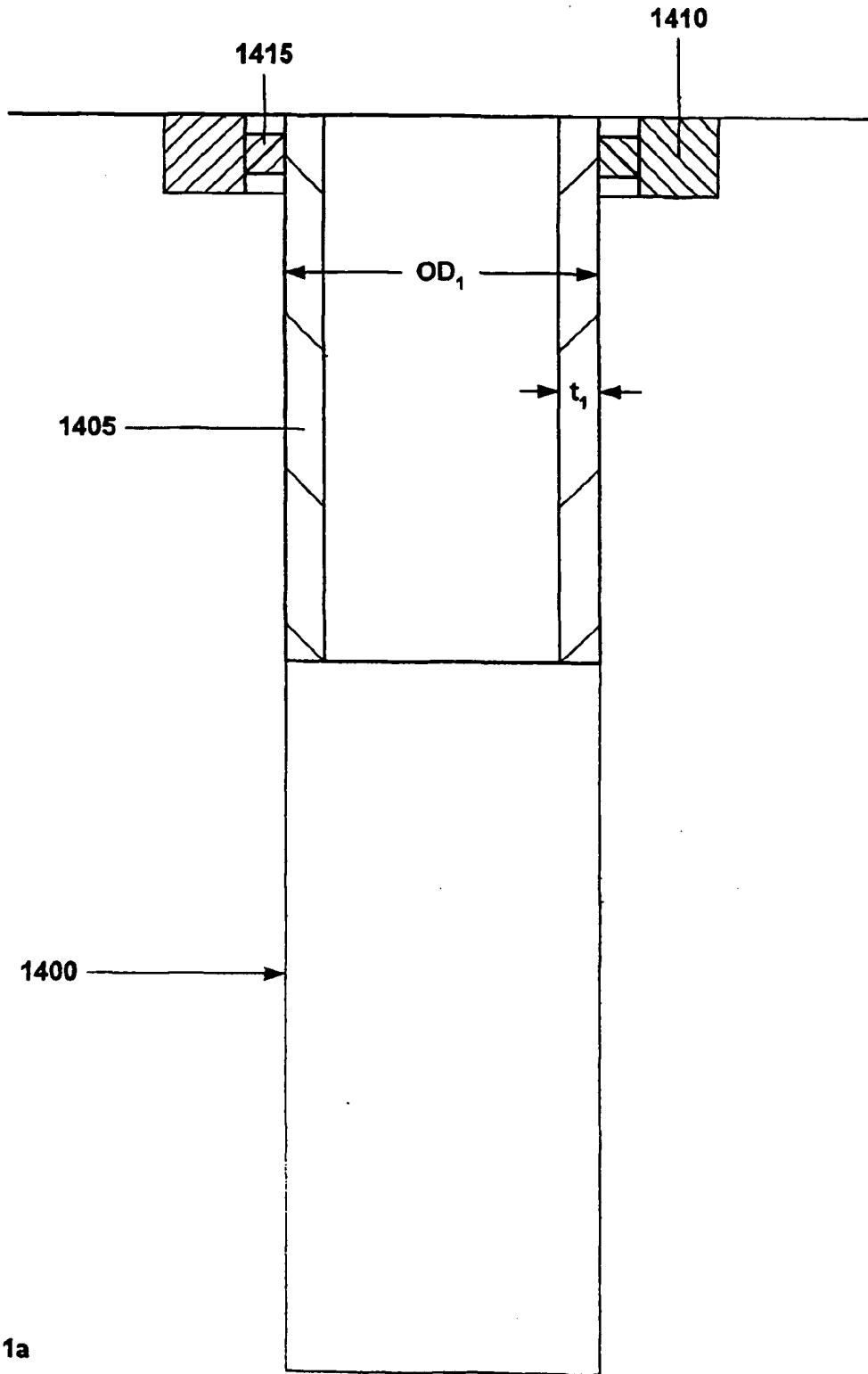

Fig. 11a

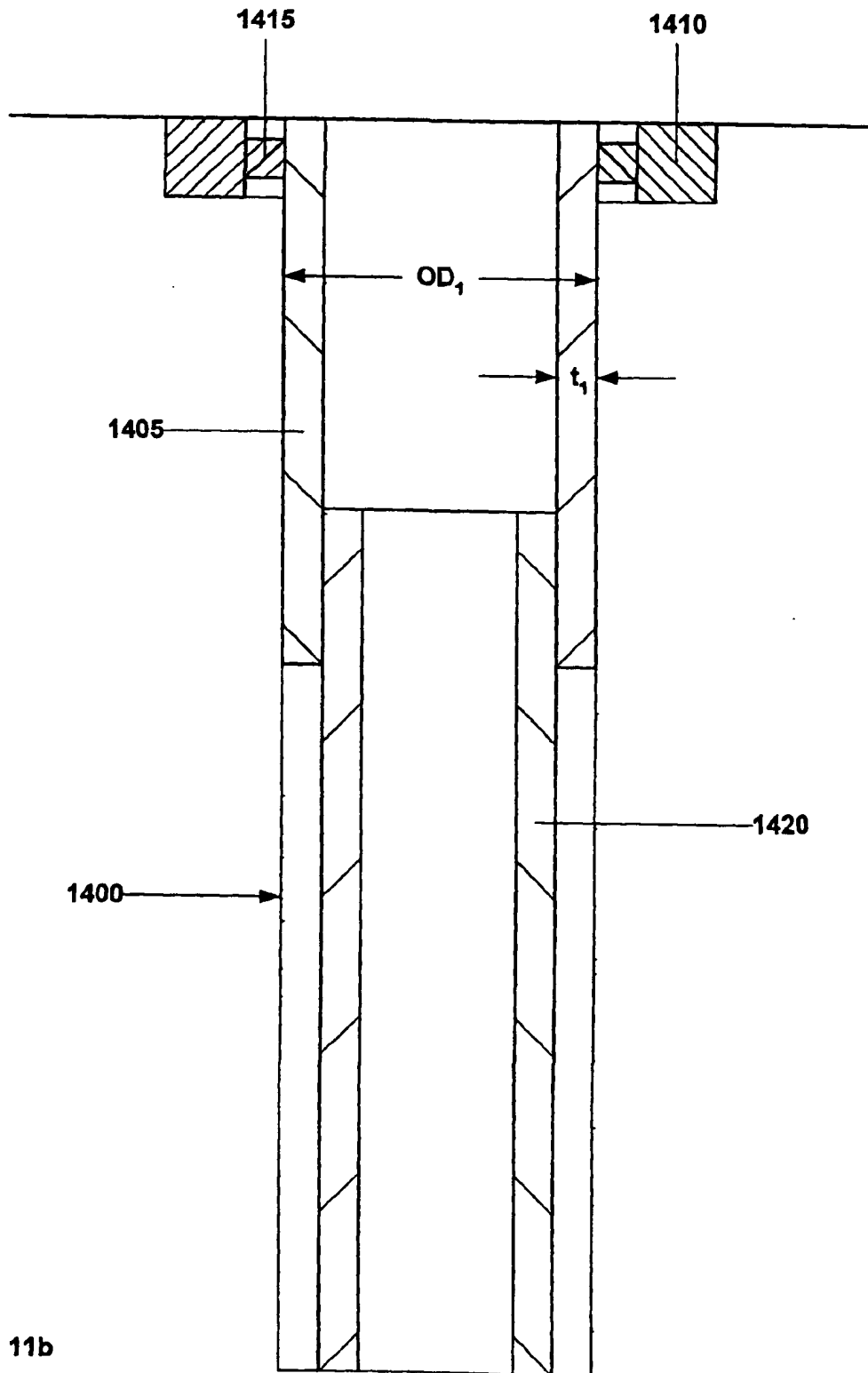

Fig. 11b

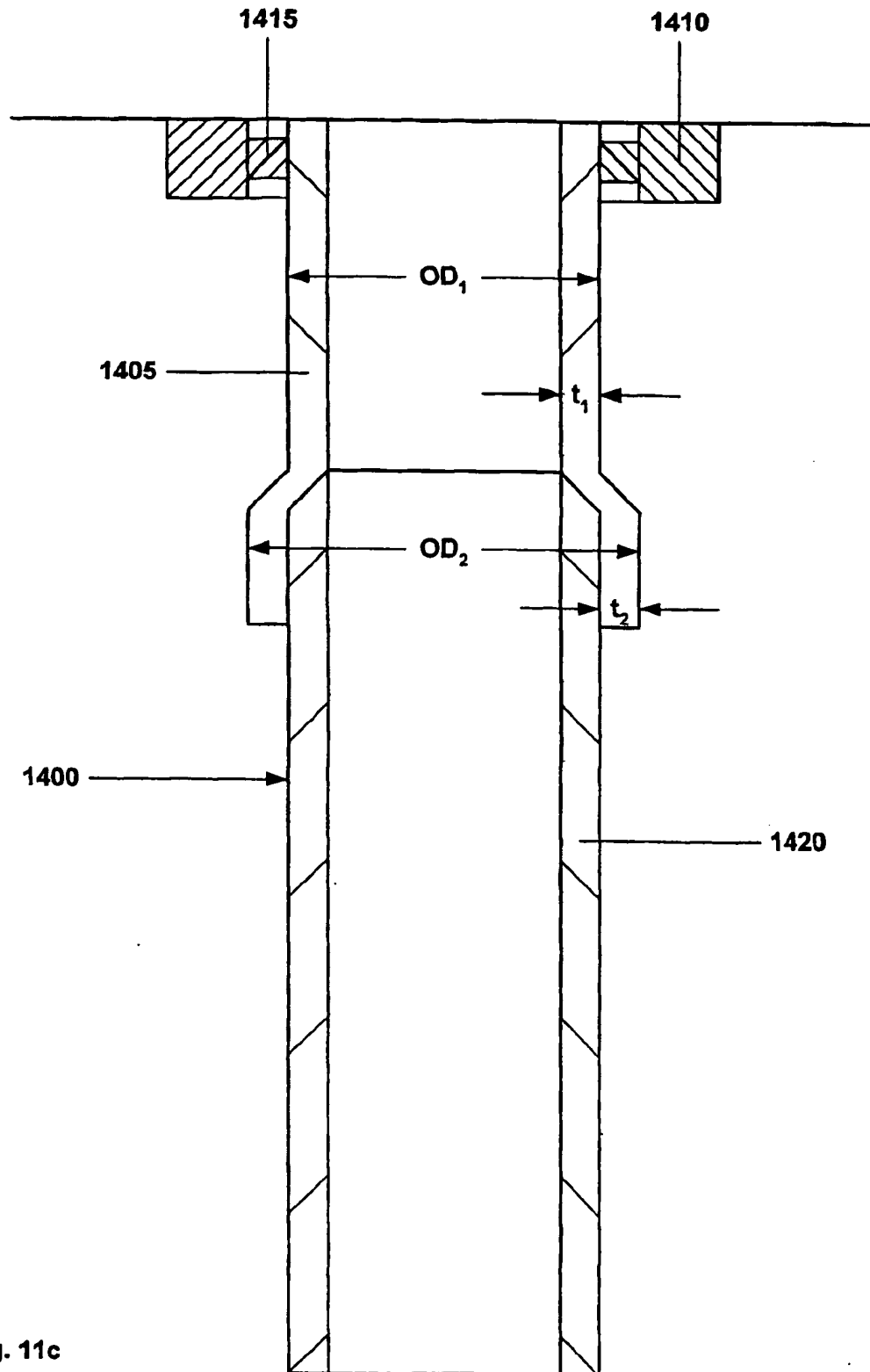

Fig. 11c